

## **APRILIA WOULD LIKE TO THANK YOU**

for choosing one of its products. We have compiled this booklet to provide a comprehensive overview of your vehicle's quality features. Please read it carefully before riding the vehicle for the first time. It contains information, tips and precautions for using your vehicle. It also describes features, details and devices to assure you that you have made the right choice. We believe that if you follow our suggestions, you will soon get to know your new vehicle well and that it will continue to give you satisfactory service for many years to come. This booklet is an integral part of the vehicle and must be handed over to the new owner in the event of sale.

# **CAPONORD 1200**



The instructions given in this manual are intended to provide a clear, simple guide to using your vehicle; it also describes routine maintenance procedures and regular checks that should be carried out on the vehicle at an **Aprilia Dealer or Authorised Workshop**. The booklet also contains instructions for simple repairs. Any operations not specifically described in this booklet require the use of special tools and/or particular technical knowledge: for these operations, please take your vehicle to an **Aprilia Dealer or Authorised Workshop**.



### **Personal safety**

Failure to completely observe these instructions will result in serious risk of personal injury.



### **Safeguarding the environment**

Sections marked with this symbol indicate the correct use of the vehicle to prevent damaging the environment.



### **Vehicle intactness**

The incomplete or non-observance of these regulations leads to the risk of serious damage to the vehicle and sometimes even the invalidity of the guarantee

*The symbols illustrated above are very important. They are used to highlight parts of the booklet that should be read with particular care. The different symbols are used to make each topic in the manual simple and quick to locate. Before starting the engine, read this booklet carefully, particularly the "SAFE RIDING" section. Your safety as well as other's does not only depend on the quickness of your reflexes and agility, but also on how well you know your vehicle, the state of maintenance of the vehicle itself and your knowledge of the rules for SAFE RIDING. For your safety, get to know your vehicle well so as to safely ride and master it given any riding condition. **IMPORTANT** This booklet is an integral part of the vehicle, and must be handed to the new owner in the event of sale.*



# INDEX

<b>GENERAL RULES</b> .....	7	System ABS.....	62
Foreword.....	8	System ATC (Aprilia Traction Control).....	65
Motorcycle care.....	8	ADD system (Aprilia Dynamic Damping).....	69
Carbon monoxide.....	11	Immobilizer system operation.....	71
Fuel.....	12	Glove/tool kit compartment.....	72
Hot components.....	12	USB Port.....	72
The braking.....	13	Identification.....	74
Warning lights.....	13	Adjusting the windscreen.....	75
Coolant.....	14	Provision for the installation of accessories.....	75
Used engine oil and gearbox oil.....	15	<b>USE</b> .....	83
Brake and clutch fluid.....	15	Checks.....	84
Battery hydrogen gas and electrolyte.....	16	Refuelling.....	87
Stand.....	16	Rear shock absorbers adjustment.....	88
Reporting of defects that affect safety.....	17	Rear shock absorbers setting.....	90
<b>VEHICLE</b> .....	19	Front fork adjustment.....	92
Arrangement of the main components.....	21	Justering af greb til forbremse.....	95
Dashboard.....	29	Clutch lever adjustment.....	95
Instrument panel.....	30	Running in.....	96
Light unit.....	32	Starting up the engine.....	97
Digital lcd display.....	33	Ride by wire.....	100
Mapping selection.....	41	Moving off / riding.....	101
Control buttons.....	43	Parking.....	105
Ignition switch.....	53	Catalytic silencer.....	106
Locking the steering wheel.....	53	Stand.....	108
Horn button.....	54	Suggestion to prevent theft.....	109
Switch direction indicators.....	55	Safe driving.....	110
High/low beam selector.....	56	Basic safety rules.....	112
Passing button.....	56	<b>MAINTENANCE</b> .....	117
Supplementary light switch.....	57	Engine oil level check.....	118
Heated handgrip control.....	57	Engine oil top-up.....	119
Start-up button.....	58	Engine oil change.....	120
Engine stop switch.....	59	Engine oil filter replacement.....	120
Button Cruise Control.....	59	Tyres.....	121

Spark plug dismantlement.....	122
Removing the air filter.....	122
Cooling fluid level.....	123
Checking the brake oil level.....	125
Braking system fluid top up.....	126
Checking clutch fluid.....	126
Topping up clutch fluid.....	126
Battery removal.....	127
Checking the electrolyte level.....	128
Charging the battery.....	128
Long periods of inactivity.....	129
Fuses.....	130
Lamps.....	134
Low/High beam lamp replacement.....	135
Position light replacement.....	136
Front light group.....	136
Headlight adjustment.....	137
Front direction indicators.....	139
Additional light.....	139
Rear optical unit.....	140
Rear turn indicators.....	140
Number plate light.....	141
Rear-view mirrors.....	141
Front and rear disc brake.....	143
Periods of inactivity.....	144
Cleaning the vehicle.....	145
Transport.....	150
Transmission chain.....	150
Chain backlash check.....	151
Chain backlash adjustment.....	151
Checking wear of chain, front and rear sprockets.....	152
Chain lubrication and cleaning.....	152
<b>TECHNICAL DATA.....</b>	<b>155</b>
Kit equipment.....	166
<b>PROGRAMMED MAINTENANCE.....</b>	<b>167</b>
Scheduled maintenance table.....	168
Table of recommended products.....	171

# CAPONORD 1200

**aprilia**



**Chap. 01**  
**General rules**

## Foreword

### NOTE

**CARRY OUT MAINTENANCE OPERATIONS AT HALF THE INTERVALS SPECIFIED IF THE VEHICLE IS USED IN PARTICULAR RAINY OR DUSTY CONDITIONS, OFF ROAD OR FOR TRACK USE.**

## Motorcycle care

Aprilia recommends using quality products to clean the vehicle. The use of unsuitable products can damage vehicle components. For cleaning do not use solvents such as "nitro thinner", "cold cleaning agents", fuels or similar, or cleaning products that contain alcohol.

### WASHING THE MOTORCYCLE

Aprilia recommends softening with plenty of water and then carefully removing the insects and more stubborn stains before washing the vehicle.

To prevent stains, do not wash the motorcycle immediately after exposure to sunlight, and do not wash it in the sun.

If the vehicle is used during the winter months, be sure to frequently wash the motorcycle. To remove anti-icing salt sprayed on roads in the winter, wash the motorcycle with cold water immediately after use.

### CAUTION

**AFTER CLEANING YOUR MOTORCYCLE, THE EFFICIENCY OF THE BRAKING SYSTEM MAY BE TEMPORARILY AFFECTED DUE TO THE PRESENCE OF WATER ON THE FRICTION SURFACES. CONSIDER AN INCREASE IN BRAKING SPACE, OPERATE THE BRAKES REPEATEDLY TO RESTORE NORMAL CONDITIONS. CARRY OUT THE PRE-RIDE CHECKS BEFORE USE.**





**USE OF HOT WATER INTENSIFIES THE EFFECT OF THE SALT. USE ONLY PLENTY OF COLD WATER TO WASH AND REMOVE ANTI-ICING SALT**



**USE OF HIGH PRESSURE WASHING SYSTEMS (OR STEAM CLEANERS) CAN DAMAGE THE SEALS, OIL SEALS, BRAKING SYSTEM, ELECTRICAL SYSTEM AND THE SADDLE. DO NOT USE STEAM OR HIGH PRESSURE CLEANING SYSTEMS. DO NOT USE STEAM OR HIGH PRESSURE CLEANING SYSTEMS.**

## **CLEANING OF SENSITIVE PARTS**

### **BODYWORK**

To keep the motorcycle bright, wash it regularly, especially if used in areas with high levels of pollution or mud. Aggressive stains from tree resins, gasoline, oil, brake fluid or bird excrement in general

must be removed immediately, otherwise permanent stains on the paint can appear. After washing it is easy to identify marks and residual stains, remove them from the body using a soft cloth and brand-name, non-abrasive polish, and protect with a protective wax for cars. Periodic care, a thorough cleaning and regular protective wax for the bodywork preserves the aesthetic quality of the motorcycle over the long term.

### **PLASTIC COMPONENTS**



**IF THE PLASTIC COMPONENTS ARE CLEANED USING AGGRESSIVE AGENTS, THE SURFACE MAY BE DAMAGED. DO NOT USE CLEANING PRODUCTS CONTAINING ALCOHOL, SOLVENTS OR THAT ARE ABRASIVE FOR THE CLEANING**

**OF PLASTIC PARTS. ROTARY BRUSHES OR SPONGES WITH HARD SURFACES CAN MAKE SCRATCHES**

#### **CHROME PARTS AND POLISHED METAL**



**TREAT THE PARTS MADE OF CHROME, ALUMINIUM OR POLISHED STEEL IN A SPECIAL MANNER. WASH THEM WITH PLENTY OF WATER AND CAR SHAMPOO, POLISH AND REGULARLY BRIGHTEN THEM WITH POLISH PASTE, PROTECT THEM WITH WAXES OR SUITABLE ACID-FREE PRODUCTS (E.G. VASELINE)**

#### **RADIATOR**



**IF USING THE MOTORCYCLE IN THE WINTER ON ROADS WITH DE-ICING SALT, REGULARLY WASH THE RADIATOR TO PREVENT AESTHETIC DAMAGE AND THE ENGINE FROM OVERHEATING. WASH USING PLENTY OF WATER. FOR EXAMPLE USE GARDEN RUBBER WITH WATER AT LOW PRESSURE.**

#### **RUBBER PARTS**

Clean the rubber parts using water and mild shampoo (brand-name, suitable for car bodies)



**THE USE OF SILICONE SPRAY TO CLEAN THE RUBBER SEALS MAY CAUSE DAMAGE. DO NOT USE OTHER PRODUCTS CONTAINING SILICON FOR CLEANING THE MOTORCYCLE**

### **Carbon monoxide**

If you need to keep the engine running in order to perform a procedure, please ensure that you do so in an open or very well ventilated area. Never let the engine run in an enclosed area. If you do work in an enclosed area, make sure to use a smoke-extraction system.

#### **CAUTION**



**EXHAUST EMISSIONS CONTAIN CARBON MONOXIDE, A POISONOUS GAS WHICH CAN CAUSE LOSS OF CONSCIOUSNESS AND EVEN DEATH.**

#### **CAUTION**



**CARBON MONOXIDE IS ODOURLESS AND COLOURLESS, THEREFORE IT CANNOT BE DETECTED BY SMELL, SIGHT OR OTHER SENSES. DO NOT BREATHE IN EXHAUST FUMES UNDER ANY CIRCUMSTANCES.**

## Fuel

### CAUTION



**THE FUEL USED TO POWER INTERNAL COMBUSTION ENGINES IS HIGHLY FLAMMABLE AND MAY BE EXPLOSIVE UNDER CERTAIN CONDITIONS. IT IS THEREFORE RECOMMENDED TO CARRY OUT REFUELLING AND MAINTENANCE PROCEDURES IN A VENTILATED AREA WITH THE ENGINE SWITCHED OFF. DO NOT SMOKE DURING REFUELLING AND NEAR FUEL VAPOURS, AVOIDING ANY CONTACT WITH NAKED FLAMES, SPARKS OR OTHER SOURCES WHICH MAY CAUSE THEM TO IGNITE OR EXPLODE.**

**DO NOT DISPERSE FUEL IN THE ENVIRONMENT.**

**KEEP OUT OF THE REACH OF CHILDREN**



**IF THE VEHICLE FALLS OR IS ON A STEEP INCLINE FUEL CAN LEAK.**

## Hot components

The engine and the exhaust system components get very hot and remain in this condition for a certain time interval after the engine has been switched off. Before handling these components, make sure that you are wearing insulating gloves or wait until the engine and the exhaust system have cooled down.

## The braking

### CAUTION

**STOP THE VEHICLE MAINLY USING THE FRONT BRAKE. THE REAR BRAKE MUST ONLY BE USED TO BALANCE THE BRAKING EFFECT, AND ONLY TOGETHER WITH THE FRONT BRAKE.**

## Warning lights



**THERE ARE SEVERAL WARNING LIGHTS ON THE INSTRUMENT PANEL OF THE MOTORCYCLE. FOR INFORMATION ON HOW THEY WORK, READ THIS USE AND MAINTENANCE MANUAL.**



**IF THE WARNING LIGHT BLINKS AND THE ENGINE OIL ICON IS ON WHILE THE ENGINE IS WORKING PROPERLY, THIS MEANS THAT THE OIL PRESSURE IN THE CIRCUIT IS NOT ENOUGH. IN THIS CASE THE ENGINE MUST BE IMMEDIATELY SHUT OFF IN ORDER TO AVOID ANY POSSIBLE DAMAGE.**



**CARRY OUT ENGINE OIL LEVEL CHECK. IF THE OIL PRESSURE LEVEL REMAINS LOW ALTHOUGH THE PROCEDURE DESCRIBED ABOVE HAS BEEN PROPERLY CARRIED OUT, CONTACT AN OFFICIAL Aprilia DEALER TO HAVE THE CIRCUIT CHECKED.**



**IF THE WARNING LIGHT TURNS PERMANENTLY ON AND THE HELMET ICONS ON THE DISPLAY ARE ALL SIMULTANEOUSLY BLINKING WHILE THE ENGINE**

**IS WORKING PROPERLY, IT MEANS THAT THE VEHICLE CONTROL UNIT (VCU) HAS DETECTED A FAULT. IN MANY CASES THE ENGINE WILL CONTINUE TO OPERATE REGULARLY, WITH LIMITED PERFORMANCE OF THE SHOCK ABSORBERS; FOR SAFETY REASONS, SLOW DOWN; IMMEDIATELY CONTACT AN Official Aprilia Dealer.**

## Coolant

The coolant contains ethylene glycol which, under certain conditions, can become flammable. When ethylene glycol burns, it produces an invisible flame which can nevertheless cause burns.

### CAUTION



**TAKE CARE NOT TO POUR COOLANT ONTO HOT ENGINE OR EXHAUST SYSTEM COMPONENTS; THE FLUID MAY CATCH FIRE AND BURN WITH INVISIBLE FLAMES. WHEN CARRYING OUT MAINTENANCE OPERATIONS, IT IS ADVISABLE TO WEAR LATEX GLOVES. EVEN THOUGH IT IS TOXIC, COOLANT HAS A SWEET FLAVOUR WHICH MAKES IT VERY ATTRACTIVE TO ANIMALS. NEVER LEAVE THE COOLANT IN OPEN CONTAINERS IN AREAS ACCESSIBLE TO ANIMALS AS THEY MAY DRINK IT.**

**KEEP OUT OF THE REACH OF CHILDREN**

**DO NOT REMOVE THE RADIATOR CAP WHEN THE ENGINE IS STILL HOT. THE COOLANT IS UNDER PRESSURE AND MAY CAUSE BURNS.**

## Used engine oil and gearbox oil

### CAUTION



**IT IS ADVISABLE TO WEAR PROTECTIVE IMPERMEABLE GLOVES WHEN SERVICING THE VEHICLE.**

**THE ENGINE OR GEARBOX OIL MAY CAUSE SERIOUS INJURIES TO THE SKIN IF HANDLED FOR PROLONGED PERIODS OF TIME AND ON A REGULAR BASIS.**

**WASH YOUR HANDS CAREFULLY AFTER HANDLING OIL.**

**HAND THE OIL OVER TO OR HAVE IT COLLECTED BY THE NEAREST USED OIL RECYCLING COMPANY OR THE SUPPLIER.**

**DO NOT DISPOSE OF OIL IN THE ENVIRONMENT**

**KEEP OUT OF THE REACH OF CHILDREN**

## Brake and clutch fluid

### Brake and clutch fluid



**BRAKE AND CLUTCH FLUIDS CAN DAMAGE THE PLASTIC OR RUBBER PAINTED SURFACES. WHEN SERVICING THE BRAKING SYSTEM OR THE CLUTCH SYSTEM, PROTECT THESE COMPONENTS WITH A CLEAN CLOTH. ALWAYS WEAR PROTECTIVE GOGGLES WHEN SERVICING THESE SYSTEMS. BRAKE AND CLUTCH FLUIDS ARE EXTREMELY HARMFUL FOR YOUR EYES. IN THE EVENT OF ACCIDENTAL CONTACT WITH THE EYES, RINSE THEM IMMEDIATELY WITH ABUNDANT COLD, CLEAN WATER AND SEEK MEDICAL ADVICE.**

**KEEP OUT OF THE REACH OF CHILDREN**

## Battery hydrogen gas and electrolyte

### CAUTION



THE BATTERY ELECTROLYTE IS TOXIC, CORROSIVE AND AS IT CONTAINS SULPHURIC ACID, IT CAN CAUSE BURNS WHEN IN CONTACT WITH THE SKIN. WHEN HANDLING BATTERY ELECTROLYTE, WEAR TIGHT-FITTING GLOVES AND PROTECTIVE APPAREL. IN THE EVENT OF SKIN CONTACT WITH THE ELECTROLYTIC FLUID, RINSE WELL WITH PLENTY OF CLEAN WATER. IT IS PARTICULARLY IMPORTANT TO PROTECT YOUR EYES BECAUSE EVEN TINY AMOUNTS OF BATTERY ACID MAY CAUSE BLINDNESS. IF THE FLUID GETS IN CONTACT WITH YOUR EYES, WASH WITH ABUNDANT WATER FOR FIFTEEN MINUTES AND CONSULT AN EYE SPECIALIST IMMEDIATELY. THE BATTERY RELEASES EXPLOSIVE GASES; KEEP IT AWAY FROM FLAMES, SPARKS, CIGARETTES OR ANY OTHER HEAT SOURCES. ENSURE ADEQUATE VENTILATION WHEN SERVICING OR RECHARGING THE BATTERY.

KEEP OUT OF THE REACH OF CHILDREN

BATTERY LIQUID IS CORROSIVE. DO NOT POUR IT OR SPILL IT, PARTICULARLY ON PLASTIC COMPONENTS. ENSURE THAT THE ELECTROLYTIC ACID IS COMPATIBLE WITH THE BATTERY TO BE ACTIVATED.

### Stand



BEFORE SETTING OFF, MAKE SURE THE CENTRE STAND (IF INSTALLED) AND THE SIDE ONE ARE COMPLETELY RETRACTED TO THEIR POSITION.

DO NOT REST THE RIDER OR PASSENGER WEIGHT ON THE SIDE STAND.



## Reporting of defects that affect safety

Unless otherwise specified in this Use and Maintenance Booklet, do not remove any mechanical or electrical component.

### CAUTION

**SOME CONNECTORS IN THE VEHICLE MAY BE ACCIDENTALLY SWAPPED AND MAY COMPROMISE NORMAL VEHICLE OPERATION IF INCORRECTLY INSTALLED.**

## 1 General rules

# CAPONORD 1200

**aprilia**



**Chap. 02  
Vehicle**

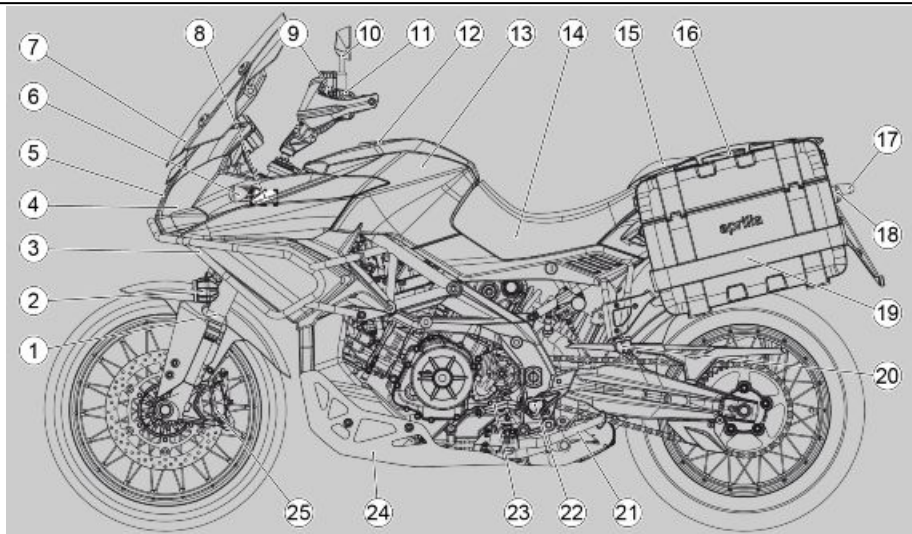

02\_01

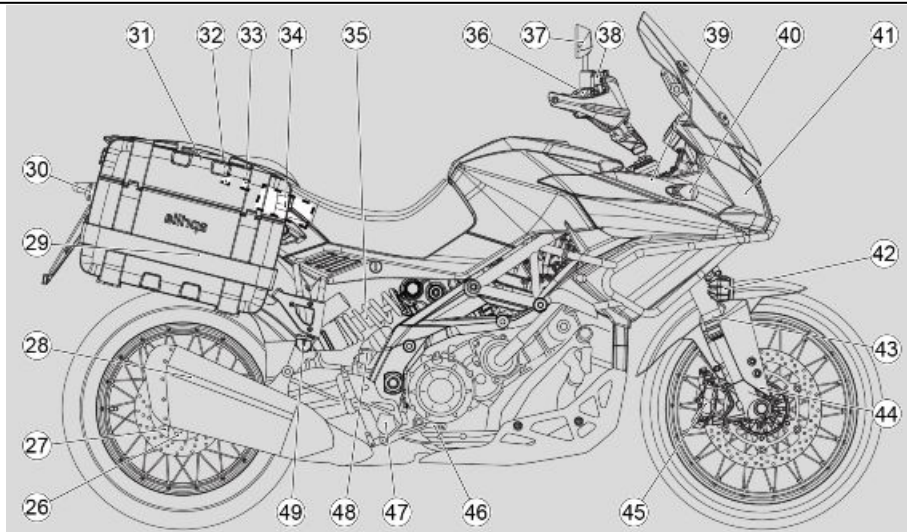

02\_02

## Arrangement of the main components (02\_02)

### Key (Caponord 1200 Rally):

1. Front left fork
2. Additional left headlamp
3. Front bumper
4. Left headlamp
5. Central headlamp
6. Front left turn indicator
7. Windshield
8. Auxiliary fuses box
9. Clutch fluid reservoir
10. Left rear-view mirror
11. Left light switch

12. Fuel tank cap
13. Fuel tank
14. Rider saddle
15. Passenger saddle
16. Left passenger grab handle
17. Licence plate light
18. Rear left turn indicator
19. Left side suitcase
20. Left hand passenger footrest
21. Side stand
22. Left rider footrest
23. Gear lever
24. Oil sump guard
25. Front left brake calliper
26. Rear speed sensor
27. Rear brake calliper
28. Exhaust muffler
29. Right side suitcase
30. Rear right turn indicator
31. Right passenger grab handle
32. USB port
33. Main fuses
34. Battery
35. Adjustable rear shock absorber
36. Right hand light switch
37. Right rear-view mirror
38. Front brake system fluid reservoir
39. Cooling liquid reservoir
40. Front right turn indicator
41. Front right headlamp
42. Additional right headlamp
43. Front right fork
44. Front speed sensor
45. Front right brake calliper
46. Rear brake lever
47. Right hand rider footrest
48. Rear brake system fluid reservoir
49. Right hand passenger footrest

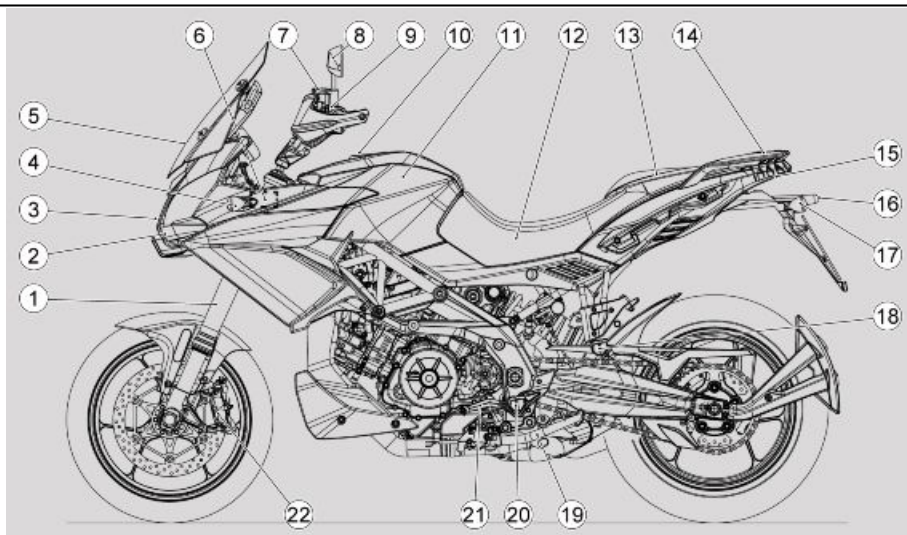

02\_03

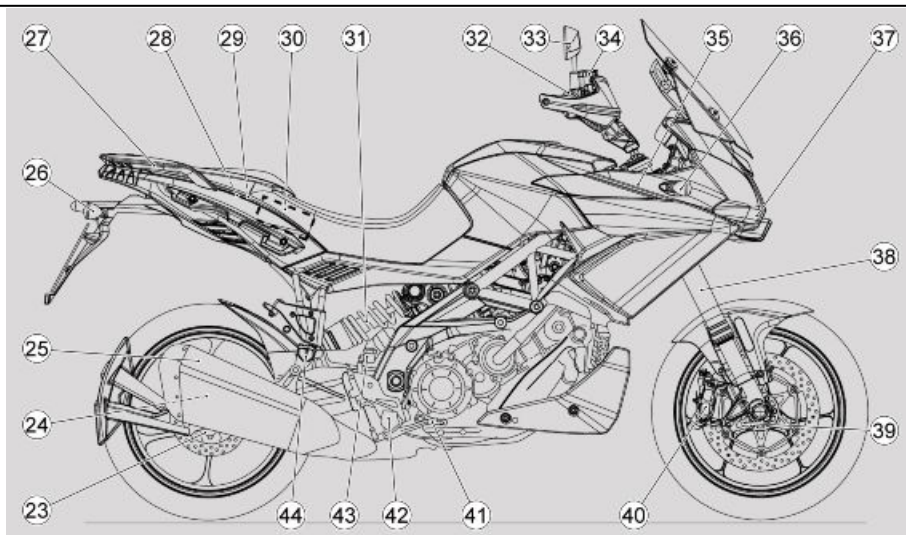

02\_04

**Legend (Caponord 1200):**

1. Front left fork
2. Left headlamp
3. Central headlamp
4. Front left turn indicator
5. Windshield
6. Auxiliary fuses box
7. Clutch fluid reservoir
8. Left rear-view mirror
9. Left light switch
10. Fuel tank cap
11. Fuel tank
12. Rider saddle
13. Passenger saddle



14. Left passenger grab handle
15. Taillight
16. Licence plate light
17. Rear left turn indicator
18. Left hand passenger footrest
19. Side stand
20. Left rider footrest
21. Gear lever
22. Front left brake calliper
23. Rear speed sensor
24. Rear brake calliper
25. Exhaust muffler
26. Rear right turn indicator
27. Right passenger grab handle
28. USB port
29. Main fuses
30. Battery
31. Adjustable rear shock absorber
32. Right hand light switch
33. Right rear-view mirror
34. Front brake system fluid reservoir
35. Cooling liquid reservoir
36. Front right turn indicator
37. Front right headlamp
38. Front right fork
39. Front speed sensor
40. Front right brake calliper
41. Rear brake lever
42. Right hand rider footrest
43. Rear brake system fluid reservoir
44. Right hand passenger footrest

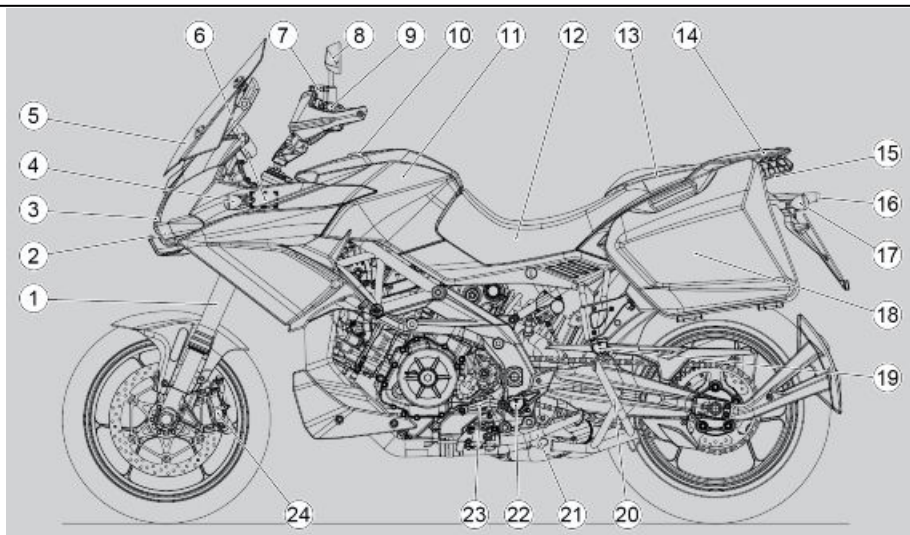

02\_05

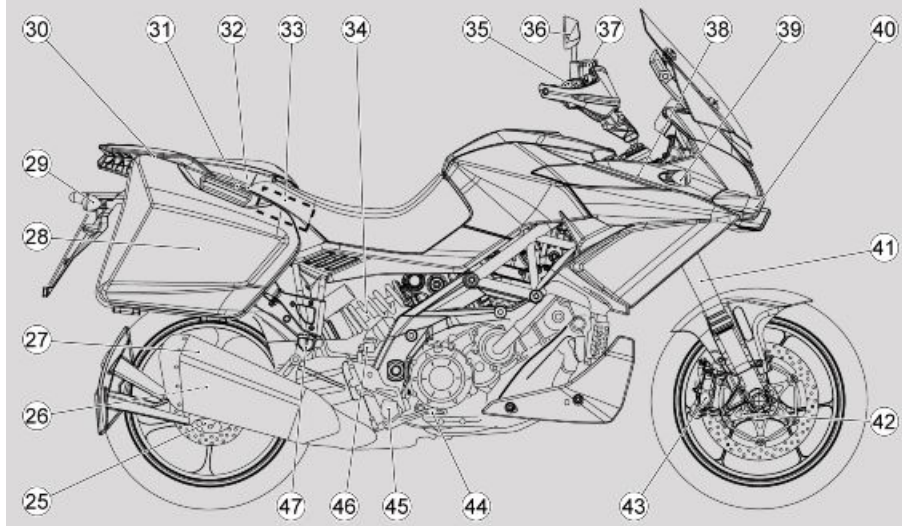

02\_06

**Legend (Caponord 1200 Travel Pack):**

1. Front left fork
2. Left headlamp
3. Central headlamp
4. Front left turn indicator
5. Windshield
6. Auxiliary fuses box
7. Clutch fluid reservoir
8. Left rear-view mirror
9. Left light switch
10. Fuel tank cap
11. Fuel tank
12. Rider saddle
13. Passenger saddle

14. Left passenger grab handle
15. Taillight
16. Licence plate light
17. Rear left turn indicator
18. Left side saddle pannier
19. Left hand passenger footrest
20. Centre stand
21. Side stand
22. Left rider footrest
23. Gear lever
24. Front left brake calliper
25. Rear speed sensor
26. Rear brake calliper
27. Exhaust muffler
28. Right saddle bag
29. Rear right turn indicator
30. Right passenger grab handle
31. USB port
32. Main fuses
33. Battery
34. Adjustable rear shock absorber
35. Right hand light switch
36. Right rear-view mirror
37. Front brake system fluid reservoir
38. Cooling liquid reservoir
39. Front right turn indicator
40. Front right headlamp
41. Front right fork
42. Front speed sensor
43. Front right brake calliper
44. Rear brake lever
45. Right hand rider footrest
46. Rear brake system fluid reservoir
47. Right hand passenger footrest

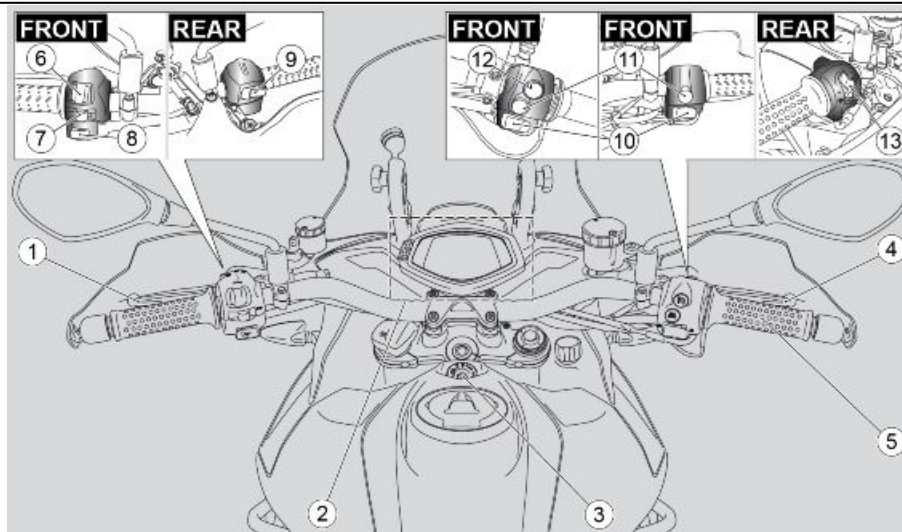

02\_07

## Dashboard (02\_07)

### Instrument panel / controls location key

1. Clutch control lever
2. Instrument panel
3. Ignition switch /steering lock
4. Front brake lever
5. Throttle grip
6. MODE Control
7. Warning lights Control
8. Horn button
9. Light switch
10. Starter button and engine stop switch (On/Off)
11. Heated handgrip button (if applicable)

- 12. Cruise control button (if applicable)
- 13. Supplementary headlamps switch

### Instrument panel (02\_08, 02\_09)

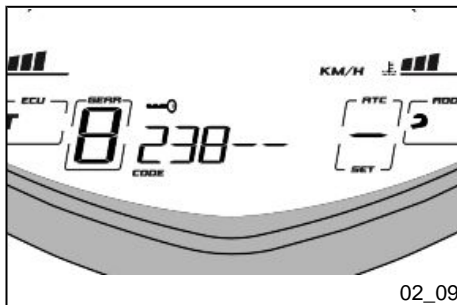

02\_08

**key:**

1. Multifunctional digital display
2. Warning lights
3. Control buttons

The instrument panel has an immobilizer system which prevents start-up in case the system does not identify a key which has been stored before.

The vehicle is supplied with two keys already programmed. The instrument panel saves a maximum of four keys: contact an Official **Aprilia** Dealer to enable these keys or to disable a key that has been lost. When the vehicle is delivered and approximately ten seconds after the key is set to ON (the CODE icon will always be blinking), the instrument panel requests a personal five-digit code to be entered. This request is no longer displayed once the personal code is entered. For code entering procedure, see the CONTROL BUTTONS section

**It is important to remember the personal code because:**

- **the vehicle can be started if the immobilizer system is faulty**
- **the instrument panel need not be replaced should the ignition switch be changed**
- **new keys can be programmed**

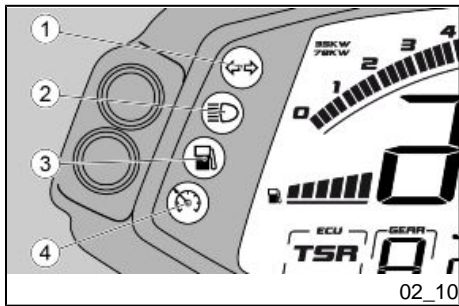

## Light unit (02\_10, 02\_11, 02\_12)

key:

1. Turn indicator warning light (green)
2. High beam warning light (blue)
3. Low fuel warning light (orange)
4. Cruise control warning light (green)

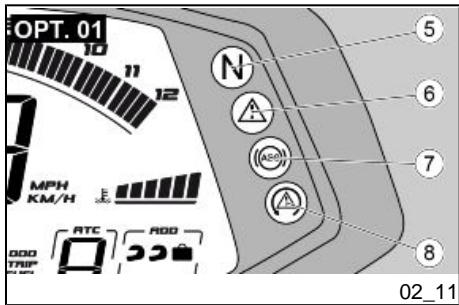

5. Gear in neutral warning light (green)
6. General warning light (red)
7. ABS (Anti-lock Braking System) warning light (orange)
8. MI warning light (Malfunction indicator) (orange)

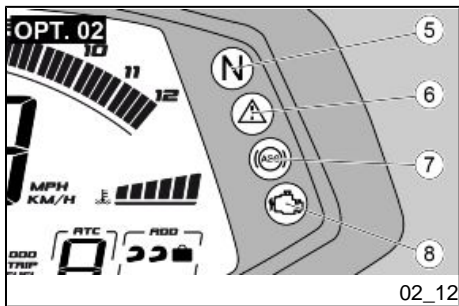



## Digital Lcd display (02\_13, 02\_14, 02\_15, 02\_16, 02\_17, 02\_18, 02\_19, 02\_20, 02\_21, 02\_22, 02\_23, 02\_24, 02\_25, 02\_26, 02\_27, 02\_28, 02\_29, 02\_30, 02\_31)

The following indicators will light up for a couple of seconds on the instrument panel when the ignition key is set to "ON":

- all the warning lights;
- the backlighting turns off after the key is set to ON.

After two seconds, all instruments immediately show the current value of the measurements read.

### NOTE

**THE FUEL GAUGE LIGHT REQUIRES SOME TIME TO STABILIZE.**

### NOTE

**EVERY TIME THE SELECTOR IS HELD DOWN TO THE RIGHT OR LEFT THE RIDER CAN GO FROM TRIP JOURNAL 1 TO TRIP JOURNAL 2.**



The standard settings that can be viewed on the display are:

- 1) Any indication relative to power limitation in the ECU;
- 2) Engine rpm;
- 3) Speed (speedometer) (can be displayed in Kph or in Mph);

- 4) Fuel level;
- 5) Selected engine mapping;
- 6) Gear selected;
- 7) Immobilizer alarm;
- 8) Engine oil pressure alarm;
- 9) ABS icon (viewable in setting phase);
- 10) Any service deadline;
- 11) Engine alarm (EFI Electronic Fuel Injection)
- 12) Heated handgrip operating intensity level (if applicable)
- 13) Trip computer or any alarms, specifically:
  - total odometer
  - Trip odometer
  - Reserve travel
  - Travelling time
  - Average travelling speed
  - Maximum saved speed
  - Clock
- 14) ATC (Aprilia Traction Control)
- 15) ADD (Aprilia Dynamic Damping)
- 16) Water temperature

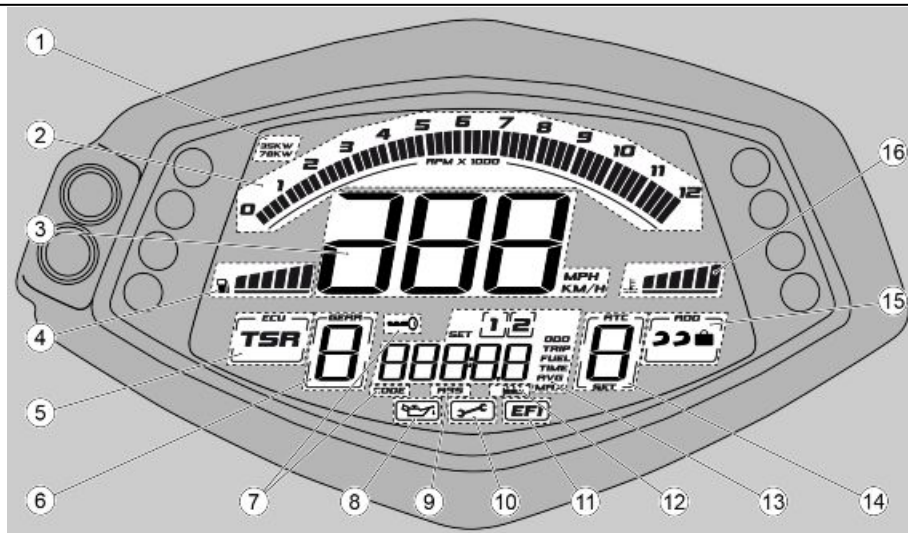

02\_14

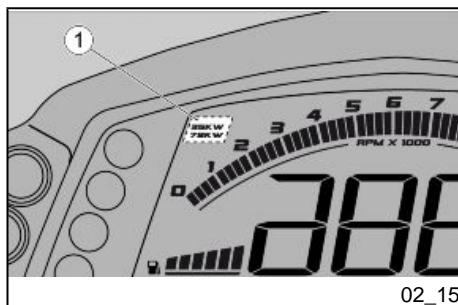

02\_15

### MAPPING IN VCU

In the upper left of the digital display, the indication of the engine power map (1) currently in use is visible, only if there is a map with limited power different from the standard one.

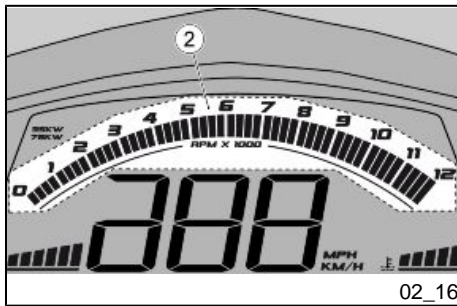

### ENGINE RPM

In the middle of the digital display, the indication of the engine rpm (2) is visible, with a maximum threshold of 12,000 rpm (12 - rpm x 1000)



### MAXIMUM SPEED

In the middle of the digital display, the indication of the maximum speed (3) is visible in kmph or mph, depending on your Country.

### NOTE

**YOU CAN HAVE THE INDICATED VALUE MODIFIED BY CONTACTING AN Official Aprilia Dealer**

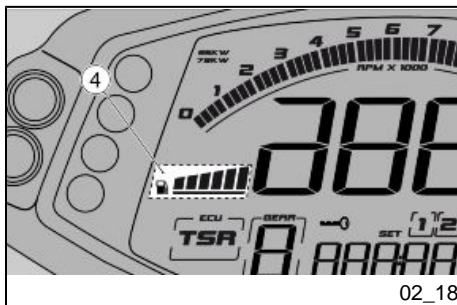

### FUEL LEVEL

On the digital display, center-left, the fuel level in the tank can be viewed through a series of bars (4).

When the fuel level drops far enough for all bars to go off on the digital display, the fuel reserve warning light will turn on

### CAUTION

**THE DISTANCE TRAVELLED CORRESPONDING TO THE LAST FUEL INDICATOR BAR IS ABOUT THREE TIMES HIGHER THAN THE ONE OF THE OTHER BARS**

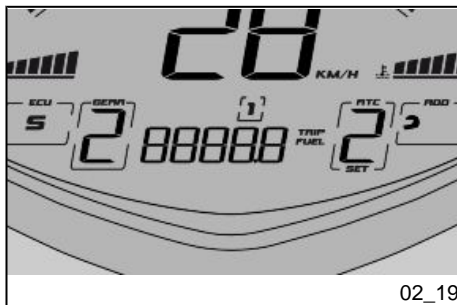

02\_19

Two kilometres (1.24 mi) after the low fuel warning light turns on, the kilometres travelled with low fuel are shown on the digital display.

#### NOTE

**TO ENSURE A CORRECT READING, THE FUEL LOW INDICATION MAY BE DELAYED BY UP TO 60 SECONDS.**

When the reserve fuel warning light is active, pressing a MODE control button will cause it to disappear and reappear 60 seconds later.

#### NOTE

**THE FUEL LEVEL INDICATION MAY CHANGE DEPENDING ON THE INCLINATION OF THE MOTORCYCLE WHEN IT IS ON THE SIDE STAND AS OPPOSED TO WHEN IT IS IN MOTION.**

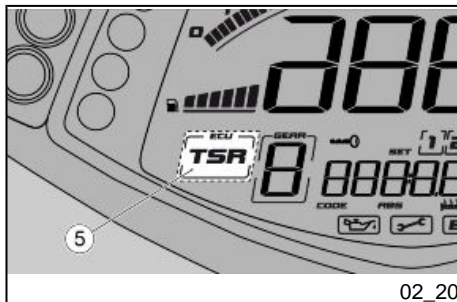

02\_20

#### ENGINE MAP

In the left part of the digital display, the selected engine map (5) currently in use is visible (TOURING / SPORT / RAIN).

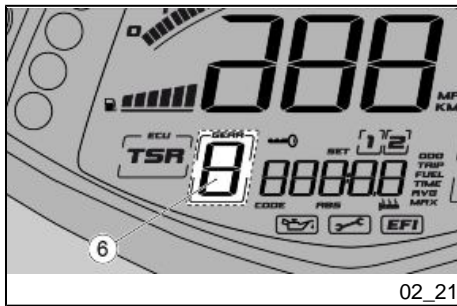

### GEAR ENGAGED

In the lower left of the digital display, the indication of the selected gear (6) currently in use can be viewed.

When the motorcycle is running idle, the symbol "0" will be displayed

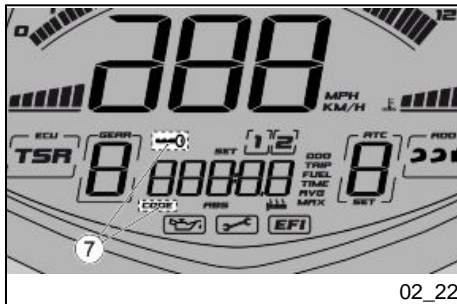

### ENGINE ALARM (EFI Electronic Fuel Injection)

If there is a system failure, the key symbol will be viewable in the middle of the display, or the request to enter the user code (7)

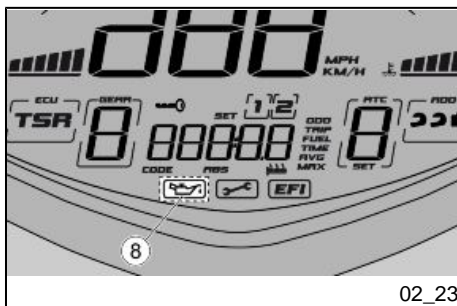

### ENGINE OIL PRESSURE ALARM

If there is a failure of the motorcycle's lubrication system, the icon of the oil glass (8) will turn on in the middle of the digital display, to indicate the malfunction.

#### NOTE

**WHEN THE ICON IS PERMANENTLY LIT, IT MEANS THERE IS AN ALARM DUE TO THE OIL PRESSURE SENSOR**

**WHEN THE ICON IS BLINKING, IT MEANS THERE IS AN ALARM DUE TO AB-NORMAL OIL PRESSURE IN THE ENGINE**

## ABS

In the middle of the digital display there is an ABS icon (9) that will only be viewable when setting system parameters.

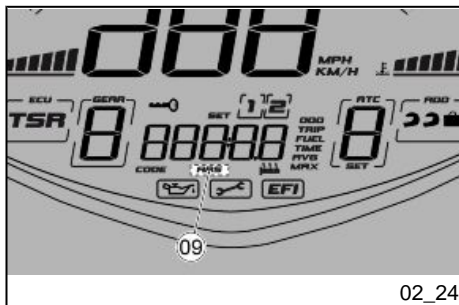

02\_24

## SERVICE THRESHOLD

When the thresholds of the maintenance intervals have been exceeded an adjustable spanner icon will appear (10) in the middle of the digital display.

This indicator may be reset once the scheduled service has been completed by an **authorised Aprilia Dealer or Service Centre**.

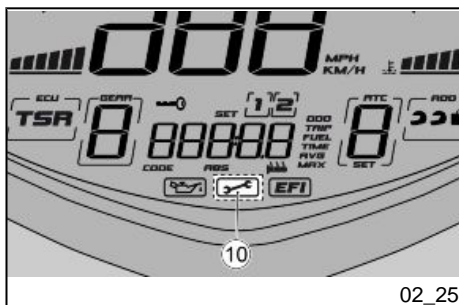

02\_25

## HEATED HANDGRIPS

(if applicable)

If the heated handgrips are activated, the corresponding symbol (11) can be viewed in the middle of the digital display.

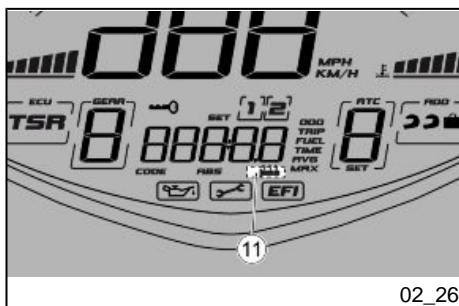

02\_26

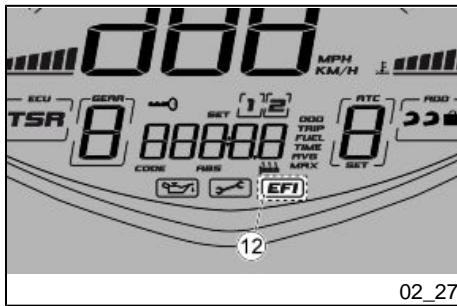

### EFI

The wording EFI (Electronic Fuel Injection) (12) will appear in the middle of the digital display, should there be problem with the fuel injection.

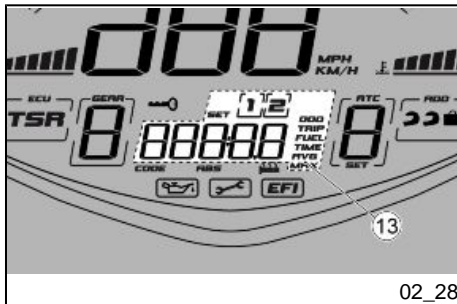

### TRAVEL COMPUTER

The travel computer (13) appears in the middle of the digital display to provide specific information on the distance travelled, speed and travelling time.

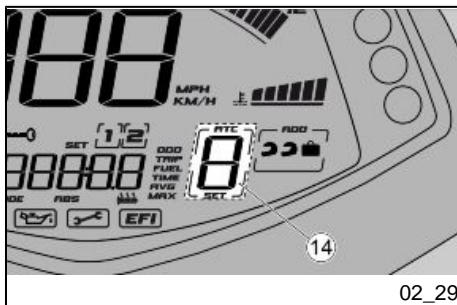

### ATC (Aprilia Traction Control)

The Traction Control operating level (14) currently in use appears on the right side of the digital display.



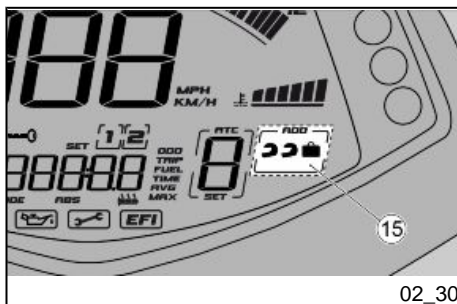

02\_30

### ADD (Aprilia Dynamic Damping)

The level of the rear shock absorber (15) preload appears in the right side of the digital display, to show the selection made by the rider by way of certain symbols (helmets and suitcases).

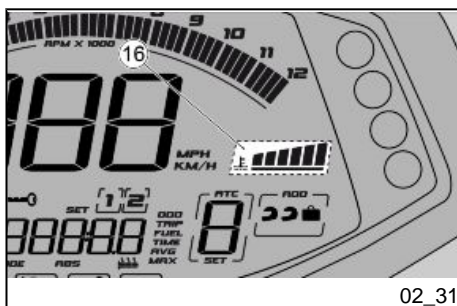

02\_31

### WATER TEMPERATURE

The running temperature of the cooling system (16) can be viewed in the right side of the digital display, indicated by a series of bars.

If the temperature rises to a level that is too high, the general warning light will also turn on.

### Mapping selection (02\_32)

The engine control unit foresees 3 different "mapping" variants to manage the electronic throttle grip, which are displayed as seen in the upper left section of the instrument panel digital display:

- **T** is the **TOURING** mapping
- **S** is the **SPORT** mapping
- **R** is the **RAIN** mapping

The **TOURING** mode has been thought for smooth tourist riding.

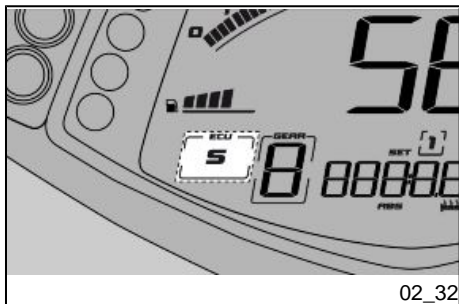

02\_32

In the **SPORT** mode you get more acceleration; this variant has been thought for a sporting use of the vehicle.

#### CAUTION

**ONLY EXPERT RIDERS, RIDING ON ROADS WITH GOOD GRIP ARE ADVISED TO USE THIS MODE. IT IS NOT RECOMMENDED FOR WET SURFACES AND/OR ROADS WITH LOW GRIP.**

The **RAIN** mode has been thought for riding on wet surfaces or roads with low grip. The system reduces the maximum torque supplied by the engine and smoothly delivers it so as to prevent loss of grip. In this mode, the vehicle performance is limited, and therefore, the maximum speed cannot be reached.

**EVEN IN THIS MODE, ALWAYS USE PARTICULAR CAUTION WHEN RIDING IN POOR GRIP CONDITIONS.**

Push the starter button to go through the different mappings. Five seconds after the engine is started, this button can be used as a mapping selection button.

#### CAUTION

**MAP SELECTION IS ONLY PERMITTED WITH THE ENGINE RUNNING AND THE THROTTLE RELEASED. MAP SELECTION IS ALSO POSSIBLE WITH THE MOTORCYCLE IN MOTION, PROVIDED THAT THE THROTTLE GRIP IS RELEASED.**

To change mappings, proceed as follows:

- press the button once and the symbol for the mapping currently being used is shown blinking on the display
- press the button a second time, and within 1.5 seconds from the first pressing, the next mapping is selected and highlighted with the blinking frame on the display. If more than 1.5 seconds elapse and the button is not pressed again (the next mapping is otherwise selected) and without twisting the throttle control, the new mapping is highlighted with the frame lit steady on the display. This means that the new mapping is applied for all practical purposes.

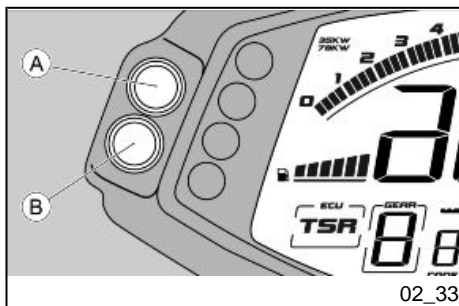

## Control buttons (02\_33, 02\_34, 02\_35, 02\_36, 02\_37, 02\_38, 02\_39, 02\_40, 02\_41, 02\_42, 02\_43, 02\_44, 02\_45, 02\_46, 02\_47, 02\_48, 02\_49)

### CONTROL BUTTONS ON INSTRUMENT PANEL

The instrument panel has two control buttons "A" and "B" to allow access to certain functions and settings of the digital display, among which:

- ATC;
- ADD;
- ABS;
- Calibration;
- Instrument panel backlighting;
- Service functions.

By briefly pressing button "B", it is possible to view the ATC, ADD, ABS functions in cycle.

### ATC (Aprilia Traction Control)

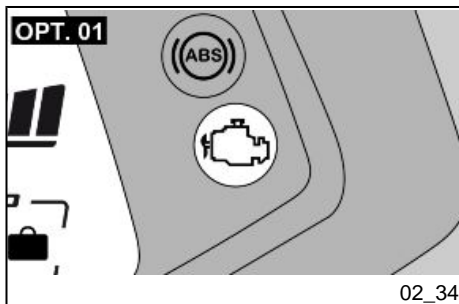

### OPTION 01

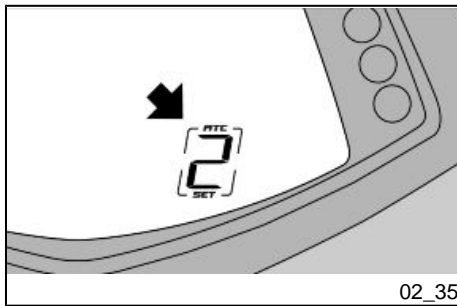

02\_35

To modify the value of the displayed function, briefly press button "A", which will increase the intensity of the system's intervention from level 1 (minimum) to level 3 (maximum).

If you continue to press the button, the intensity will progressively be lowered to the minimum level.

#### CAUTION

**TO BECOME FAMILIAR WITH THE ATC SYSTEM, IT IS ADVISABLE TO SET THE VALUE "3" TO THEN IDENTIFY THE PREFERRED SETTING FOR THE RIDING STYLE AND FOR THE ROAD AND ENVIRONMENTAL CONDITIONS WHICH MAY APPEAR.**

**LEVEL "1" IS RECOMMENDED FOR USE BY EXPERT RIDERS IN IDEAL ROAD SURFACE CONDITIONS.**

**LEVEL "2" IS AN INTERMEDIATE SETTING BETWEEN LEVEL "1" AND LEVEL "3".**

To deactivate the system hold button A pressed (from level 1) until the value displayed is "0" flashing.

To exit the ATC function, hold button "B" pressed for a few seconds or move off from a standstill.

#### NOTE

**WHEN THE BATTERY IS FIRST CONNECTED, THE TRACTION CONTROL LEVEL WILL BE ALWAYS ZERO**

#### NOTE

**IF THE MOTORCYCLE IGNITION SWITCH IS TURNED OFF, AT THE NEXT KEY-ON, THE ATC SYSTEM MAINTAINS THE PREVIOUSLY SELECTED SETTINGS, IF THE KEY IS KEPT TURNED OFF FOR AT LEAST 30 sec FROM THE LAST ATC SETTING.**

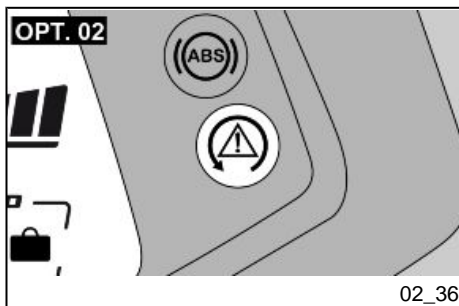

## OPTION 02

To modify the value of the displayed function, briefly press button "A", which will increase the intensity of the system's intervention from level 1 (minimum) to level 3 (maximum).

If you continue to press the button, the intensity will progressively be lowered to the minimum level.

ATC warning light will blink.

### CAUTION

**TO BECOME FAMILIAR WITH THE ATC SYSTEM, IT IS ADVISABLE TO SET THE VALUE "3" TO THEN IDENTIFY THE PREFERRED SETTING FOR THE RIDING STYLE AND FOR THE ROAD AND ENVIRONMENTAL CONDITIONS WHICH MAY APPEAR.**

**LEVEL "1" IS RECOMMENDED FOR USE BY EXPERT RIDERS IN IDEAL ROAD SURFACE CONDITIONS.**

**LEVEL "2" IS AN INTERMEDIATE SETTING BETWEEN LEVEL "1" AND LEVEL "3".**

To deactivate the system hold button A pressed (from level 1) until the value displayed is "-".

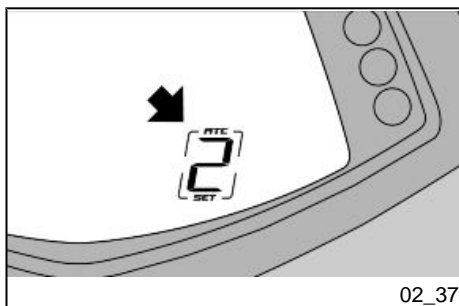

ATC warning light will remain on with a steady light.

To exit the ATC function, hold button "B" pressed for a few seconds or move off from a standstill.

#### NOTE

**WHEN THE BATTERY IS FIRST CONNECTED, THE ATC WARNING LIGHT REMAINS ON WITH A STEADY LIGHT (NOT ACTIVE SYSTEM)**

#### NOTE

**WHEN THE VEHICLE PANEL IS OFF AND WHEN TURNING IT ON THE NEXT TIME, THE ATC SYSTEM KEEPS THE SETTINGS SELECTED PREVIOUSLY.**

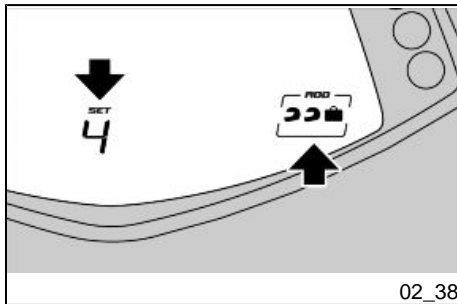

#### ADD (Aprilia Dynamic Damping)

To modify the value of the preload function displayed, briefly press button "A", which will modify the type of intervention according to the driver's needs.

The system is identified by a series of symbols that correspond to a certain type of specific setting:

- The helmet corresponds to the preload setting with only the driver on board
- The helmet and suitcase corresponds to the preload setting with the driver and luggage
- Two helmets correspond to the preload setting with driver and passenger
- Two helmets and a suitcase correspond to the preload setting with driver, passenger and luggage
- Two helmets and a suitcase blinking in sequence correspond to the preload setting in automatic mode

#### NOTE

**WITH THE MOTORCYCLE'S INSTRUMENT PANEL SWITCHED OFF, AT THE NEXT IGNITION OF THE SYSTEM THE ADD KEEPS THE SETTINGS CHOSEN PREVIOUSLY.**

## ABS

To activate or deactivate the system, briefly press button "A", which will either activate or deactivate the system in cycles.

If the system is activated, the ABS warning light will blink

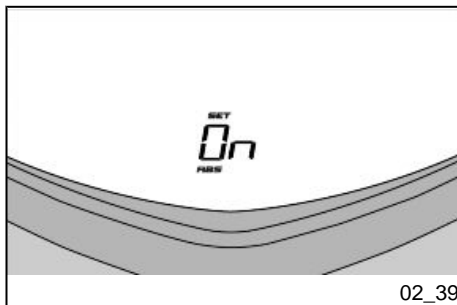

If the system is deactivated, the ABS warning light will stay permanently on.

In both cases, to confirm the selected mode, hold button "B" pressed for a few seconds.

The function will automatically appear after 5 seconds, if the selection is not made promptly, or when the motorcycle is running.

### NOTE

**AT KEY ON, IF THE SYSTEM IS FUNCTIONING CORRECTLY, THE ABS INDICATOR LIGHT WILL BLINK (ONCE A VEHICLE SPEED OF 5 Km/h - 3.1 mph IS EXCEEDED, THE SYSTEM WILL ONLY BE ACTIVE IF THE WARNING LIGHT GOES OFF)**

### NOTE

**WHEN THE BIKE'S PANEL IS OFF AND WHEN TURNING IT ON THE NEXT TIME THE ABS SYSTEM IS STILL ACTIVE, REGARDLESS OF WHAT WAS SET PREVIOUSLY.**

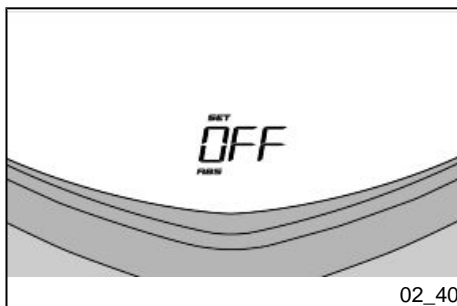

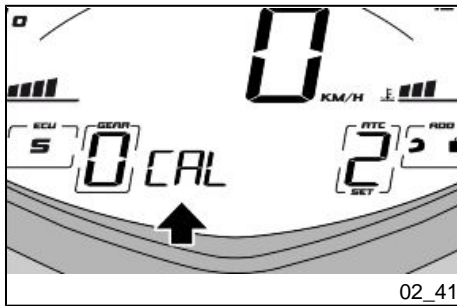

## CALIBRATION

To access the CALIBRATION function, simultaneously hold buttons "A" and "B" pressed for a few seconds.

When the function is activated (with vehicle at a standstill), the following wording will appear on the screen page of the display:

CAL

The high beam light will start to blink fast.

To calibrate the ATC (Aprilia Traction Control) system, ride for approximately 10 seconds in a straight line on a flat section of road in second gear and at a speed of 30 +/- 2 Km/h (18.64 +/- 1.24 mph), until the message CAL is no longer shown on the display and the light turns off.

### NOTE

**ONCE THE WORD CALIBRATION DISAPPEARS FROM THE DISPLAY, TO COMPLETE THE CALIBRATION PROCEDURE, STOP THE VEHICLE AND SHUT OFF THE PANEL FOR AT LEAST 30 SECONDS.**

**THIS ALLOWS THE CALIBRATION TO BE STORED IN THE MEMORY.**

### NOTE

**CARRY OUT THE CALIBRATION EACH TIME TYRES TYPE OR DRIVE GEAR-MODE IS CHANGED.**

### NOTE

**TURN THE IGNITION SWITCH OFF TO ABORT THE CALIBRATION PROCEDURE.**

**DURING CALIBRATION, ATC IS AUTOMATICALLY DEACTIVATED (IF PREVIOUSLY ACTIVATED).**



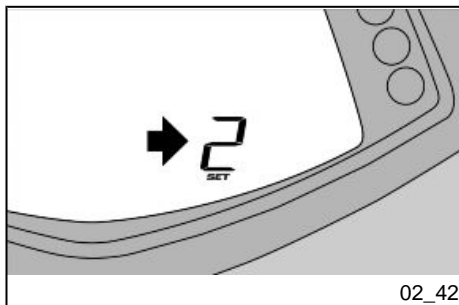

02\_42

## BACKLIGHTING

To modify the intensity of the digital display's backlighting, hold button "B" pressed for a few seconds, to access the adjustments screen page.

Whenever button "A" is briefly pressed, backlighting intensity (indicated by a number on the digital display) increases up to a maximum of 5 levels.

The function is cyclical, which means that once the maximum value is reached, if button "A" is pressed again, the backlighting will restart from the minimum value

To quit the function, hold button "B" pressed for a few seconds; the function will automatically quit after 5 seconds.

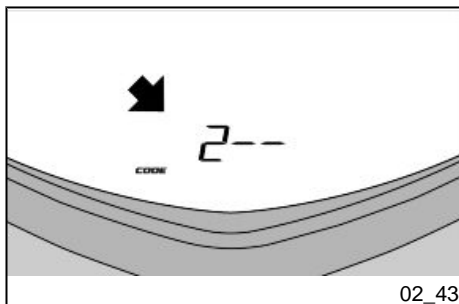

02\_43

## SERVICE FUNCTIONS

With control buttons "A" and "B", it is possible to enter or modify the code of the immobilizer key.

### Entering a new code

During the motorcycle's first ignition, the message CODE will appear on the digital display, blinking slowly. This message warns the rider that the key safety code must be entered.

To access the function, hold button "A" pressed for a few seconds

Enter code "222", briefly pressing button "B"

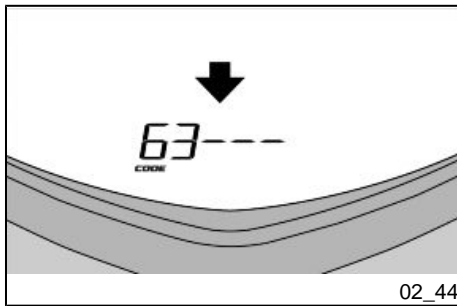

Enter the new 5-digit personal code, briefly pressing button "B"

After entering the code it remains displayed until the instrument panel is switched off.

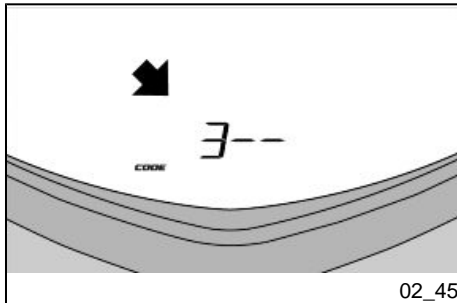

### Modify code

It is possible to reset the existing code.

To access the function, hold button "A" pressed for a few seconds.

Enter code "384", briefly pressing button "B"

Enter the old code

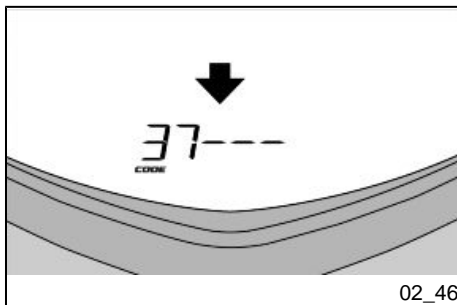

At this point it is possible to insert the new code.

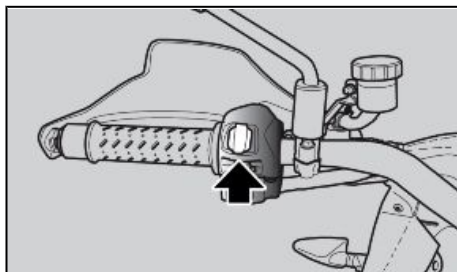

02\_47

## MODE SWITCH

By using the MODE switch, it is possible to view, reset or modify the information in the trip journal, depending on the indicated value.



02\_48

## Trip journal 1 and 2

Two trip journals are available (\*).

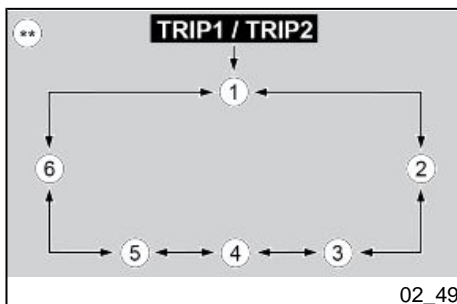

02\_49

Press and hold down the MODE control to the left to select the TRIP JOURNAL 1; icon "1" on the DIGITAL DISPLAY turns on.

Press and hold down the MODE control to the right to select the TRIP JOURNAL 2; icon "2" on the DIGITAL DISPLAY turns on.

In both journals, each time the MODE control is pressed briefly to the right or left, the following information is displayed in sequence (\*\*):

ODOMETER (1)

TRIP ODOMETER (2)

TRAVELLING TIME (3)

AVERAGE SPEED (4)

MAXIMUM SPEED (5)

CLOCK (6)

With the following options: PARTIAL ODOMETER, TRAVELLING TIME, MAXIMUM SPEED; holding the central button down resets all the saved values in the active TRIP JOURNAL.

### **CLOCK**

To adjust the clock, the TRIP1 or TRIP2 menu must be scrolled until the function is reached.

When pressing the MODE selector for a few seconds, you enter this mode, the minutes of the clock disappear and only the hours remain. Each time the MODE selector is pressed to the right, the hour value increases; likewise, each time the MODE selector is pressed to the left, the hour value decreases. Press the MODE selector central part to store the set value and to shift to minute adjustment.

The minute indicator is no longer displayed when this function is activated; only the hour indicator is shown. Each time the MODE selector is pressed to the right, the minute value increases; likewise, each time the MODE selector is pressed to the left the minute value decreases.

Press the MODE selector central part to store the set value and to exit the clock adjustment function.

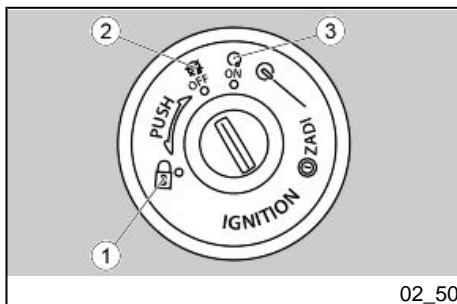

## Ignition switch (02\_50)

The ignition switch (1) is located at the front of the fuel reservoir.

The vehicle is supplied with two keys (one is the spare key).

The lights go off when the ignition switch is set to «OFF».

### NOTE

**THE KEY ACTIVATES THE IGNITION SWITCH AND OPERATES THE STEERING LOCK.**

### NOTE

**THE LIGHTS COME ON AUTOMATICALLY AFTER THE ENGINE STARTS.**

**LOCK (1):** The steering is locked. It is not possible to start the engine or switch on the lights. The key can be extracted

**OFF (2):** The engine and lights cannot be set to work. The key can be extracted.

**ON (3):** the engine may be started. The key cannot be extracted.

## Locking the steering wheel

### To lock the steering:

- Turn the handlebar completely to the left.
- Turn the key to «OFF».
- Push in the key and turn it anticlockwise (to the left), steer the handlebar slowly until the key is set to «LOCK».
- Remove the key.

**CAUTION**



**TO AVOID LOSING CONTROL OF THE VEHICLE, NEVER TURN THE KEY TO "LOCK" WHILE RIDING.**

**Horn button (02\_51)**

**NOTE**

**ELECTRICAL COMPONENTS FUNCTION ONLY WHEN THE IGNITION KEY IS SET TO "ON"**

Press it to activate the horn.

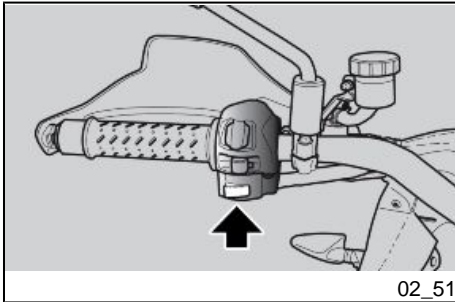

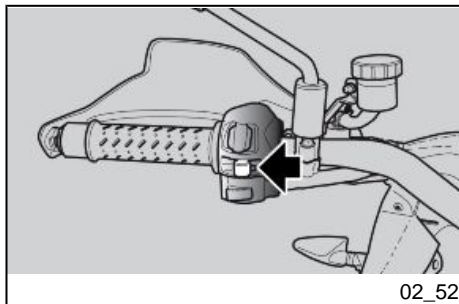

## Switch direction indicators (02\_52)

Move the switch to the left, to indicate a left turn; move the switch to the right to indicate a right turn. Pressing the switch deactivates the turn indicator.

### CAUTION

**IF THE WARNING LIGHT WITH ARROWS FLASHES QUICKLY, IT MEANS THAT ONE OR BOTH TURN SIGNALS LIGHT BULBS ARE BURNT OUT.**

The turn indicators have a self-cancelling function that implements the following logic.

With the vehicle at a standstill (speed = zero), the turn indicators continue flashing indefinitely.

With the vehicle in motion, the turn signals self-cancel when one of the two following conditions is met:

- After a time (t) = 40 sec.
- After riding 500 m (0.31 mi).

If the vehicle speed reaches zero during this period, the time and distance counts are reset and start again from zero when the vehicle starts moving once again.

Switching on the opposite side turn indicators without pressing the switch in the intermediate reset position causes both the time and distance counters to reset and recommence from zero.

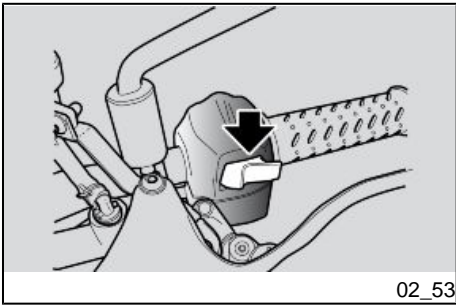

### High/low beam selector (02\_53)

The high beams are switched on with the light switches located at the centre.

Press the light switch to the right, to turn on the high beam light;

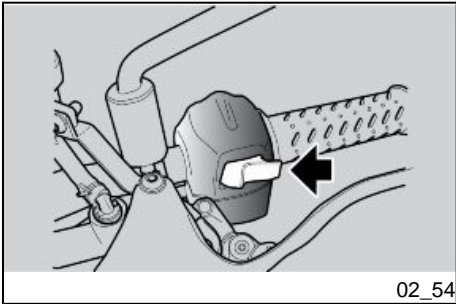

### Passing button (02\_54)

Uses the high beam flash in case of danger or emergency.

Releasing the switch deactivates the high beam flash.



## Supplementary light switch (02\_55)

To use the supplementary headlamps:

- Set the ignition to "ON".
- Turn on the additional headlights using the switch found on the front part of the right switch.



02\_55

## Heated handgrip control (02\_56, 02\_57)

(IF AVAILABLE)

Activation, deactivation and heat level of the handgrips take place by short pressing the control.

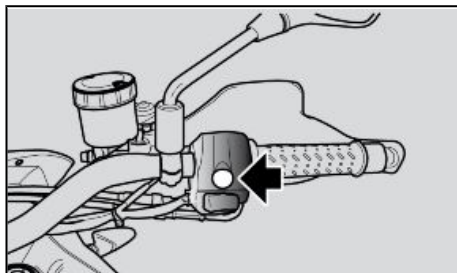

02\_56

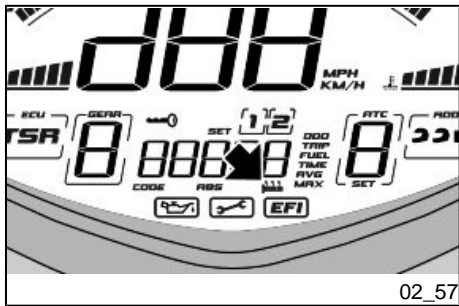

There are 3 heat intensity levels which are activated cyclically from level 1 (minimum) to level 3 (maximum) each time the control is pressed. After level 3, pressing the control again deactivates the function.

If the key is switched to the OFF position, upon restarting the function will be deactivated.

#### NOTE

**THE HANDGRIPS ARE HEATED ONLY WHEN THE ENGINE IS RUNNING AND ABOVE 2000 RPM, REGARDLESS OF THE SELECTED INTENSITY LEVEL.**

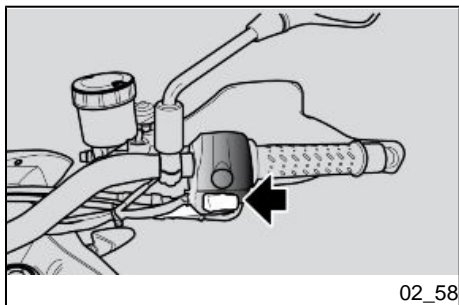

#### Start-up button (02\_58)

Press the button and the starter motor spins the engine.

#### CAUTION

**FIVE SECONDS AFTER THE ENGINE IS STARTED, THIS BUTTON CAN BE USED AS "MAPPING SELECTION" BUTTON.**

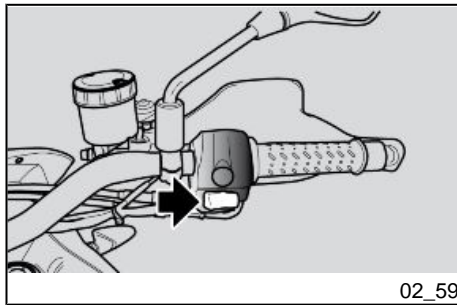

## Engine stop switch (02\_59)

It acts as an engine cut-off or emergency stop switch.

Press this switch to stop the engine.

## Button Cruise Control (02\_60, 02\_61)

(IF APPLICABLE)

- Cruise control is an electronic system which keeps the vehicle at the speed selected by the rider
- To activate the function (switching from OFF to ON), press and hold the Cruise Control button for approximately 2 seconds
- If the system is on this will be indicated by a flashing warning light on the instrument panel

The system can be used in a specific speed range, only for third through sixth gear, even while decelerating with the throttle grip closed, as defined in the table below:

## SYSTEM ACTIVATION SPEED

SPEED	3rd	4th	5th	6th
MIN Speed	50 km/h (31.07 mph)	60 km/h (37.28 mph)	65 km/h (40.39 mph)	70 km/h (43.50 mph)
MAX Speed	100 km/h (62.14 MPH)	120 km/h (74.56 MPH)	160 km/h (99.42 MPH)	180 km/h (111.85 MPH)

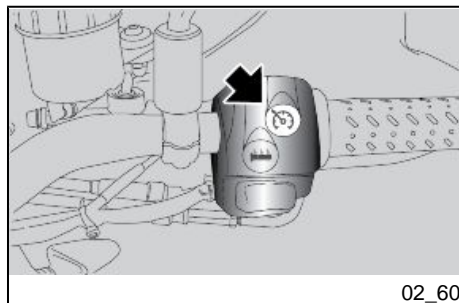

02\_60

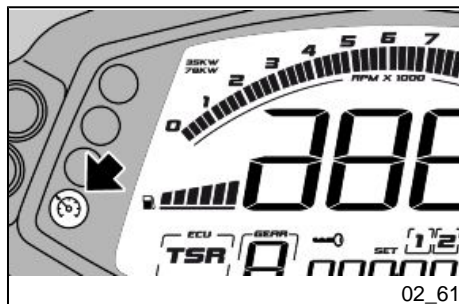

02\_61

Once the desired speed is reached, the system may be activated (SET state) by pressing the cruise control button briefly, provided that the following conditions are met:

- The engaged gear must not be lower than third and cannot be neutral:
- The brakes must not be applied:
- The clutch lever must not be in use:

The instrument panel indicator lamp lights continuously to indicate that the system is active.

The throttle grip may now be released, and the cruise control function will automatically maintain the selected speed.

The accelerator can be used to temporarily increase speed, up to a maximum 30 km/h (18.64 mi) more than the selected speed, without deactivating the system (e.g. overtake).

If the speed is increased by more than 30 km/h (18.64 mi), the system will be deactivated (status changes from SET to ON).

When throttle is released, the motorcycle will return to the selected cruising speed. By exceeding the maximum threshold set for each gear in the previous table, the system will be deactivated (status changes from SET to ON).

Besides, the system deactivates (going from SET to ON status, flashing warning light) in the event of one of the following conditions:

- Engaging the clutch;
- Engaging the front/rear brake;
- Downshifting to gear 3 or putting the gearbox in neutral;
- Press the Cruise Control button with a short press;
- If the engine RPM limiter intervenes;
- If traction control intervenes;
- If the motorcycle negotiates a particularly steep uphill or downhill gradient.

The system switches off completely (switching from SET to OFF state), the stored speed setting is cancelled and the relative instrument panel indicator lamp extinguishes in any of the following conditions:

- Cruise Control button pressed and held;
- Run-OFF switch activated;
- Engine switch off (key-OFF).

In case of error.

## System ABS

The ABS system is a device that prevents wheel locking in case of an emergency braking, thus increasing vehicle stability when braking, compared with a conventional braking system.

The ABS system enhances control over the vehicle, taking into consideration never to exceed the physical limits of vehicle grip on the road. The rider is fully responsible for riding at a suitable speed based on weather and road conditions, always leaving an appropriate safety margin.

Under no circumstances can the ABS system compensate for the rider's misjudgment or improper use of brakes.

### NOTE

**WHEN THE ABS SYSTEM STARTS WORKING, A VIBRATION IS FELT ON THE BRAKE LEVER.**



**THE ANTILOCK BRAKING SYSTEM OF THE WHEEL DOES NOT PREVENT FALLS WHILE CORNERING.**

**AN EMERGENCY BRAKING WITH THE VEHICLE INCLINED, HANDLEBAR TURNED, ON UNEVEN OR SLIPPERY ROADS, OR WITH POOR GRIP, CREATES A LACK OF STABILITY DIFFICULT TO HANDLE. RIDE CAREFULLY AND SENSIBLY AND ALWAYS BRAKE GRADUALLY.**

**DO NOT SPEED RECKLESSLY. THE VEHICLE GRIP ON THE ROAD IS SUBJECT TO LAWS OF PHYSICS WHICH NOT EVEN THE ABS SYSTEM CAN ELIMINATE.**

Upon starting the vehicle, after the initial instrument panel check, the ABS warning light flashes until a speed of 5 kph (3.1 mph) is exceeded and then it switches off or continues to flash even after exceeding the speed of 5 kph (3.1 mph).

If the ABS warning light continues flashing or is permanently on, a failure has been detected and the ABS has been automatically deactivated.

In this case carry out the following operations:

- stop the vehicle;
- key OFF-ON;
- ride over 5 km/h (3.1 mph): the ABS warning light must be turned off;
- the ABS system is working.

If the ABS disabled indication remains:

#### **NOTE**

**SHOULD THIS OCCUR, CONTACT AN aprilia Official Dealer.**

#### **NOTE**

**THE ABS SYSTEM HAS BEEN DESIGNED AND DEVELOPED, CONSISTENTLY WITH THE REST OF THE VEHICLE, TO BE USED ON TARMAC ROADS AND IT IS NOT SUITABLE FOR OFF-ROAD USE.**

**IF THE VEHICLE IS USED ON UNSURFACED AND/OR SPECIFICALLY ROUGH ROADS, THE ABS SYSTEM MAY GET DISABLED AUTOMATICALLY; IN ANY CASE, THE BRAKING SYSTEM WORKS PERFECTLY WELL AS A TRADITIONAL NON-ABS BRAKING SYSTEM AND PROVIDES A STANDARD STOP CAPACITY.**

**IN ORDER TO REACTIVATE THE SYSTEM JUST SHUT OFF AND START THE VEHICLE UP AGAIN AND RIDE OVER 5 km/h (3.1 mph).**



THE ABS SYSTEM ACTS ON BOTH THE FRONT AND REAR WHEELS BY OBTAINING INFORMATION FROM THE ROTATION/ LOCKING TONE WHEELS. ALWAYS CHECK THAT THE TONE WHEEL IS CLEAN, AND REGULARLY CHECK THAT THE DISTANCE FROM THE SENSOR IS CONSTANT ON ALL 360 GRADES. SHOULD THE WHEELS BE REMOVED AND REFITTED, IT IS VERY IMPORTANT TO CHECK THAT THE DISTANCE BETWEEN TONE WHEEL AND SENSOR IS THE ONE SPECIFIED. FOR CHECKING AND ADJUSTMENT, CONTACT AN Authorised APRILIA Workshop.



IN THE CASE OF A MOTORCYCLE WITH THE ABS SYSTEM, BRAKE PADS WITH FRICTION MATERIALS THAT ARE NOT TYPE APPROVED WILL JEOPARDISE BRAKING, DRASTICALLY REDUCING RIDING SAFETY.

#### NOTE

THE SYSTEM SENSORS WITH A SIGNIFICANT ACCURACY IN READING THE TONE WHEELS CAN GENERATE, WITH THE MOTORCYCLE AT A STANDSTILL AND ENGINE ON, A SPEED INDICATION OF A FEW km / h (mi) IN THE DIGITAL DISPLAY.

SUCH BEHAVIOUR IS TO BE CONSIDERED NORMAL AND DOES NOT CREATE MALFUNCTIONS IN THE SYSTEM.



IF THE GAP FOR ONE OR BOTH SENSORS IS NOT WITHIN THE TOLERANCE INDICATED BELOW, TAKE THE MOTORCYCLE TO AN official Aprilia DEALER-SHIP

#### Characteristic

Distance between tone wheel and front sensor



0.3 - 2.00 mm (0.012 - 0.079 in)

**Distance between tone wheel and rear sensor**

0.3 - 2.00 mm (0.012 - 0.079 in)

## **System ATC (Aprilia Traction Control)**

ATC is a system that monitors and, if necessary, limits rear wheelspin under acceleration to increase vehicle stability.

While ATC improves vehicle control, it does not allow the physical handling limits of the vehicle to be exceeded. The rider is fully responsible for riding at a suitable speed based on weather and road conditions, always leaving an appropriate safety margin.

Under no circumstances can ATC compensate for any rider error or improper use of the throttle.



**THE TRACTION CONTROL SYSTEM CANNOT PREVENT FALLS WHILE CORNERING.**

**ACCELERATING SUDDENLY WHILE THE VEHICLE IS INCLINED OR WITH THE HANDLEBARS TURNED WILL PUT THE VEHICLE IN AN UNSTABLE STATE THAT IS EXTREMELY DIFFICULT TO RECTIFY.**

**DO NOT SPEED RECKLESSLY. LIMITS OF GRIP ARE DETERMINED BY LAWS OF PHYSICS WHICH EVEN THE ATC SYSTEM CANNOT OVERCOME.**

### **Characteristic**

**Distance between tone wheel and front sensor**

0.3 - 2.00 mm (0.012 - 0.079 in)

**Distance between tone wheel and rear sensor**

0.3 - 2.00 mm (0.012 - 0.079 in)

## **OPTION 01**

### **WARNING AND INDICATOR LIGHTS, KEY**

- **Indicator light flashing quickly:** when the system intervenes effectively on the traction control, the General Warning light flashes quickly

### **ATC SYSTEM DEACTIVATED MANUALLY**

Upon motorcycle start up, after the initial instrument panel check, if the system is deactivated, the ATC icon displays the zero flashing.

### **ATC SYSTEM ACTIVE**

Upon motorcycle start up, after the initial instrument panel check, the icon displays the set value

If the icon displays the zero permanently, a failure has been detected and the ATC has been automatically deactivated.

In this case carry out the following operations:

- stop the vehicle;
- key OFF-ON;
- reactivate the system manually
- ATC system working correctly.

If the 'ATC system deactivated' indication persists:

**NOTE**

**SHOULD THIS OCCUR, CONTACT AN aprilia Official Dealer.**

**OPTION 02****WARNING AND INDICATOR LIGHTS, KEY**

- **Indicator light off:** a system active after exceeding 5 km/h (3.1 mph) after switching on the panel;
- **Indicator light continuously lit:** with the system deactivated on purpose or if there is a malfunction;
- **Indicator light flashing slowly:** with system active after key-on before exceeding 5 Km/h (3.1 mph) or in the event of certain malfunctions causing the ATC level to be locked (ATC settings no longer modifiable);
- **Indicator light flashing quickly:** when the system intervenes effectively on the traction control.

**ATC SYSTEM DEACTIVATED MANUALLY**

When starting the vehicle, after the instrument panel initial check cycle, if the system is deactivated, the ATC warning light remains lit until the rider decides to activate the system.

**ATC SYSTEM ACTIVE**

When starting the vehicle, after the instrument panel initial check cycle, the ATC warning light flashes if the system was active at the previous key-off (and is therefore still active) and continues flashing until vehicle speed exceeds 5 km/h (3.1 mph), after which it extinguishes.

If the ATC warning light is permanently on, a failure has been detected and the ATC has been automatically deactivated.

In this case carry out the following operations:

- stop the vehicle;
- key OFF-ON;
- reactivate the system manually
- ride over 5 km/h (3.1 mph): the ATC warning light must be turned off;
- ATC system working correctly.

If the 'ATC system deactivated' indication persists:

#### **NOTE**

**SHOULD THIS OCCUR, CONTACT AN aprilia Official Dealer.**



**THE ATC SYSTEM ACTS ON REAR WHEEL BY OBTAINING INFORMATION FROM THE ROTATION/LOCKING TONE WHEELS FITTED ON BOTH WHEELS. ALWAYS CHECK THAT THE TONE WHEELS ARE CLEAN, AND REGULARLY CHECK THAT THE GAP BETWEEN THE TONE WHEEL AND THE SENSOR IS CONSTANT AROUND THE ENTIRE CIRCUMFERENCE OF THE TONE WHEEL ITSELF. SHOULD THE WHEELS BE REMOVED AND REFITTED, IT IS VERY IMPORTANT TO CHECK THAT THE DISTANCE BETWEEN TONE WHEEL AND SENSOR IS THE ONE SPECIFIED. FOR CHECKING AND ADJUSTMENT, CONTACT AN Authorised APRILIA Workshop**

#### **NOTE**

**IN CASE OF EXTENDED REAR WHEEL ROTATION WITH THE FRONT ONE LOCKED (BURNOUT, MOTORCYCLE ON THE CENTRE STAND, ETC.) THE SYS-**

**TEM CAN BE DEACTIVATED AUTOMATICALLY WITH STEADY LIGHTING OF THE ATC WARNING LIGHT.**

**TO REACTIVATE, TURN THE IGNITION SWITCH OFF AND THEN ON AGAIN AND SELECT THE REQUIRED SETTING.**

#### **NOTE**

**THE SYSTEM SENSORS WITH A SIGNIFICANT ACCURACY IN READING THE TONE WHEELS CAN GENERATE, WITH THE MOTORCYCLE AT A STANDSTILL AND ENGINE ON, A SPEED INDICATION OF A FEW km / h (mi) IN THE DIGITAL DISPLAY.**

**SUCH BEHAVIOUR IS TO BE CONSIDERED NORMAL AND DOES NOT CREATE MALFUNCTIONS IN THE SYSTEM.**

### **ADD system (Aprilia Dynamic Damping)**

ADD (Aprilia Dynamic Damping) is an integrated system that controls the semi-active suspensions and electrically operated preload of the rear shock absorber only.

The system adjusts the fork and shock absorber damping in real time, to provide the best riding comfort and maintain motorcycle trim as steady as possible during the ride.

The system works independently via a dedicated ECU; no adjustments are necessary, except for the preload of the rear single shock absorber.

With the motorcycle off, the suspensions are rigid, because they are not being operated.

The preload of the rear shock absorber can be manually adjusted on four levels, plus a fifth so-called automatic one. With key-on, the level set on the instrument panel before the last key-off is maintained. The automatic level is highlighted on the display of the instrument panel by symbols, a helmet and suitcase that slowly scroll in sequence.

The automatic level independently adjusts the preload based on the vehicle load, so as to maintain the height steady as much as possible.

The system works in two phases:

1) With the vehicle at a standstill, the engine running, gear in idle, crutch closed, the system performs a first overall preload adjustment if certain signal constance conditions are met.

2) With the vehicle moving, the system continuously monitors various signals coming from the vehicle and if certain signal constance conditions are met, it acts on the preload to find the ideal position.

If the system has already reached the ideal position, it will make no further adjustments.

An automatic adjustment of the preload is highlighted on the digital display by symbols, a helmet and suitcase, that scroll quickly in sequence, to then return to slow scrolling when the system has completed the adjustment.

Depending on the type of fault, the suspensions may work in either medium or maximum damping.

If there is a failure in the ADD system, the two helmets and the suitcase blink together on the display of the instrument panel, and the red GENERAL WARNING light stays permanently on. Depending on the type of fault, the suspensions may work in either medium rigidity or become fully rigid.

#### **WARNING**

**IN THE EVENT OF FAULT, FOR SAFETY REASONS, SLOW DOWN THE VEHICLE**

**DUE TO ELECTRICAL CONSUMPTION REASONS, THE ELECTRICAL PRELOAD ONLY WORKS WITH THE ENGINE RUNNING (LEVEL ADJUSTMENT IS LOCKED WHILE THE ENGINE IS OFF). IF THE ENGINE IS NOT STARTED WITHIN 15 SECONDS FROM KEY-ON, THE ELECTRONIC SUSPENSIONS ARE FOR THE SAME**

**REASONS TURNED OFF (AND THEREFORE LEAD TO MAXIMUM DAMPING) AND ARE REACTIVATED WHEN THE ENGINE IS ACTUALLY STARTED.**

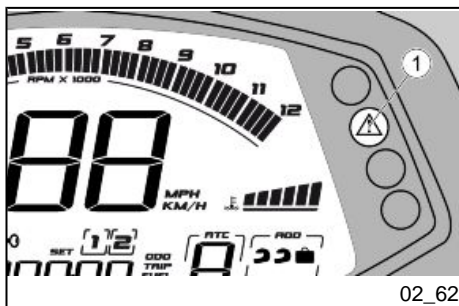

## Immobilizer system operation (02\_62)

For enhanced theft protection, the vehicle is equipped with an electronic immobilizer system that is activated automatically when the ignition key is removed.

Keep the second key in a safe place since it is not possible to make a copy if it gets lost. This would imply replacing numerous parts of the vehicle (besides the locks).

Each key in the grip has an electronic device - transponder - which modulates the radio frequency signal emitted by a special built-in aerial in the switch when the vehicle is started.

The modulated signal is the "password" by which the appropriate central unit recognises the key and only after this occurs, it allows the engine start-up.

### CAUTION

**THE IMMOBILIZER SYSTEM CAN MEMORISE UP TO FOUR KEYS.**

**DATA STORAGE OPERATION CAN ONLY BE PERFORMED AT THE DEALER'S.**

**DATA STORAGE PROCEDURE CANCELS THE EXISTING CODES. THEREFORE, IF A CUSTOMER WANTS TO PROGRAM SOME NEW KEYS, S/HE SHOULD GO TO THE DEALER TAKING ALL THE KEYS S/HE WANTS TO ENABLE.**

With the ignition key OFF, immobilizer operation mode is indicated by a warning light (1) placed on the instrument panel

The light goes off after 50 h

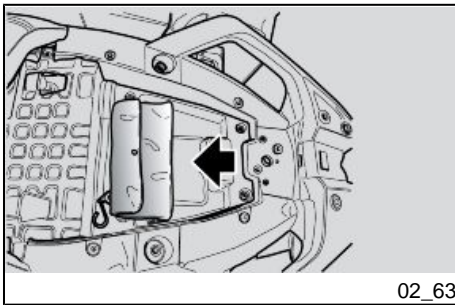

### Glove/tool kit compartment (02\_63)

Remove the passenger saddle to have access to the glove-box / toolkit compartment.

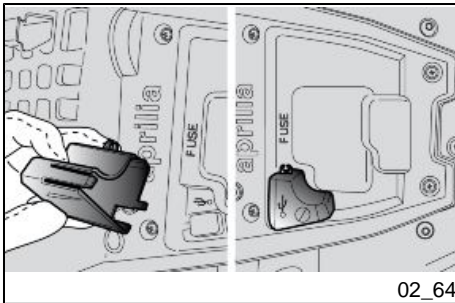

### USB Port (02\_64, 02\_65, 02\_66)

There is USB port in the glove-box/toolkit.

To use it, remove the cover and the protective plug.



**TO AVOID THAT WATER AND/OR HUMIDITY CAN DAMAGE THE USB PORT, USE THE PROTECTIVE COVER, EVEN WHEN A DEVICE IS CONNECTED.**



**THE INCLUDED USB PORT IS COMPATIBLE WITH DEVICES OF THE FOLLOWING BRANDS: Apple iPhone, Apple iPod, Apple iPod Nano, Apple iPod Touch, Blackberry Pearl, Blackberry 8xxx IT IS NOT COMPATIBLE WITH DEVICES FOR MOTOROLA PRODUCTS.**





**IF A USB DEVICE IS CONNECTED, ENSURE THE CORRECT POSITIONING OF THE CABLE TO AVOID THAT IT WILL BE SMASHED.**

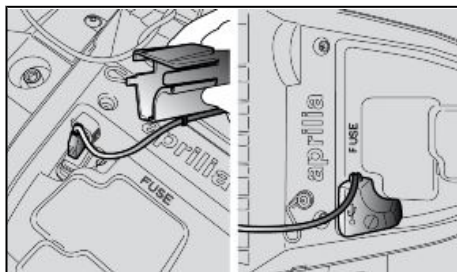

02\_65

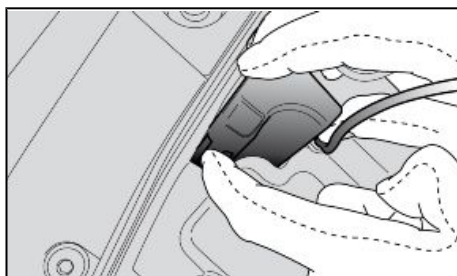

02\_66

To remove the cover, press the locking tongue.

The USB port is activated once the key is turned to position «ON».

#### **WARNING**

**PROLONGED USE OF THE PLUG SOCKET MAY RESULT IN PARTIAL DISCHARGE OF THE BATTERY.**

#### **USB PORT**

Output voltage

(5.00+/-0.25) DC

### Identification (02\_67, 02\_68)

Write down the chassis and engine number in the specific space in this booklet. The chassis number is handy when purchasing spare parts.

#### CAUTION



**CHANGING THE IDENTIFICATION CODE IS A CRIME THAT MAY BE PUNISHED WITH SERIOUS CRIMINAL CHARGES. FURTHERMORE, THE LIMITED WARRANTY FOR NEW VEHICLES WILL BE CANCELLED IF THE VEHICLE IDENTIFICATION NUMBER (VIN) HAS BEEN MODIFIED OR CANNOT BE QUICKLY DETERMINED.**

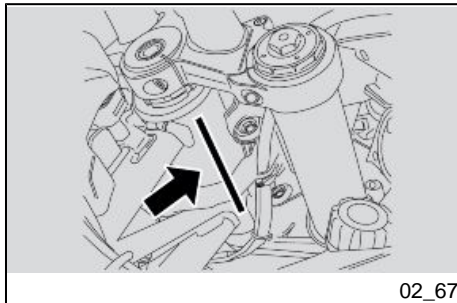

#### CHASSIS NUMBER

The chassis number is stamped on the right side of the headstock.

Chassis No. ....

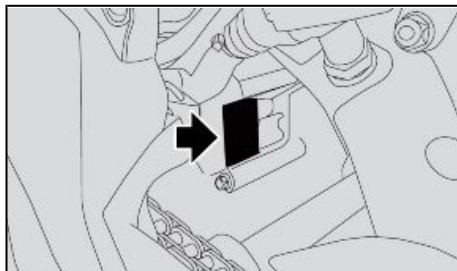

02\_68

## ENGINE NUMBER

The engine number is printed on the base of the engine crankcase, left hand side.

Engine No. ....

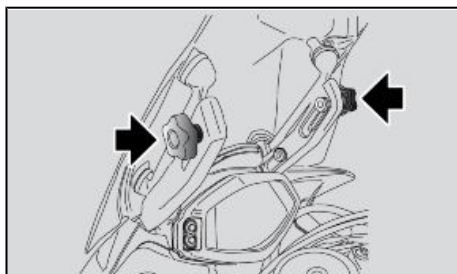

02\_69

## Adjusting the windscreen (02\_69)

It is possible to adjust the windscreen manually as follows:

- upholding the windscreen and working on both its sides, loosen the two knobs.
- adjust the windscreen to the desired position.
- upholding the windscreen and working on both its sides, tighten the two knobs.

**Provision for the installation of accessories (02\_70, 02\_71, 02\_72, 02\_73, 02\_74, 02\_75, 02\_76, 02\_77, 02\_78, 02\_79, 02\_80, 02\_81, 02\_82, 02\_83, 02\_84, 02\_85)**

## SIDE PANNIERS

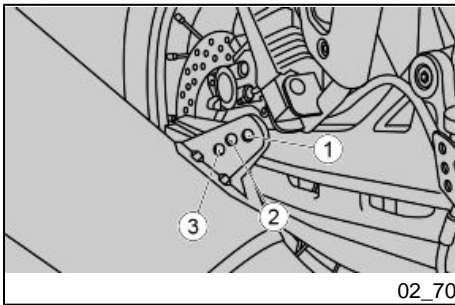
**CAUTION**

**IT IS NECESSARY TO ADJUST THE CORRECT HEIGHT OF THE EXHAUST MUFFLER BASED ON THE TYPE OF EQUIPMENT.**

- **THE EXHAUST MANIFOLD MUST BE IN POSITION (1) WHEN THE VEHICLE HAS PLASTIC SUITCASES WITH PAINTED COVER.**
- **IT IS RECOMMENDED TO ADJUST THE EXHAUST MANIFOLD TO POSITION (2), OR TO POSITION (1) WHEN THE VEHICLE HAS ALUMINIUM SUITCASES (AS STANDARD ON Caponord 1200 Rally).**
- **IF THE VEHICLE HAS NO SUITCASES THE EXHAUST MANIFOLD CAN BE ADJUSTED TO THE FAVOURITE POSITION**



**DO NOT LOAD MORE THAN 5 kg (11.02 lb) FOR EACH BAG, AN EXCESSIVE LOAD COULD DAMAGE IT**

**(Caponord 1200 Rally)**

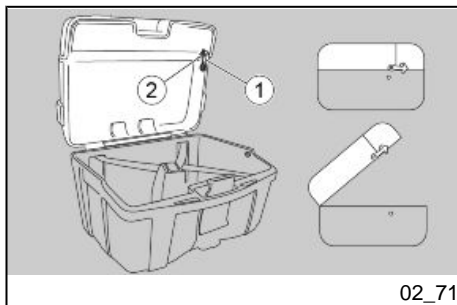

### COVER OPENING

- Rest the vehicle on its stand.
- To open the suitcase cover, the hooks (1) inside must be placed on the locking pins (2) of the cover

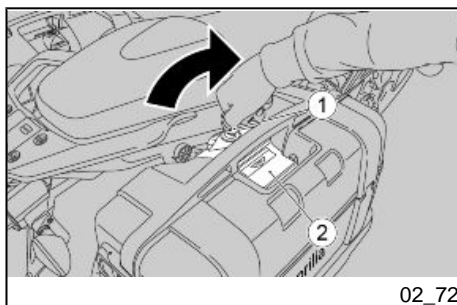

- Introduce the key (3) in the pannier cover handle (4).
- Turn the key (3) clockwise.

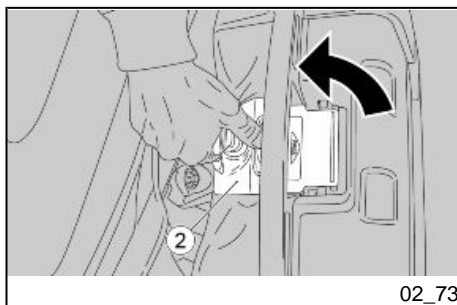

- Press the pannier cover handle button (2) and release it.

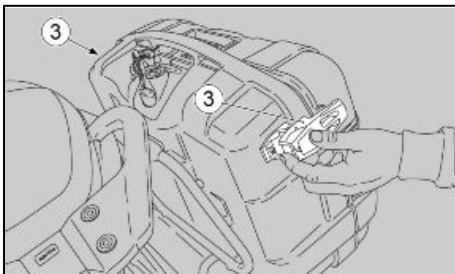

02\_74

- Open the two side hooks (3)

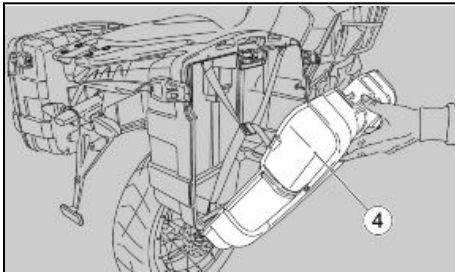

02\_75

- Open the cover (4)

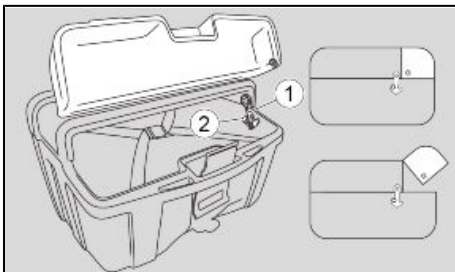

02\_76

#### PARTIAL COVER OPENING

- To partially open the suitcase cover, the hooks (1) inside must be placed on the locking pins (2) of the cover

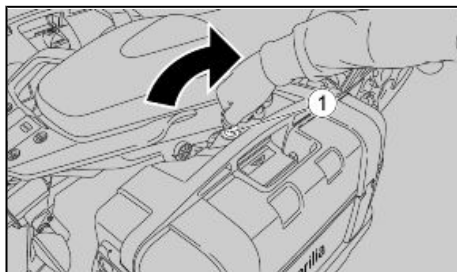

02\_77

**REMOVAL**

- Introduce the key (1) and turn it clockwise.

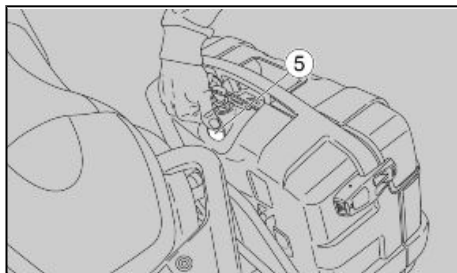

02\_78

- Press the suitcase release button (5).

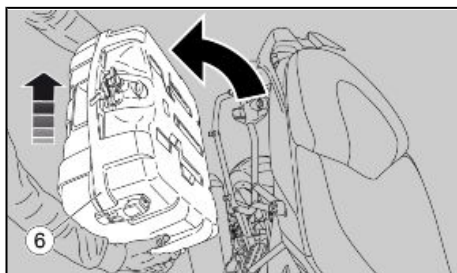

02\_79

- Move the suitcase to the side (6), lift it and release it from the pins on the support.

## (Caponord 1200 Travel Pack / Caponord 1200)

(if applicable)

### COVER OPENING

- Rest the vehicle on its stand.
- Introduce the key (1) in the pannier cover handle (2).
- Turn the key (1) anticlockwise.

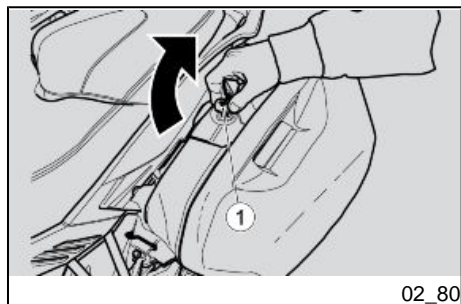

- Lift the handle (2) and free it from the cover (3).
- Open the cover (3).

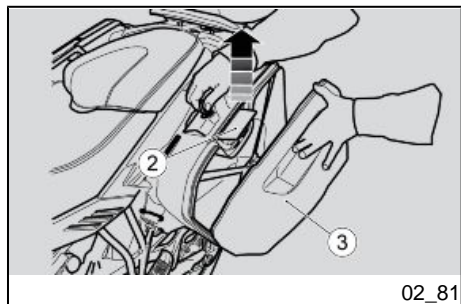



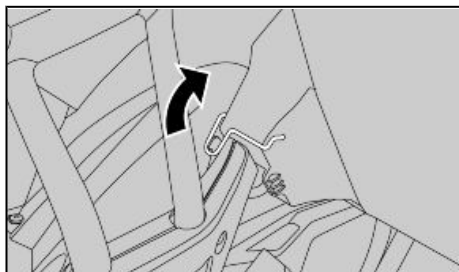

02\_82

**REMOVAL**

- Lift the safety stopper

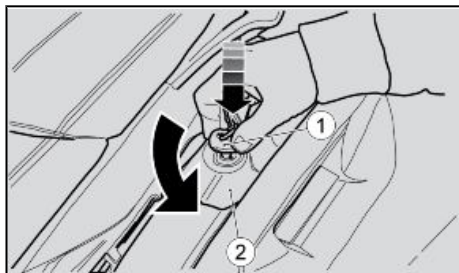

02\_83

- Introduce the key (1) in the pannier cover handle (2). Turn the key (1) anti-clockwise.
- Pull the pannier and free it from the stopper
- Lift it and unthread it from the fixing hooks

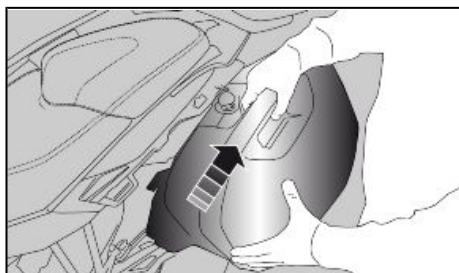

02\_84



# CAPONORD 1200

**aprilia**



**Chap. 03**  
**Use**

## Checks (03\_01)

### CAUTION



**BEFORE RIDING, ALWAYS PERFORM A PRELIMINARY CHECK OF THE VEHICLE TO ENSURE CORRECT AND SAFE OPERATION. FAILURE TO DO SO MAY LEAD TO SERIOUS PERSONAL INJURY OR DAMAGE TO THE VEHICLE. DO NOT HESITATE TO CONTACT AN OFFICIAL Aprilia DEALER IF YOU DO NOT UNDERSTAND HOW SOME CONTROLS WORK OR IF A MALFUNCTION IS DETECTED OR SUSPECTED. CHECKING TAKES VERY LITTLE TIME BUT CONSIDERABLY INCREASES SAFETY.**

### CAUTION

**ACCORDING TO THE TIME ELAPSED FROM THE MOMENT THE KEY IS SET TO "KEY ON" UNTIL THE ENGINE STARTS, THE STOP LIGHT CAN BE ACTIVATED FOR ABOUT HALF A SECOND OR NOT.**

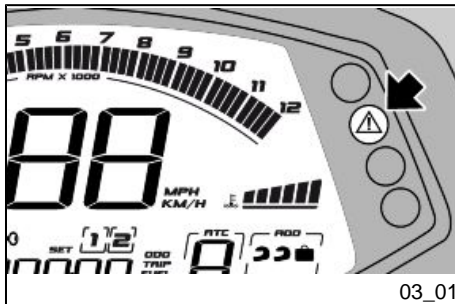

This vehicle has been programmed to indicate in real time any operation failure stored in the electronic control unit memory.

Every time the ignition switch is turned to "KEY ON", the alarm LED warning light turns on for about three seconds on the instrument panel.

**PRE-RIDE CHECKS**

Front and rear disc brake	Check for proper operation. Check brake lever empty travel and brake fluid level. Check for leaks. Check brake pads for wear. If necessary top-up with brake fluid.
Throttle grip	Check that the throttle functions smoothly and can be fully opened and closed in all steering positions. Adjust and/or lubricate if necessary.
Engine oil	Check and/or top-up as required.
Wheels/ tyres	<p>Check that tyres are in good conditions. Check inflation pressure, tyre wear and potential damage.</p> <p>Remove any possible strange body that might be stuck in the tread design.</p>
Brake levers	<p>Check they function smoothly.</p> <p>Lubricate the joints and adjust the travel if necessary.</p>
Clutch	Check for proper operation. Check clutch lever free play and fluid level. Check for leaks. Top-up the fluid if necessary; the clutch must work without gripping and/or sliding.

Steering	Check that the rotation is uniform, smooth and there are no signs of clearance or slackness.
Side stand / Centre stand (if fitted)	<p>Check it works properly. Check that there is no resistance when the side stand is pulled up and down and that the spring tension makes it snap back to its rest position.</p> <p>Lubricate couplings and joints if necessary.</p> <p>Check the safety switch for correct operation.</p>
Clamping elements	<p>Check that the clamping elements are not loose.</p> <p>Adjust or tighten them as required.</p>
Drive chain	Check it for backlash.
Fuel tank	<p>Check the coolant level and refill if necessary.</p> <p>Check the circuit for leaks or obstructions.</p> <p>Check that the tank cap closes correctly.</p>
Coolant	Fluid level inside the expansion tank should be between the ' <b>FULL</b> ' and ' <b>LOW</b> ' reference marks.
Engine stop switch (ON - OFF)	Check function.

Lights, warning lights, horn, rear stop light switch and electrical devices

Check function of horn and lights. Replace bulbs or repair any faults noted.

Tone wheels

Check that the tone wheels are perfectly clean and in good conditions.

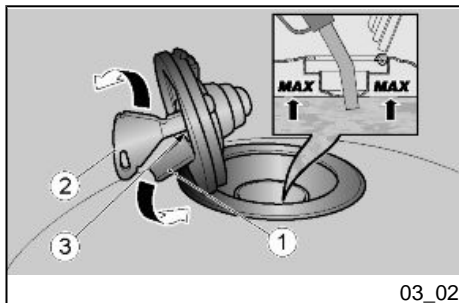

## Refuelling (03\_02)

To refuel:

- Lift the cover (1).
- Introduce the key (2) in the fuel tank cap lock (3).
- Turn the key clockwise, pull and open the fuel tank lid.

## Characteristic

### Fuel tank (reserve included)

24 l (5.28 UK gal; 6.34 US gal)

### Fuel reserve

4 l (0.88 UK gal; 1.06 US gal)

- Refuel.

## CAUTION



**DO NOT ADD ADDITIVES OR ANY OTHER SUBSTANCES TO THE FUEL.**

**WHEN USING A FUNNEL, ENSURE THAT IT IS PERFECTLY CLEAN.**



**WHEN FILLING THE TANK COMPLETELY, DO NOT FILL BEYOND THE LOWER EDGE OF THE RECESS (SEE FIGURE).**

**WHEN REFUELLING, AVOID FUEL LEAKS THAT MAY CAUSE DAMAGES TO PROPERTIES AND/OR PEOPLE AND FIRE HAZARD.**

**DURING REFUELLING, AVOID THE USE OF ELECTRIC DEVICES AND/OR MOBILE PHONES, BECAUSE FUEL VAPOURS MAY CAUSE DAMAGE TO OBJECTS AND/OR PERSONAL INJURIES.**

**after refuelling:**

- The fuel cap may only be refitted with the key (2) inserted.
- Once the key (2) is inserted, press the cap to close it again.
- Remove the key (2).
- Close the cover (1).



**MAKE SURE THE CAP IS TIGHTLY CLOSED.**

## **Rear shock absorbers adjustment (03\_03, 03\_04)**

**(Caponord 1200 Rally/Travel Pack)**

This version is configured for use with semi-active shock absorbers



**CAUTION**

**THE REAR SHOCK ABSORBER IS ELECTRONICALLY MANAGED BY THE VCU AND CAN BE SET WITH THE CONTROLS ON THE INSTRUMENT PANEL TO ALWAYS HAVE IDEAL RIDING CONDITIONS**

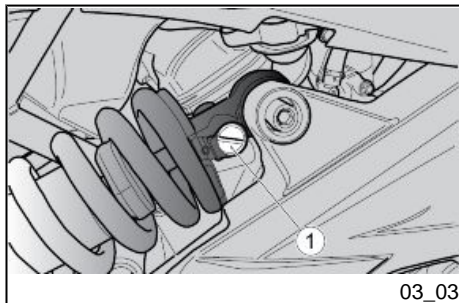
**(Caponord 1200)**

The rear suspension consists of a spring-shock absorber unit linked to the frame via Silent-block and to the rear fork.

To set vehicle suspension, the shock absorber has:

- a set screw (1) to adjust the hydraulic rebound damping;
- a set knob (2) to adjust spring (3) preloading.

**NOTE**

**IT IS POSSIBLE TO ADJUST THE HEIGHT OF THE REAR PART OF THE VEHICLE IN ORDER TO PERSONALIZE THE STRUCTURE.**

**NOTE**

**CARRY OUT MAINTENANCE OPERATIONS AT HALF THE INTERVALS SPECIFIED IF THE VEHICLE IS USED IN PARTICULAR RAINY OR DUSTY CONDITIONS, OFF ROAD OR FOR TRACK USE.**

**CAUTION**

**DO NOT STRAIN THE ROTATION OF ADJUSTMENT SETTINGS (1)(2) BEYOND THE END OF THE STROKE IN BOTH SENSES, IN ORDER TO AVOID ANY DAMAGE.**

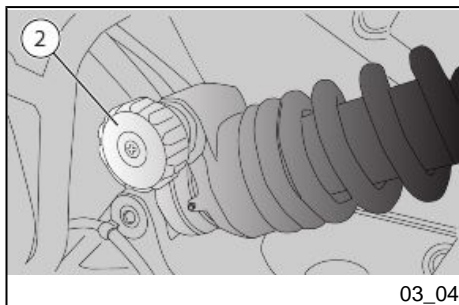

Standard rear shock absorber setting is adjusted to suit most high and low speed riding conditions, to transport the rider plus luggage.

However, this set can be modified for specific needs according to vehicle use.



**BEFORE MAKING ANY ADJUSTMENTS, WAIT FOR THE ENGINE AND SILENCER TO COOL COMPLETELY.**

#### **CAUTION**



**SET SPRING PRELOADING AND REBOUND DAMPING BASED ON THE VEHICLE'S USAGE CONDITIONS. IF SPRING PRELOADING IS INCREASED, THE HYDRAULIC REBOUND DAMPING (1) SHOULD BE INCREASED ACCORDINGLY TO AVOID SUDDEN JERKS WHEN RIDING. SHOULD YOU NEED ANY ASSISTANCE, CONTACT AN Official aprilia Dealer.**

### **Rear shock absorbers setting (03\_05, 03\_06)**

**(Caponord 1200 Rally/Travel Pack)**

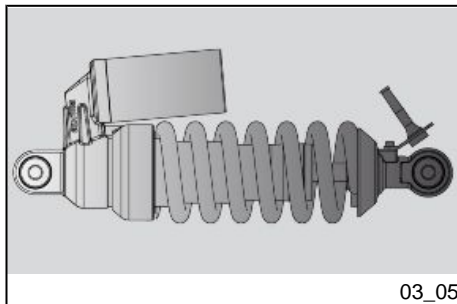

03\_05

This version is configured for use with semi-active shock absorbers

#### CAUTION

**THE REAR SHOCK ABSORBER IS ELECTRONICALLY MANAGED BY THE VCU AND CAN BE SET WITH THE CONTROLS ON THE INSTRUMENT PANEL TO ALWAYS HAVE IDEAL RIDING CONDITIONS**

The system is identified by a series of symbols that correspond to a certain type of specific setting:

- The helmet corresponds to the motorcycle setting with only the rider on board
- The helmet and suitcase corresponds to the motorcycle setting with the rider and luggage
- Two helmets correspond to the motorcycle setting with the rider and passenger
- Two helmets and a suitcase correspond to the motorcycle setting with rider, passenger and luggage
- Two helmets and a suitcase blinking in sequence correspond to the motorcycle setting in automatic mode

#### NOTE

**WITH THE MOTORCYCLE'S INSTRUMENT PANEL SWITCHED OFF, AT THE NEXT IGNITION OF THE SYSTEM THE ADD KEEPS THE SETTINGS CHOSEN PREVIOUSLY.**

**(Caponord 1200)**

## REAR SHOCK ABSORBER - ADJUSTMENT

	Spring preloading	Hydraulic rebound damping
Rider	Open 0 turns (turn counter-clockwise)	Open 17 clicks (turn counter-clockwise)
Rider+Empty luggage	Open 4 turns (turn counter-clockwise)	Open 14 clicks (turn counter-clockwise)
Rider+luggage	Open 8 turns (turn counter-clockwise)	Open 11 clicks (turn counter-clockwise)
Rider+Passenger	Open 16 turns (turn counter-clockwise)	Open 8 clicks (turn counter-clockwise)
Rider+Passenger +Luggage	Open 20 turns (turn counter-clockwise)	Open 5 clicks (turn counter-clockwise)

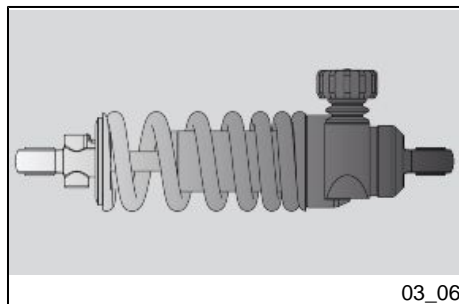

### NOTE

**BEFORE PROCEEDING WITH THE ADJUSTMENT OF THE SHOCK ABSORBER, CLOSE THE ADJUSTERS COMPLETELY (CLOCKWISE).**

### Front fork adjustment (03\_07, 03\_08)

(Caponord 1200 Rally/Travel Pack)

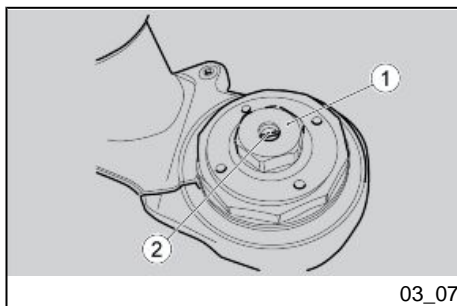

This version is configured for use with semi-active shock absorbers

Depending on the rider's requirements, it is possible to only modify the preload on the right stanchion, working on the adjustment nut of the upper plug.

The standard setting of the stanchion is obtained by starting off from a fully closed nut (clockwise) and opening it (anti-clockwise) by 5 turns.

#### CAUTION

**THE ONLY ADJUSTMENT POSSIBLE CAN BE PERFORMED ON THE RIGHT STANCHION, WHILE THE LEFT ONE CANNOT BE ADJUSTED, SINCE IT IS ELECTRONICALLY MANAGED.**

#### (Caponord 1200)

- Operating the front brake lever, press the handlebar repeatedly to send the fork fully down. The shock absorber should compress and extend smoothly with no signs of oil leakage on the stanchions.
- Check the tightening of all the elements and the correct operation of the front and rear suspension joints.

#### CAUTION

**PLEASE CONTACT AN Official Aprilia Dealer TO HAVE THE FRONT FORK OIL CHANGED AND ITS OIL SEALS REPLACED.**

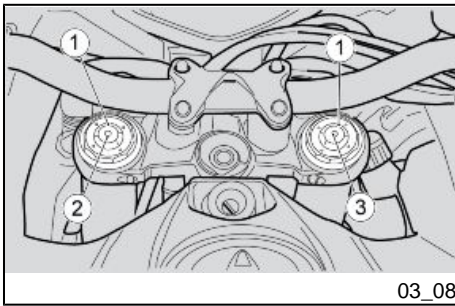

The front suspension consists of a hydraulic fork connected to the headstock by means of two plates.

For adjusting the suspension setup, each stanchion has an upper nut (1) for adjusting the spring preload.

The left hand stem is also equipped with an upper adjuster screw (2) for adjusting hydraulic rebound damping.

The right hand stem is equipped with an upper set screw (3) for adjusting compression damping.

Depending on the rider's requirements, it is possible to modify stem setting; bear in mind that the standard settings are the following:

- Preload (fully screwed), open by 5 turns (for both stanchions);
- Hydraulic braking in extension (fully screwed), open by 10 turns (left stanchion);
- Hydraulic braking in compression (fully screwed), open by 10 turns (left stanchion).

#### CAUTION

**TO PREVENT DAMAGE, DO NOT FORCE THE ADJUSTER (1-2) BEYOND THE RESPECTIVE END OF TRAVEL IN EITHER DIRECTION. USE THE SAME SPRING PRELOAD SETTINGS FOR BOTH STEMS: RIDING THE VEHICLE WITH DIFFERENT SETTINGS FOR THE TWO STANCHIONS REDUCES STABILITY. WHEN SPRING PRELOAD IS INCREASED, REBOUND DAMPING MUST ALSO BE INCREASED TO PREVENT EXCESSIVE SUSPENSION KICKBACK WHEN RIDING.**

#### CAUTION



**TO COUNT THE NUMBER OF RELEASES AND/OR REVOLUTIONS OF ADJUSTMENT SETTINGS (1 - 2) ALWAYS START FROM THE MOST RIGID SETTING (WHOLE CLOCKWISE ROTATION OF THE SETTING). DO NOT FORCE THE SET**

**SCREWS (1 - 2) TO TURN BEYOND THE END OF THE STROKE ON BOTH SIDES SO AS NOT DAMAGE THEM.**

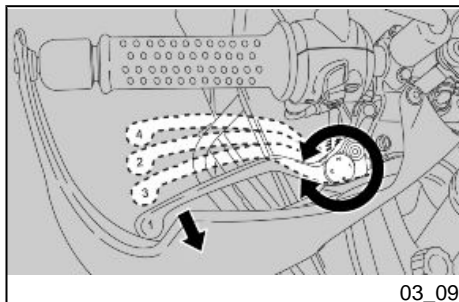

### **Justering af greb til forbremse (03\_09)**

Adjust the distance between the lever end and the hand grip by turning the set screw.

To adjust: push the control lever forward and turn the set screw until the arrow points at the desired number.

### **Clutch lever adjustment (03\_10)**

#### **CAUTION**

**CLEAN THE CLUTCH LEVER PIN FROM POSSIBLE DIRT ACCUMULATION OF GREASE.**

**THEN LUBRICATE THE PIN IF YOU ARE RIDING IN THE RAIN, ON WET ROADS OR AFTER THE VEHICLE HAS BEEN WASHED**

**For the lubricating type to be used, refer to the recommended products table.**

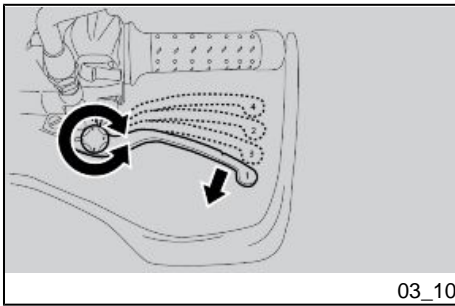

Adjust the distance between the lever end and the hand grip by turning the set screw.

To adjust: push the control lever forward and turn the set screw until the arrow points at the desired number.

## Running in

Running in is essential to ensure the durability of the vehicle. During the first 1000 Km (621.37 mi), observe the following rules to ensure the reliability and performance of the vehicle throughout its lifetime:

- Avoid full throttle starts and hard acceleration;
- Avoid hard or prolonged braking;
- Do not ride for prolonged periods at sustained high speed; preferably ride the motorcycle on varied routes with frequent, gentle acceleration and deceleration;
- Ride prudently to gradually gain familiarity with the motorcycle, testing progressively higher throttle apertures only as you gain confidence

### CAUTION

**THE FULL PERFORMANCE OF THE VEHICLE IS ONLY AVAILABLE AFTER THE SERVICE AT THE END OF THE RUNNING IN PERIOD.**

### Follow these guidelines:

- Do not twist the throttle grip abruptly and completely when the engine is working at a low revs, either during or after run-in.



- During the first 100 Km (62.14 miles) use the brakes gently, avoiding sudden or prolonged braking. That is to permit the adequate adjustment of the pad friction material to the brake discs.



**AFTER THE SPECIFIED MILEAGE, TAKE YOUR VEHICLE TO AN Official Aprilia Dealer FOR THE CHECKS INDICATED IN THE "AFTER-RUN-IN" TABLE IN THE SCHEDULED MAINTENANCE SECTION TO AVOID INJURING YOURSELF, OTHERS AND /OR DAMAGING THE VEHICLE.**

### **Starting up the engine (03\_11, 03\_12, 03\_13, 03\_14, 03\_15)**

**This vehicle is extremely powerful and must be used carefully and driven with caution and respect for its power and potential.**

**Do not carry objects in the top fairing (between the handlebar and the instrument panel) so that the handlebar can turn freely and the instrument panel is visible at all times.**



**EXHAUST FUMES CONTAIN CARBON MONOXIDE, AN EXTREMELY HARMFUL SUBSTANCE IF INHALED.**

**NEVER START THE ENGINE IN A CLOSED OR INSUFFICIENTLY VENTILATED SPACE.**



**FAILURE TO OBSERVE THIS WARNING COULD LEAD TO UNCONSCIOUSNESS AND EVEN DEATH DUE TO SUFFOCATION.**

## CAUTION

WITH THE SIDE STAND LOWERED, THE ENGINE MAY ONLY BE STARTED WITH THE GEARBOX IN NEUTRAL. IF YOU ATTEMPT TO ENGAGE A GEAR IN THIS CONDITION THE ENGINE WILL STOP.

WITH THE SIDE STAND RETRACTED, THE ENGINE MAY BE STARTED WITH THE GEARBOX IN NEUTRAL OR WITH GEAR ENGAGED AND THE CLUTCH LEVER PRESSED.

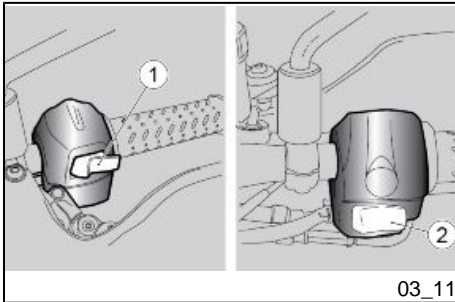

- Get onto the bike in riding position.
- Make sure that the stand has been fully retracted.
- Make sure the light switch (1) is set to the low beam light position.
- Set the engine stop switch (2) to RUN.
- Turn the key (3) and set the ignition switch to ON.

At this stage:

- On the instrument panel, all warning lights (4) and the backlighting are on for 2 seconds.
- The current value is instantly indicated on the instrument panel during regular vehicle riding.

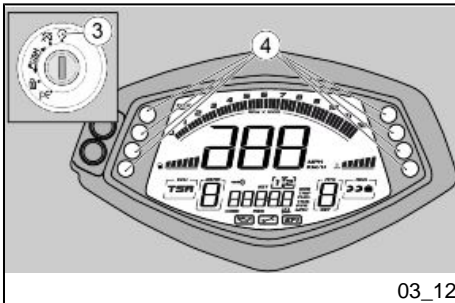

IF THE LOW FUEL WARNING LIGHT ON THE INSTRUMENT PANEL TURNS ON, REFUEL THE VEHICLE AT ONCE.

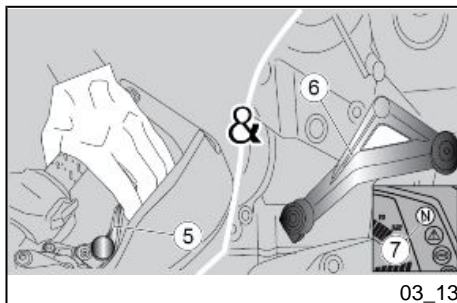

- Block at least one wheel by operating one brake lever.
- Pull the clutch lever (5) completely and set the gearshift lever (6) to neutral (green "N" indicator light (7) lit).
- There is a starter on the vehicle, controlled by the control unit, that starts working automatically whenever necessary (cold start).



**TO AVOID EXCESSIVE BATTERY CONSUMPTION, DO NOT HOLD DOWN THE STARTER BUTTON (2) MORE THAN TEN SECONDS.**

**IF THE ENGINE FAILS TO START AFTER THIS TIME, WAIT TEN SECONDS AND PRESS THE STARTER BUTTON (2) AGAIN.**

**PRESS THE STARTER BUTTON (2) BUT DO NOT ACCELERATE, AND RELEASE IT AS SOON AS THE ENGINE STARTS.**

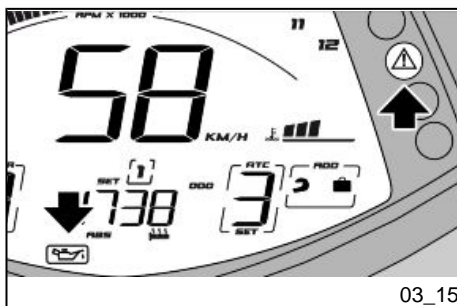
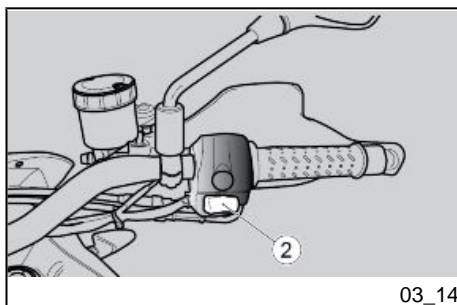

**IF THE ENGINE OIL PRESSURE ICON IS DISPLAYED AND THE GENERAL WARNING LIGHT IS BLINKING, THE OIL PRESSURE IN THE CIRCUIT IS TOO LOW.**

- Engage at least one brake lever and do not accelerate until you set off.



**DO NOT SET OFF SUDDENLY WHEN THE ENGINE IS COLD. RIDE AT LOW SPEED FOR SEVERAL KILOMETRES. THIS WILL ALLOW THE ENGINE TO WARM UP AND REDUCE POLLUTING EMISSIONS AND FUEL CONSUMPTION.**



**WHEN THE EFI ICON APPEARS AND THE GENERAL WARNING LIGHT IS PERMANENTLY ON WHILE THE ENGINE IS NORMALLY RUNNING, IT MEANS THE ECU HAS DETECTED SOME FAULT. CONTACT AN Official Aprilia Dealer ASAP.**

**WHEN THE EFI ICON APPEARS AND THE GENERAL WARNING LIGHT IS BLINKING WHILE THE ENGINE IS NORMALLY RUNNING, IT MEANS THE ECU HAS DETECTED SOME SEVERE FAULT. IMMEDIATELY CONTACT AN Official Aprilia Dealer.**

## **Ride by wire**

The vehicle is fitted with an innovative throttle control system, called RIDE BY WIRE, which ensures optimum engine performance, at all times, taking into account the rider's demand, the general operating conditions plus the external conditions (atmospheric pressure, temperature). If compared with traditional injection systems, it also allows an electronic control of the throttle, thus replacing the traditional cable. When riding at high altitudes, the RIDE BY WIRE system offsets the unavoidable loss of power (1% every 100 metres of slope due to the reduced concentration of oxygen in the air) by opening the throttle bodies. Therefore, the engine performance when torque demand is requested by means of the throttle is the same as when riding on level ground, thus shifting the characteristic power reduction to the highest speeds. As a result, throttles are fully open but the throttle grip is not fully twisted; therefore, in case

the throttle grip is further and fully twisted, the vehicle performance will not be further enhanced.

### Moving off / riding (03\_16, 03\_17, 03\_18, 03\_19, 03\_20, 03\_21)

#### CAUTION

IF, WHILE RIDING, THE LOW FUEL WARNING LIGHT (1) ON THE INSTRUMENT PANEL TURNS ON, IT MEANS THERE IS STILL SOME FUEL LEFT.

REFUEL AS SOON AS POSSIBLE.

#### CAUTION

WHEN TRAVELLING WITHOUT PASSENGERS, MAKE SURE THE PASSENGER FOOTRESTS ARE FOLDED UP.

#### CAUTION

PASSENGERS MUST BE SUITABLY INSTRUCTED ON HOW TO BEHAVE TO PREVENT DANGEROUS SITUATIONS WHEN RIDING.

BEFORE SETTING OFF, MAKE SURE THE STAND HAS BEEN COMPLETELY RETRACTED TO ITS POSITION.

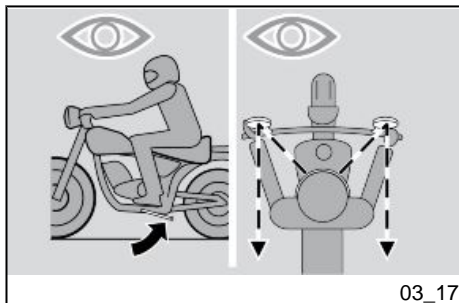
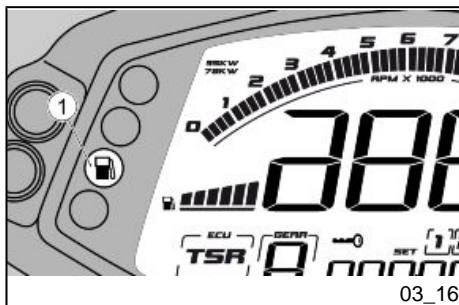

#### To start:

- Turn on the engine.
- Adjust the inclination of the rear-view mirrors to ensure proper visibility.

#### CAUTION



WITH THE VEHICLE AT A STANDSTILL, PRACTICE USING THE REAR-VIEW MIRRORS. THE MIRRORS ARE CONVEX, SO OBJECTS MAY SEEM FARTHER AWAY THAN THEY REALLY ARE. THESE MIRRORS OFFER A WIDE-ANGLE

**VIEW AND ONLY EXPERIENCE HELPS YOU JUDGE THE DISTANCE SEPARATING YOU AND THE VEHICLE BEHIND.**

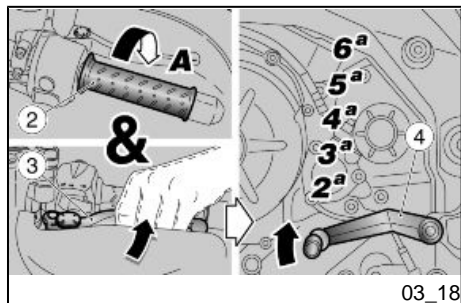

- With throttle grip (2) closed (**Pos. A**) and engine at idle, operate the clutch lever (3).
- Push the gearbox lever (4) downward to select the first gear.
- Release the clutch lever (activated during start-up).

#### **CAUTION**

**WHEN TURNING OFF THE VEHICLE, DO NOT RELEASE THE CLUTCH TOO QUICKLY OR SUDDENLY, AS THIS COULD CAUSE THE ENGINE TO STOP OR THE VEHICLE TO REAR UP ON THE BACK WHEEL. DO NOT ACCELERATE SUDDENLY WHEN RELEASING THE CLUTCH FOR THE SAME REASON.**

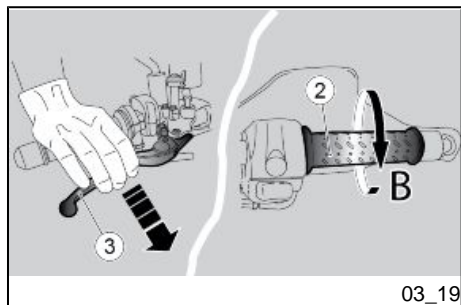

- Slowly release the clutch lever (3) and at the same time accelerate by slightly twisting the throttle grip (2) (**Pos. B**).

The vehicle starts moving forward.

- For the first kilometres travelled, limit the speed in order to warm up the engine.

- Accelerate gradually by twisting the throttle grip (2) (**Pos. B**) without exceeding the recommended rpm.

**To engage the second gear:**



**RIDE IN THE CORRECT GEAR AND SPEED FOR THE CONDITIONS.  
DO NOT CHANGE GEAR AT A TOO LOW RPM LEVEL.**

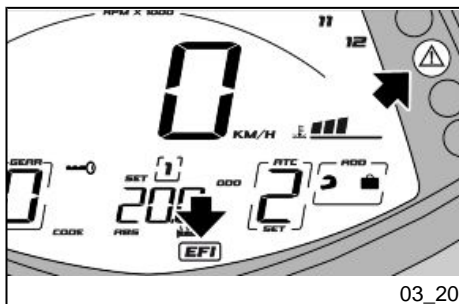

03\_20

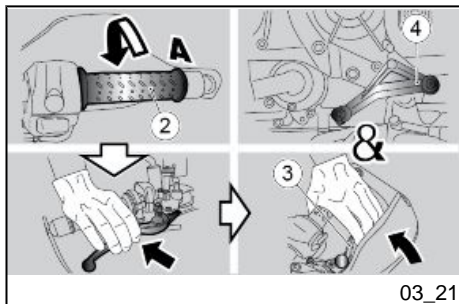

03\_21

- Release the throttle grip (2) (**Pos. A**), operate the clutch lever (3), lift the gearshift lever (4), release the clutch lever (3) and accelerate.
- Repeat the last two operations and engage a higher gear.



**IF THE ENGINE OIL PRESSURE ICON IS DISPLAYED AND THE GENERAL WARNING LIGHT IS ON DURING REGULAR ENGINE OPERATION, THIS MEANS THAT THE ENGINE OIL PRESSURE IN THE CIRCUIT IS TOO LOW.**

**IF THIS OCCURS, STOP THE ENGINE AND CONTACT AN APRILIA Official Dealer.**

**SHIFTING FROM A HIGHER TO A LOWER GEAR, CALLED "DOWNSHIFT", IS CARRIED OUT:**

- When riding downhill and when braking, in order to increase the braking power by using engine compression.
- When going uphill, when the engaged gear does not suit the speed (high gear, moderate speed) and the number of engine revs falls.

## CAUTION

**DOWNSHIFT ONE GEAR AT A TIME; WHEN SHIFTING TO A LOWER GEAR, DOWNSHIFTING MORE THAN ONE GEAR AT A TIME COULD OVERREV THE ENGINE; THAT IS, THE MAXIMUM RPM VALUE PERMITTED FOR THE ENGINE COULD BE EXCEEDED.**

- Release the throttle grip (2) (**Pos. A**)
- If necessary, pull the brake levers gently and reduce speed.
- Operate the clutch lever (3) and lower the gearshift lever (4) to engage a lower gear.
- Release the brake levers when it is operated.
- Release the clutch lever (3) and accelerate moderately.



**IF AN ENGINE OVER-TEMPERATURE ALARM APPEARS ON THE MULTI-FUNCTION DIGITAL DISPLAY, STOP THE ENGINE AND CHECK THE LEVEL OF COOLING LIQUID. IF THE LEVEL IS INSUFFICIENT, TOP IT UP AFTER HAVING COOLED DOWN THE ENGINE. START THE ENGINE RUNNING, CHECKING THAT THE WARNING LIGHT TURNS OFF. IF THE LEVEL IS THE RIGHT ONE AND/OR IF THE WARNING LIGHT CONTINUES TO STAY ON AFTER TOP-UP, CONTACT AN OFFICIAL Aprilia DEALER, USING A TOW TRUCK.X**

**IF THE TEMPERATURE INDICATOR CONTINUES BLINKING AFTER CHECKING THE COOLANT LEVEL, CONTACT AN Official Aprilia Dealer.**

**LEAVING THE KEY IN "KEY-OK" POSITION, IN ORDER TO AVOID THAT THE FANS STOP, CAUSING THE TEMPERATURE TO RISE FURTHER.**

**IF THE GENERAL WARNING LIGHT ACTIVATES ON THE INSTRUMENT PANEL DURING REGULAR ENGINE OPERATION, THIS MEANS THAT SOME FAILURES HAVE BEEN DETECTED.**

**IN MANY CASES THE ENGINE WILL CONTINUE TO OPERATE WITH LIMITED PERFORMANCE; IMMEDIATELY CONTACT AN Official Aprilia Dealer.**



**IN ORDER TO AVOID CLUTCH OVERHEATING, SHUT THE ENGINE OFF AS SOON AS POSSIBLE ONCE THE VEHICLE HAS STOPPED AND AT THE SAME TIME THE GEAR IS ENGAGED AND THE CLUTCH LEVER OPERATED.**



**OPERATING ONLY EITHER THE FRONT OR THE REAR BRAKE SIGNIFICANTLY REDUCES BRAKING POWER AND A WHEEL MAY GET BLOCKED RESULTING IN LACK OF GRIP.**

**WHEN STOPPING WHILE TRAVELLING UPHILL, CLOSE THE THROTTLE COMPLETELY AND ONLY USE THE BRAKES TO HOLD THE VEHICLE IN POSITION.**

**USING THE ENGINE TO HOLD THE VEHICLE ON A HILL MAY CAUSE THE CLUTCH TO OVERHEAT.**

**BRAKING CONTINUOUSLY WHILE GOING DOWNHILL MAY RESULT IN FRICTION GASKET OVERHEATING AND CONSEQUENTLY IN POOR BRAKING.**

**TAKE ADVANTAGE OF THE ENGINE COMPRESSION AND SHIFT UP GEARS USING THE BRAKES ALTERNATIVELY.**

**NEVER RIDE WITH THE ENGINE OFF WHEN GOING DOWNHILL.**

**WHEN RIDING ON WET SURFACES OR WITH POOR GRIP (SNOW, ICE, MUD, ETC.) RIDE AT A MODERATE SPEED AVOIDING SUDDEN BRAKING OR MANOEUVRES THAT MAY LEAD TO LACK OF GRIP AND CONSEQUENTLY TO FALLS.**

## **Parking**

It is very important to select an adequate parking spot, in compliance with road signals and the guidelines described below.

**CAUTION**

TO MOVE THE MOTORCYCLE, WITH ONE HAND GRAB THE HANDLEBAR AND WITH THE OTHER ONE THE PASSENGER HANDLE.

**CAUTION**

PARK ON SAFE AND LEVEL GROUND TO PREVENT THE VEHICLE FROM FALLING.

DO NOT LEAN THE VEHICLE AGAINST A WALL OR LAY IT ON THE GROUND.

ENSURE THAT THE VEHICLE AND, IN PARTICULAR, PARTS OF THE VEHICLE WHICH MAY BECOME HOT (ENGINE, OIL RADIATOR AND LINES, EXHAUST SYSTEM, BRAKE DISCS) ARE NOT A HAZARD TO PERSONS OR CHILDREN. DO NOT LEAVE YOUR VEHICLE UNATTENDED WITH THE ENGINE ON OR THE KEY IN THE IGNITION SWITCH.

**CAUTION**

IF THE VEHICLE FALLS OR IS ON A STEEP INCLINE FUEL CAN LEAK.

FUEL USED TO DRIVE INTERNAL COMBUSTION ENGINES IS HIGHLY FLAMMABLE AND CAN BECOME EXPLOSIVE UNDER CERTAIN CONDITIONS.



DO NOT REST THE RIDER OR PASSENGER WEIGHT ON THE SIDE STAND.

**Catalytic silencer**

The vehicle has a silencer with a "platinum - palladium - rhodium three-way" metal catalytic converter.

This device oxidises the CO (carbon monoxide) producing carbon dioxide, and the UHC (unburned hydrocarbons) producing water vapour and reduces NOx (nitrogen oxide) producing oxygen and nitrogen present in the exhaust fumes.



**DO NOT PARK THE VEHICLE NEAR DRY BRUSHWOOD OR IN PLACES EASILY ACCESSIBLE BY CHILDREN BECAUSE THE CATALYTIC CONVERTER REACHES HIGH TEMPERATURES DURING VEHICLE OPERATION; FOR THIS REASON, PAY UTMOST ATTENTION AND DO NOT TOUCH IT UNTIL IT HAS COMPLETELY COOLED DOWN.**

**NEVER USE LEADED PETROL AS THIS WILL CONTAMINATE THE CATALYTIC CONVERTER, RENDERING IT INOPERATIVE.**

Vehicle owners are warned that the law may prohibit the following:

- the removal of any device or element belonging to a new vehicle or any other action by anyone leading to render it non-operating, if not for maintenance, repair or replacement reasons, in order to control noise emission before the sale or delivery of the vehicle to the ultimate buyer or while it is used;
- using the vehicle after that device or element has been removed or rendered non-operating.

Check the muffler/exhaust silencer and the silencer pipes, make sure there are no signs of rust or holes and that the exhaust system works properly.

If you not an increase in exhaust noise, take your vehicle to an Official **Aprilia** Dealer at once.

#### **NOTE**

**DO NOT TAMPER WITH THE EXHAUST SYSTEM.**

## Stand (03\_22, 03\_23, 03\_24)



**THE SIDE AND CENTRE STANDS SHOULD TURN SMOOTHLY, GREASE THE JOINT IF NECESSARY.**

### **SIDE STAND**

If the stand has been folded up for any manoeuvre (for example, when the vehicle is in motion), place the vehicle on the stand again as follows:

- Grasp the left grip and put the right hand on the upper rear part of the vehicle.
- Push the side stand with your right foot to fully extend the stand.
- Lean the vehicle until the stand touches the ground.
- Turn the handlebar fully leftwards.

### **CAUTION**

**MAKE SURE THE VEHICLE IS STABLE.**

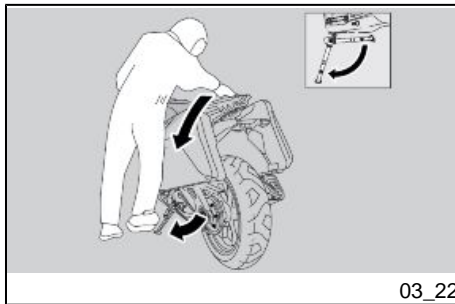

03\_22

### **CAUTION**

**CAREFULLY CLEAN THE STAND JOINT BY REMOVING THE DIRT.**

**THEN LUBRICATE THE JOINT EVERY 5000 km (31036 mi)**

**For the lubricating type to be used, refer to the recommended products table.**

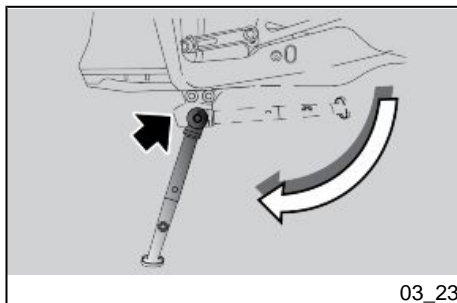

03\_23

A safety switch is installed on the side stand to inhibit ignition or to stop the engine when a gear is engaged and the side stand is lowered.

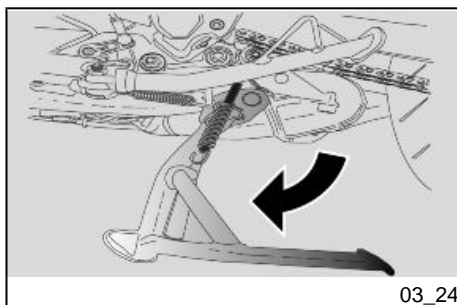

03\_24

### CENTRE STAND

(if applicable)

If the stand has been folded up for any manoeuvre (for example, when the vehicle is in motion), place the vehicle on the stand again as follows:

- Grasp the left grip and grab the passenger handle, with the right hand on the upper rear part of the vehicle.
- Push the centre stand downward with your right foot and simultaneously lift the motorcycle with your right hand and pull it back.

### CAUTION

**MAKE SURE THE VEHICLE IS STABLE.**

### Suggestion to prevent theft

#### CAUTION

**WHEN USING A DISC LOCKING DEVICE, PAY UTMOST ATTENTION TO REMOVE IT BEFORE RIDING. FAILURE TO OBSERVE THIS WARNING MAY CAUSE SERIOUS DAMAGE TO THE BRAKING SYSTEM AND ACCIDENTS WITH CONSEQUENT PHYSICAL INJURIES OR EVEN DEATH.**

NEVER leave the ignition key in the lock and always use the steering lock. Park the vehicle in a safe place such as a garage or a place with guards. Whenever possible, use an additional anti-theft device. Make sure all vehicle documents are in order and the road tax paid. Write down your personal details and telephone number on this page to help identifying the owner in case of vehicle retrieval after a theft.

LAST NAME: .....

NAME: .....

ADDRESS: .....

TELEPHONE NO.: .....

#### **WARNING**

**IN MANY CASES, STOLEN VEHICLES CAN BE IDENTIFIED BY DATA IN THE USE / MAINTENANCE BOOKLET**

### **Safe driving**

Some simple tips are provided below that will enable you to use your motorcycle on a daily basis in greater safety and peace of mind. Your skill and your mechanical knowledge are the basis of a safe ride. We recommend trying out the motorcycle in traffic-free zones to familiarise with it.

1. Before riding off, remember to put the helmet on and fasten it correctly.
2. Reduce speed on rough roads and ride with care.
3. After riding on a long stretch of wet road without using the brakes, braking can be poor at the beginning. In these conditions, it is a good idea to apply the brakes from time to time.
4. Do not brake hard on wet, unsurfaced or slippery roads.
5. Avoid riding off by mounting the scooter when it is resting on its support.

6. If the motorcycle is used on roads covered with sand, mud, snow mixed with salt, etc., clean the brake discs frequently with a mild detergent in order to prevent abrasive particles from building up inside the holes, which can result in early brake pads wear.

**CAUTION**

**ALWAYS RIDE WITHIN YOUR LIMITS. RIDING UNDER THE INFLUENCE OF ALCOHOL OR OTHER DRUGS AND CERTAIN MEDICINES IS EXTREMELY DANGEROUS.**

**CAUTION**

**ANY ELABORATION THAT MODIFIES THE VEHICLE'S PERFORMANCES, SUCH AS TAMPERING WITH ORIGINAL STRUCTURAL PARTS IS STRICTLY FORBIDDEN BY LAW, AND RENDERS THE MOTORCYCLE NO LONGER CONFORMING TO THE APPROVED TYPE AND DANGEROUS FOR RIDING.**

**CAUTION**

**DO NOT ADJUST THE MIRRORS WHILE RIDING. THIS COULD CAUSE YOU TO LOOSE CONTROL OF THE MOTORCYCLE.**

**CAUTION**

**IF RIDING THE MOTORCYCLE EQUIPPED WITH APRILIA ORIGINAL ACCESSORIES (TOP CASE AND/OR TANK BAG) MODERATE THE MAXIMUM SPEED WITHIN 160 KM/H.**

**IN THE STANDARD CONFIGURATION, THE MOTORCYCLE CAN BE RIDDEN AT A HIGHER SPEED WITHOUT THE ACCESSORIES MENTIONED ABOVE WITHIN THE LIMITS ESTABLISHED BY LAW.**

**IN CASE OF NON-ORIGINAL ACCESSORIES INSTALLED ON MOTORCYCLE, ABNORMAL LOAD, IF THE MOTORCYCLE IS NOT IN OPTIMAL GENERAL CONDITIONS, UNDER ADVERSE WEATHER CONDITIONS, THE SPEED SHOULD BE FURTHER REDUCED.**

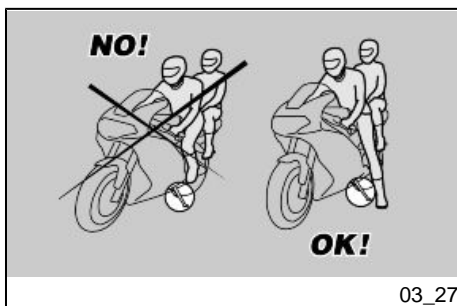
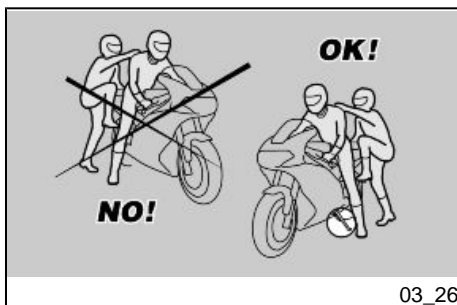
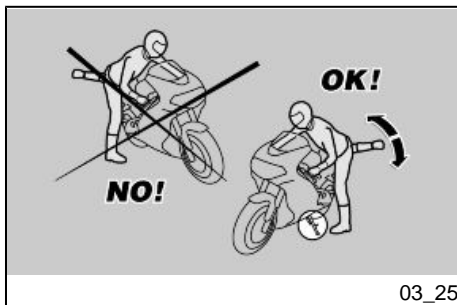

### Basic safety rules (03\_26)

The following recommendations should receive your maximum attention, because they are provided to increase your safety, and decrease damage to people, things and vehicles, in the case of a fall of the rider or passenger from the vehicle and/or from the fall or overturning of the vehicle.

Mounting and dismounting the vehicle should always be performed with total freedom of movement and with the hands free of all objects. (i.e.- objects, helmet, gloves, or glasses).

Mount and dismount only on the left side of the vehicle, and only with the side stand lowered.



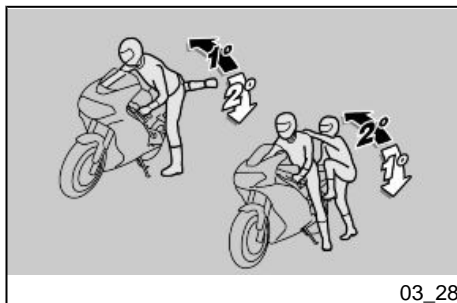

03\_28

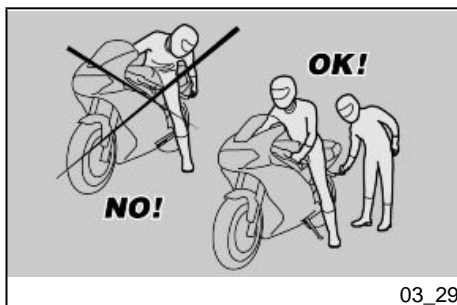

03\_29

The stand is designed to support the weight of the vehicle and a small additional weight, which does not include the rider and passenger.

Mounting into driving position, with the side stand in place, is permitted only to prevent the possibility of the vehicle falling or overturn, and does not indicate the possibility for the rider and passenger's weight to be placed on the side stand.

During mounting and dismounting the vehicle's weight can cause a loss of balance, with consequent loss of equilibrium and the possibility of falling or overturning.

#### CAUTION

**THE RIDER SHOULD ALWAYS BE THE FIRST TO MOUNT AND THE LAST TO DISMOUNT FROM THE VEHICLE, AND SHOULD CONTROL THE STABILITY AND EQUILIBRIUM OF THE VEHICLE WHILE THE PASSENGER IS MOUNTING AND DISMOUNTING**

In any case, the passenger should mount and dismount the vehicle using caution to avoid causing the vehicle or the rider to lose balance.

#### CAUTION

**THE RIDER TO INSTRUCT THE PASSENGER ABOUT THE PROPER WAY TO MOUNT AND DISMOUNT FROM THE VEHICLE.**

**THE VEHICLE INCLUDES PASSENGER FOOTRESTS WHICH SHOULD BE USED DURING MOUNTING AND DISMOUNTING. THE PASSENGER SHOULD ALWAYS USE THE LEFT FOOTREST FOR MOUNTING AND DISMOUNTING FROM THE VEHICLE.**

**DO NOT DISMOUNT OR EVEN ATTEMPT TO DISMOUNT BY JUMPING OR STRETCHING OUT YOUR LEG IN ORDER TO TOUCH THE GROUND. IN BOTH CASES THE STABILITY AND EQUILIBRIUM OF THE VEHICLE COULD BE COMPROMISED.**

#### **CAUTION**

**BAGGAGE OR OBJECTS ATTACHED TO THE REAR PART OF THE VEHICLE CAN CREATE AN OBSTACLE DURING MOUNTING AND DISMOUNTING FROM THE VEHICLE.**

**IN ALL CASES, THINK AHEAD AND MOVE YOUR RIGHT LEG CAREFULLY, AS IT WILL HAVE TO AVOID AND CLEAR THE REAR PART OF THE VEHICLE (INCLUDING BAGGAGE AND THE TAIL FAIRING) WITHOUT CAUSING LOSS OF BALANCE.**

#### **MOUNTING**

- Grip the handlebar properly and mount the vehicle without placing your weight upon the side stand.

#### **CAUTION**

**IN THE CASE THAT YOU ARE NOT ABLE TO REST BOTH FEET ON THE GROUND, PUT THE RIGHT FOOT ON THE GROUND, (IN THE CASE OF A LOSS OF BALANCE THE LEFT SIDE IS "PROTECTED" BY THE SIDE STAND) AND KEEP YOUR LEFT FOOT READY TO BE POSITIONED.**

- Place both feet on the ground and straighten the vehicle into the driving position, always maintaining its equilibrium.

**CAUTION**

**THE RIDER SHOULD NOT OPEN OR TRY TO OPEN THE PASSENGER FOOTRESTS FROM THE RIDER'S SEAT, AS IT COULD COMPROMISE THE STABILITY AND EQUILIBRIUM OF THE VEHICLE.**

- Have the passenger open the two passenger foot pegs.
- Show the passenger how to mount the vehicle.
- Use your left foot to push on the side stand and make it fully return to its position.

**DISMOUNTING**

- Select an appropriate parking spot.
- Stop the vehicle.



**MAKE SURE THAT THE GROUND ON WHICH THE MOTORCYCLE IS PARKED IS FIRM, EVEN AND FREE OF OBSTACLES.**

- Use the heel of your left foot to completely open the side stand.

**CAUTION**

**IN THE CASE THAT YOU ARE NOT ABLE TO REST BOTH FEET ON THE GROUND, PUT THE RIGHT FOOT ON THE GROUND, (IN THE CASE OF A LOSS OF BALANCE THE LEFT SIDE IS "PROTECTED" BY THE SIDE STAND) AND KEEP YOUR LEFT FOOT READY TO BE POSITIONED.**

- Place both feet on the ground and keep the vehicle balanced in the driving position.
- Show the passenger how to dismount from the vehicle.



**RISK OF FALLING OR OVERTURNING.**

**MAKE SURE THAT THE PASSENGER HAS DISMOUNTED FROM THE VEHICLE.**

**DO NOT PLACE YOUR WEIGHT UPON THE SIDE STAND.**

- Lean the motorcycle until the stand touches the ground.
- Correctly grip the handlebar, and dismount from the vehicle.
- Turn the handlebar completely to the left.
- Place the passenger footrest in its place.

**CAUTION**



**MAKE SURE THE VEHICLE IS STABLE.**

# CAPONORD 1200

**aprilia**



**Chap. 04  
Maintenance**

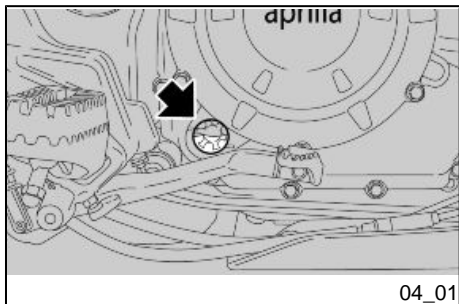

## Engine oil level check (04\_01, 04\_02, 04\_03)

Check the engine oil level frequently.

### NOTE

**CARRY OUT MAINTENANCE OPERATIONS AT HALF THE INTERVALS SPECIFIED IF THE VEHICLE IS USED IN PARTICULAR RAINY OR DUSTY CONDITIONS, OFF ROAD OR FOR TRACK USE.**



**ENGINE OIL LEVEL MUST BE CHECKED WHEN THE ENGINE IS WARM.**

**IF YOU CHECK LEVEL WHEN THE ENGINE IS COLD, OIL LEVEL COULD TEMPORARILY DROP BELOW THE "MIN" MARK.**

**THIS SHOULD NOT BE CONSIDERED A PROBLEM PROVIDED THAT THE ALARM WARNING LIGHT AND THE ENGINE OIL PRESSURE ICON DO NOT TURN ON SIMULTANEOUSLY ON THE DISPLAY.**

### CAUTION

**DO NOT LET THE ENGINE IDLE WITH THE VEHICLE AT A STANDSTILL TO WARM UP THE ENGINE AND OBTAIN THE OPERATING TEMPERATURE OF ENGINE OIL.**

**PREFERABLY CHECK THE OIL AFTER A JOURNEY OF AFTER TRAVELLING APPROXIMATELY 15 Km (10 miles) IN EXTRAURBAN CONDITIONS (ENOUGH TO WARM UP THE ENGINE OIL TO OPERATING TEMPERATURE).**

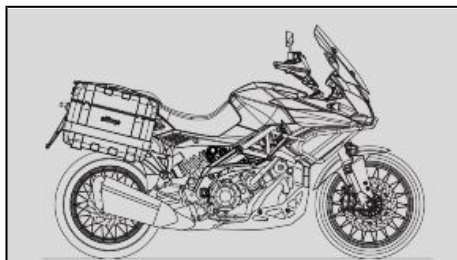

04\_02

- Switch off the engine and wait at least five minutes to allow the lubricant to drain back into the sump.
- Keep the vehicle upright on a level surface and with both wheels on the ground.
- Check the oil level from the sight glass on the clutch case.

**MAX** = maximum level.

MIN = minimum level

The difference between the "**MAX**" and "**MIN**" marks is approx. 460 cm<sup>3</sup> (28.07 cu.in).

- The oil level is correct when it is close to the "**MAX**" mark.

#### CAUTION

**THE VEHICLE MUST BE UNLOADED.**

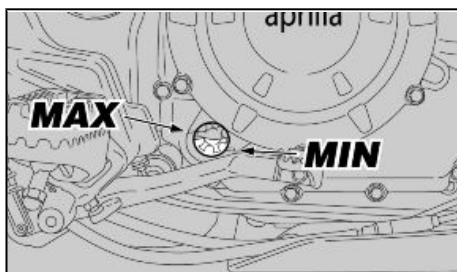

04\_03

#### Engine oil top-up (04\_04)

#### CAUTION



**DO NOT GO BEYOND THE "MAX" AND BELOW THE "MIN" LEVEL MARK TO AVOID SEVERE ENGINE DAMAGE.**

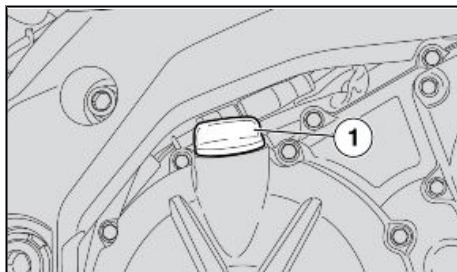

04\_04

**Fill with engine oil as required:**

- Unscrew and remove the cap (1).

**When using a funnel or any other element, make sure it is perfectly clean.**



**DO NOT ADD ADDITIVES OR OTHER SUBSTANCES TO THE OIL.**

#### **CAUTION**

**USE OIL WITH THE SPECIFICATIONS INDICATED IN THE RECOMMENDED PRODUCTS TABLE GIVEN AT THE END OF THE MANUAL.**

- Top-up the oil in the reservoir until you reach the correct level.

## **Engine oil change**

#### **CAUTION**

**THE ENGINE OIL MUST BE CHECKED AND CHANGED BY AN Official Aprilia Dealership**

## **Engine oil filter replacement**

#### **CAUTION**

**THE ENGINE OIL FILTER MUST BE CHECKED AND CHANGED BY AN Official Aprilia Dealership**



## Tyres

This vehicle is fitted with tyres without inner tubes (Tubeless).



**CHECK TYRE INFLATION PRESSURE REGULARLY, AT LEAST ONCE A MONTH, AT AMBIENT TEMPERATURE.**

**MEASUREMENTS MAY BE INCORRECT IF TYRES ARE WARM.**

**CHECK PRESSURE MAINLY BEFORE AND AFTER LONG TRIPS.**

**IF THE TYRE PRESSURE IS TOO HIGH, UNEVENNESS IN THE ROAD SURFACE WILL NOT BE DAMPED AND WILL BE TRANSMITTED TO THE HANDLEBAR, RESULTING IN AN UNPLEASANTLY HARSH RIDE AND POOR ROAD HOLDING, ESPECIALLY WHEN CORNERING.**

**AN UNDERINFLATED TYRE, ON THE OTHER HAND, WILL EXTEND THE CONTACT PATCH TO INCLUDE A LARGER PORTION OF THE TYRE SIDEWALLS. WHEN THIS IS THE CASE, THE TYRE MIGHT SLIP ON OR BECOME DETACHED FROM THE WHEEL RIM, LEADING TO LOSS OF CONTROL OVER THE VEHICLE.**

**TYRES MAY EVEN DETACH FROM THE WHEEL RIMS UNDER VERY HARD BRAKING.**

**THE VEHICLE MAY EVEN SKID IN A BEND.**

**INSPECT TREAD SURFACE AND CHECK IT FOR WEAR. BADLY WORN TYRES MAY COMPROMISE TRACTION AND HANDLING.**

**REPLACE TYRES WHEN WORN OR IF THERE IS A PUNCTURE IN THE TREAD AREA BIGGER THAN 5 mm (0.197 in).**

**BALANCE WHEELS AFTER A TYRE IS MENDED. USE ONLY TYRE SIZES INDICATED BY THE MANUFACTURER.**

**CHECK THAT THE INFLATION VALVES HAVE THEIR CAPS FITTED TO AVOID UNEXPECTED FLAT TYRES. REPLACEMENT, REPAIR, MAINTENANCE AND BALANCING OPERATIONS ARE HIGHLY IMPORTANT AND SO THEY SHOULD**

**BE CARRIED OUT USING THE SPECIFIC TOOLS AND WITH THE ADEQUATE KNOWLEDGE.**

**IT IS THEREFORE ESSENTIAL TO TAKE YOUR VEHICLE TO AN Official Aprilia Dealer OR SPECIALISED TYRE WORKSHOP TO CARRY OUT THE OPERATIONS ABOVE. NEW TYRES MAY BE COATED WITH A SLIPPERY COATING: RIDE WITH CAUTION DURING THE FIRST KILOMETRES. DO NOT APPLY UNSUITABLE LIQUIDS ON TYRES. WHEN TYRES ARE OLD, THE MATERIAL MAY HARDEN AND NOT PROVIDE ADEQUATE ROAD HOLDING, EVEN IF TYRES ARE STILL WITHIN THE WEAR LIMIT.**

**SHOULD THIS OCCUR, REPLACE THE TYRES.**

**Minimum tread depth:**

front and rear 2 mm (0.079 in) (USA 3 mm - 0.118 in) or more if so required by applicable legislation in the country where the vehicle is used.

## **Spark plug dismantlement**

### **CAUTION**

**TO REMOVE, CHECK, CLEAN AND REPLACE THE SPARK PLUGS, CONTACT AN Official aprilia Dealer**

## **Removing the air filter**

### **CAUTION**

**TO REMOVE, CHECK AND REPLACE THE AIR FILTER, CONTACT AN Official aprilia Dealer**

## Cooling fluid level (04\_05, 04\_06)



**DO NOT USE YOUR MOTORCYCLE IF THE COOLANT LEVEL IS BELOW THE MINIMUM LEVEL MARKED «MIN».**

### CAUTION



**COOLANT IS TOXIC IF INGESTED; CONTACT WITH YOUR EYES OR SKIN MAY CAUSE IRRITATION. IF THE FLUID GETS IN CONTACT WITH THE EYES OR SKIN, RINSE REPEATEDLY WITH PLENTY OF WATER AND SEEK MEDICAL ADVICE. IF SWALLOWED, INDUCE VOMITING, RINSE MOUTH AND THROAT WITH PLENTY OF WATER AND SEEK MEDICAL ADVICE IMMEDIATELY.**

### CAUTION



**TAKE CARE NOT TO POUR COOLANT ONTO HOT ENGINE OR EXHAUST SYSTEM COMPONENTS; THE FLUID MAY CATCH FIRE AND BURN WITH INVISIBLE FLAMES. WHEN CARRYING OUT MAINTENANCE OPERATIONS, IT IS ADVISABLE TO WEAR LATEX GLOVES. CONTACT AN Official APRILIA Dealer FOR REPLACEMENT.**

**DO NOT DISPOSE OF THE FLUID INTO THE ENVIRONMENT.**

**KEEP OUT OF THE REACH OF CHILDREN**

**DO NOT REMOVE THE COVER OF THE EXPANSION TANK (1) WHEN THE ENGINE IS HOT AS THE COOLANT IS UNDER PRESSURE AND AT A HIGH TEMPERATURE. CONTACT WITH SKIN OR CLOTHES MAY CAUSE SERIOUS BURNS AND/OR INJURIES.**

**NOTE**

**TAKE YOUR VEHICLE TO AN Official APRILIA Dealer TO HAVE THE COOLANT CHANGED.**

**WARNING**

**WAIT FOR THE ENGINE TO COOL DOWN BEFORE CHECKING OR TOPPING-UP THE COOLANT LEVEL.**

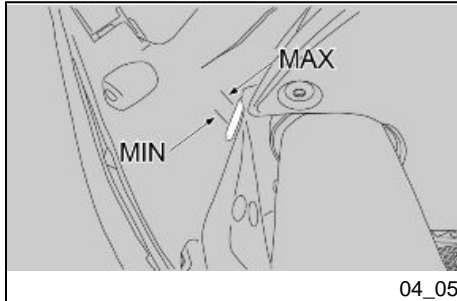
**CHECK AND TOPPING-UP**

- Shut off the engine and wait until it cools off.
- Keep the vehicle upright and with the two wheels on the ground.
- Turn the handlebar to the left, keeping the vehicle upright.
- Make sure that the coolant level in the expansion tank is between the **"MAX"** (**"MAX"**= maximum level) and **"MIN"** (**"MIN"**= minimum level) reference marks

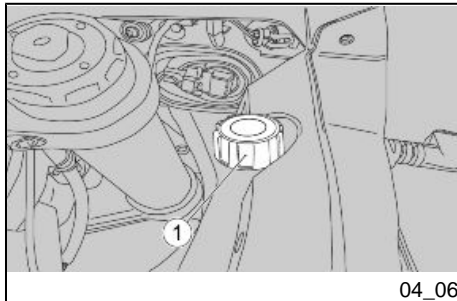
**Otherwise:**

- Remove the filler cap (1).
- Top-up with recommended coolant until the coolant level is near the **"MAX"** reference mark. Do not exceed this level or the coolant will spill out when the engine is turning.
- Refit and lock the filler cap (1).

**CAUTION**

**IN THE EVENT OF COOLANT CONSUMPTION OR IF THE RESERVOIR IS EMPTY, CHECK FOR LEAKS IN THE CIRCUIT.**

**Checking the brake oil level (04\_07, 04\_08)**

For the front brake:

- rest the vehicle on its stand and turn the handlebar so that the fluid in the reservoir is parallel to the reservoir edge.
- Check that the fluid in the reservoir is above the "**MIN**" reference mark.

For the rear brake:

- keep the vehicle upright and check that the fluid in the reservoir is parallel to the reservoir edge.
- Make sure that the fluid level in the reservoir is above the "**MIN**" reference mark:

Top-up if the fluid does not reach at least the "**MIN**" reference mark.

- Check brake pads and disc for wear
- If the pads and/or the disc do not need replacing, top up the fluid.

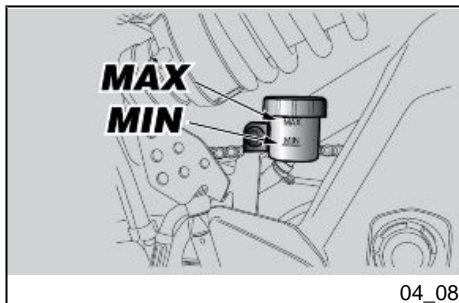
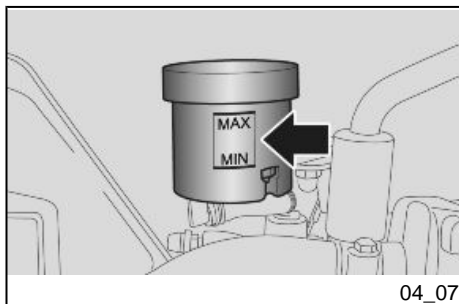

## Braking system fluid top up

### CAUTION



**FOR THE TOP-UP OF THE BRAKING SYSTEMS COOLANT, CONTACT AN Official Aprilia Dealer.**



## Checking clutch fluid (04\_09)

- Rest the vehicle on its stand.
- Turn the handlebar so that the fluid in the reservoir is parallel to the reservoir edge.
- Make sure that the fluid level in the reservoir is above the "MIN" reference mark:

Top-up if the fluid does not reach at least the "MIN" reference mark.

## Topping up clutch fluid

### CAUTION

**FOR THE TOP-UP OF THE CLUTCH FLUID, CONTACT AN Official Aprilia Dealer**

**Battery removal (04\_10, 04\_11, 04\_12)**

- Make sure that the ignition switch is set to "OFF";
- Remove the saddle.
- Remove the tool kit;
- Remove the fixing screw (1) of the rider saddle;

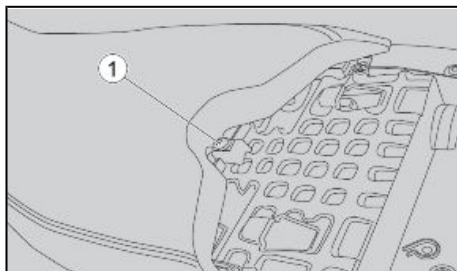

04\_10

- Undo the screws (2) and remove the cover (3);

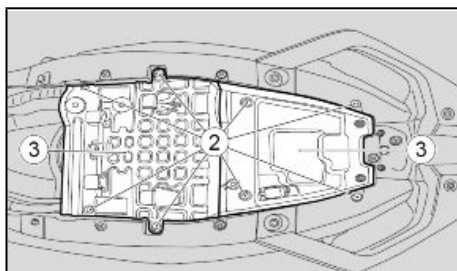

04\_11

- Slightly lift the battery
- Unscrew and remove the screw (3) from the negative terminal clamp (-);
- Move the negative lead (4) aside;
- Unscrew and remove the screw (5) of the positive terminal (+);
- Move the positive lead (6) aside;
- Remove the battery

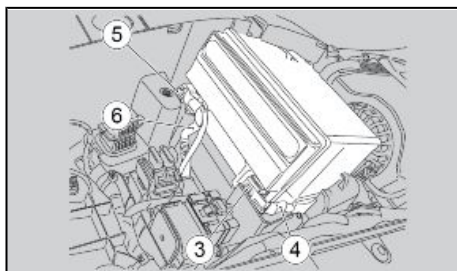

04\_12

**CAUTION**

**WHEN REFITTING THE BATTERY, MAKE SURE IT IS CORRECTLY POSITIONED AND POLES ARE NOT INVERTED.**

**CAUTION**

**UPON REFITTING, CONNECT THE LEAD TO THE POSITIVE TERMINAL (+) FIRST AND AFTERWARDS THE LEAD TO THE NEGATIVE TERMINAL (-).**



**CHECK THAT THE BATTERY LEADS AND TERMINALS ARE:**

- **IN GOOD CONDITION (NOT CORRODED OR COVERED BY DEPOSITS);**
- **COVERED BY NEUTRAL GREASE OR PETROLEUM JELLY.**

**Checking the electrolyte level****WARNING**

**THIS VEHICLE IS FITTED WITH A MAINTENANCE-FREE BATTERY AND DOES NOT NEED ANY INTERVENTION, EXCEPT FOR SPORADIC CHECKS AND RECHARGE.**

**Charging the battery**

- Remove the battery.
- Get an adequate battery charger.
- Set the battery charger for the recharge type indicated.
- Connect the battery to the battery charger.



**CAUTION**

**WHEN RECHARGING OR USING THE BATTERY, BE CAREFUL TO HAVE THE ROOM ADEQUATELY AIRED. DO NOT BREATHE GASES RELEASED WHEN THE BATTERY IS RECHARGING.**

Switch on the battery charger.

**Characteristic****Recharge modes**

Recharge - Ordinary

Electric Current - 1.0 A

Time - 8-10 hours

Recharge - Fast

Electric Current - 6 A

Time - 1 hour

**Long periods of inactivity**

**IF THE VEHICLE IS OUT OF USE FOR MORE THAN TWENTY DAYS, DISCONNECT THE 30 A FUSE TO PREVENT BATTERY DETERIORATION CAUSED BY CURRENT CONSUMPTION BY THE MULTIFUNCTION COMPUTER.**

**CAUTION**

**REMOVING THE 30 A FUSES RESETS THESE FUNCTIONS: DIGITAL CLOCK, TRIP INFORMATION AND CHRONOMETER TIMES.**

If the vehicle is inactive longer than fifteen days, it is necessary to recharge the battery to avoid sulphation.

- Remove the battery.

In winter or when the vehicle is out of use for prolonged periods, check charge level frequently (about once a month) to prevent deterioration.

- Recharge it fully with an ordinary charge.

If the battery is still on the vehicle, disconnect the cables from the terminals.

**NOTE**

**THE FIRST TIME THE ENGINE IS STARTED AFTER RECONNECTING THE BATTERY LEADS, WAIT 20 SECONDS BETWEEN THE MOMENT THE KEY IS SET TO "KEY ON" AND THE MOMENT THE STARTER BUTTON CAN BE PUSHED.**

**THE ENGINE WILL NOT START IF START-UP IS ATTEMPTED BEFORE THE PRE-SET 20 SECONDS ELAPSE.**

**Fuses (04\_13, 04\_14, 04\_15, 04\_16)**

Check all the fuses in case of failure or irregular functioning of an electrical component or engine starting failure.

**CAUTION**

**DO NOT REPAIR FAULTY FUSES.**

**NEVER USE A FUSE THAT IS DIFFERENT THAN WHAT IS SPECIFIED TO PREVENT DAMAGES TO THE ELECTRICAL SYSTEM OR SHORT CIRCUITS, AND THE RISK OF FIRE.**

**CAUTION**

**A FUSE THAT BLOWS FREQUENTLY MAY INDICATE A SHORT CIRCUIT OR OVERLOAD. IF THIS OCCURS, CONSULT AN APRILIA Official Dealer.**

To check:

- Set the ignition switch to "OFF" to avoid an accidental short circuit.
- Open the cover of the secondary fuse box on the front left.
- Take out one fuse at a time and check if the filament is broken.
- Before replacing the fuse, find and solve, whenever possible, the problem that caused it to blow.
- If the fuse is damaged, replace it with one of the same current rating.
- To check the main fuses, located under the cover in the compartment beneath the saddle, carry out the same operations described above for the secondary fuses.

**NOTE**

**IF THE SPARE FUSE IS USED, REPLACE WITH ONE OF THE SAME TYPE IN THE CORRESPONDING FITTING.**

**CAUTION**

**REMOVING THE 30 A FUSES RESETS THESE FUNCTIONS: DIGITAL CLOCK, TRIP INFORMATION AND CHRONOMETER TIMES.**

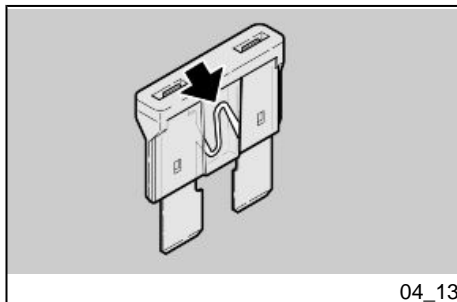

04\_13

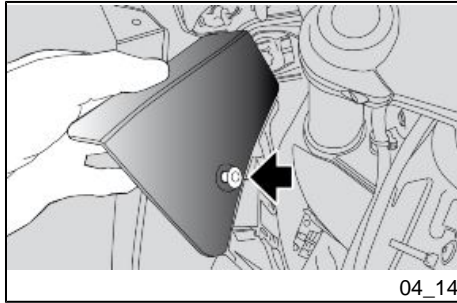

- To access the secondary fuse box, remove the fixing clip of the flap on the left inner side of the dashboard.
- Remove the flap.

#### **SECONDARY FUSES (front left side, above the water radiator) (Caponord 1200)**

1 A - Recovery logic relay (safety), Stop, Horn, Daylight running light, License plate light (10 A).

2 - Instrument panel power supply, anti-theft power supply (if installed), EVC power supply, arrangement + bludeash key (7.5 A).

3 - ECU positive live (15 A).

4 - Permanent ECU positive (7.5 A).

5 - Coils, injectors, petrol pump (15 A).

6 - Low beam/high beam light power, relay lights (15 A).

7 - Fans (15 A).

#### **NOTE**

**THREE FUSES (8) ARE SPARE FUSES**

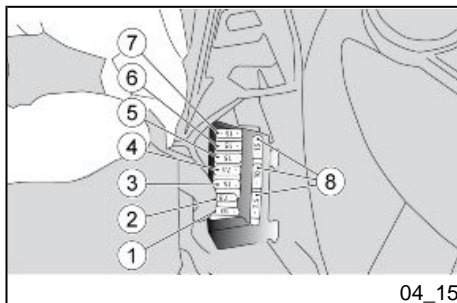

04\_15

### SECONDARY FUSES (front left side, above the water radiator) (Caponord 1200 Travel Pack)

1 A - Recovery logic relay (safety), Stop, Horn, Daylight running light, License plate light (10 A).

2 - Instrument panel power supply, anti-theft power supply (if installed), VCU power supply, arrangement + bludeash key (7.5 A).

3 - ECU positive live (15 A).

4 - Permanent ECU positive (7.5 A).

5 - Coils, injectors, petrol pump (15 A).

6 - Low beam/high beam light power, relay lights (15 A).

7 - Fans (15 A).

### NOTE

**THREE FUSES (8) ARE SPARE FUSES**

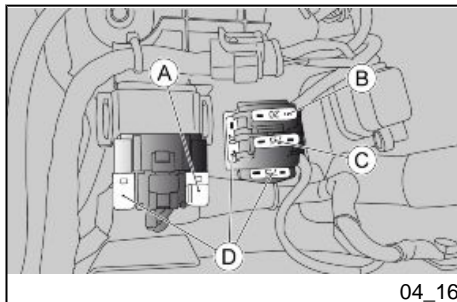

04\_16

### MAIN FUSES - (under the saddle, remove the battery protection)

A - Battery recharge, primary injection relay, key, arrangement + permanent bluedash (30 A)

B - Permanent ECU ABS positive (20 A).

C - Electrical socket, heated handgrips (if installed), anti-theft, GPS power supply (7.5 A)

#### **NOTE**

**THREE FUSES (D) ARE SPARE FUSES**

## **Lamps**

#### **CAUTION**



**BEFORE REPLACING A BULB, TURN THE IGNITION SWITCH TO «KEY OFF» AND WAIT A FEW MINUTES FOR THE BULB TO COOL OFF.**

**WEAR CLEAN GLOVES OR USE A CLEAN DRY CLOTH TO REPLACE THE BULB.**

**DO NOT LEAVE PRINTS ON THE BULB AS THIS MAY CAUSE IT TO OVERHEAT OR EVEN BLOW OUT. IF YOU TOUCH THE BULB WITHOUT WEARING GLOVES, CLEAN OFF PRINTS WITH ALCOHOL TO AVOID DAMAGING THE BULB.**

**DO NOT FORCE ELECTRICAL CABLES.**

#### **BULB LAYOUT**

In the headlamp there are:

- two tail light bulbs (side)
- two low beam light bulbs (side);
- a high beam light bulb (central);

In the taillight there are:

- 10 LED

## Low/High beam lamp replacement (04\_17, 04\_18)

### REPLACEMENT OF LOW BEAM BULB

- Rest the vehicle on its stand.
- Disconnect the connector (1)

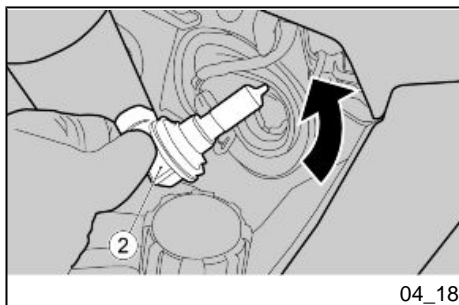
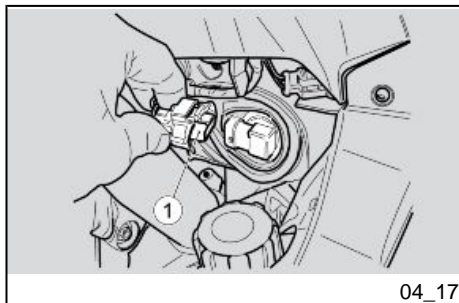

- Turn the bulb holder (2) anticlockwise and remove it;
- Replace the bulb

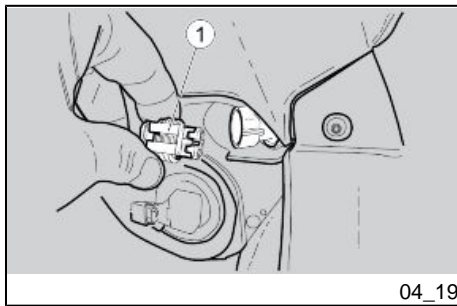

## Position light replacement (04\_19, 04\_20)

### Replacement of the Daylight running light bulb

- Rest the vehicle on its stand.
- Disconnect the connector (1)

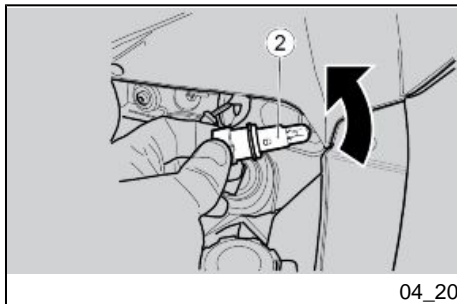

- Turn the bulb holder (2) anticlockwise and remove it;
- Replace the bulb

## Front light group

### NOTE

IN CASE OF MOTORCYCLE WASH OR IN CASE OF BOUNCING VARIATIONS, THE FRONT PROJECTOR MIGHT MIST UP. THE BEHAVIOUR IS TOTALLY NORMAL AND THE CONDENSED WATER WILL QUICKLY DISAPPEAR BY USING THE LOW BEAM AND HIGH BEAM FUNCTION



## Headlight adjustment (04\_21, 04\_22, 04\_23, 04\_24)

### NOTE

**IN COMPLIANCE WITH LOCAL LEGISLATION, SPECIFIC PROCEDURES MUST BE FOLLOWED WHEN ALIGNING THE LIGHTS.**

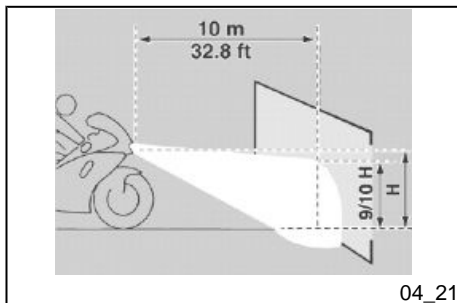

To quickly and easily check the alignment of the front light, place the vehicle on a level surface 10 m (32.8 ft) away from a vertical wall. Turn on the dipped beam light, sit on the vehicle and check that the light beam projected onto the wall is a little below the level of the headlight (about 9/10 of the total height).

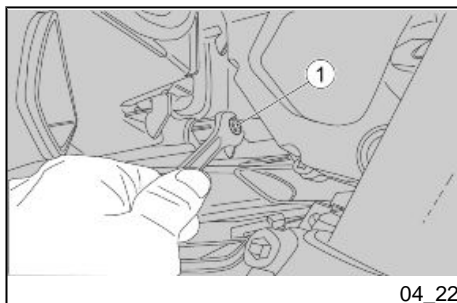

### To carry out vertical adjustment of the light beam:

- Working from the side, operate on the specific hex-head screw (1). SCREW it (clockwise) to move the light beam up; UNDO it (anticlockwise) to move the light beam down.

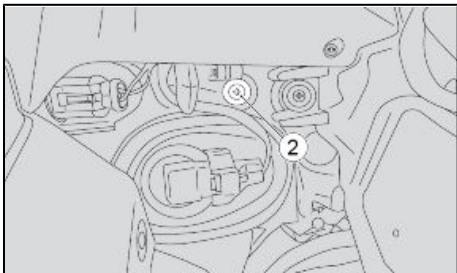

04\_23

#### In order to carry out horizontal adjustment of the light beam:

- Rest the vehicle on its stand.
- Working from the rear side of the top fairing, use a short cross screwdriver simultaneously on both screws:

- Tightening the right hand screw (3) while simultaneously loosening the left hand screw (2), the light beam moves to the left.

- Tightening the left hand screw (2) while simultaneously loosening the right hand screw (3), the light beam moves to the right.

#### NOTE

**CHECK THAT THE LIGHT BEAM HORIZONTAL DIRECTION IS CORRECT.**

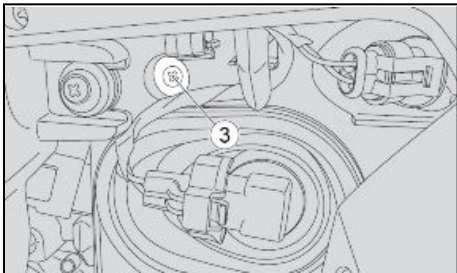

04\_24

## Front direction indicators (04\_25)

- Rest the vehicle on its stand.
- Loosen and remove screw (1).
- Remove glass (2).
- Press bulb (3) slightly and turn it anticlockwise.
- Pull the bulb (3) out of its fitting.
- Insert a bulb of the same type adequately.

### WARNING

**IF THE HEADLIGHT (4) PROTRUDES FROM ITS FITTING, INSERT IT AGAIN PROPERLY.**

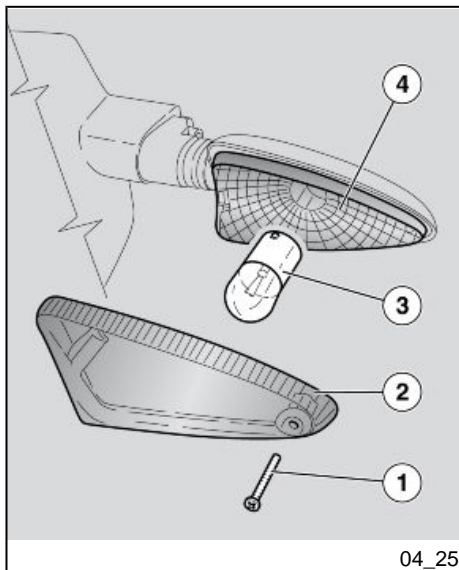

## Additional light (04\_26)

### ADJUSTMENT

- Tighten the screw (1) to move the light beam to the right and unscrew it to move it to the left
- Loosen the screw (2), adjust the light beam vertically and tighten the screw

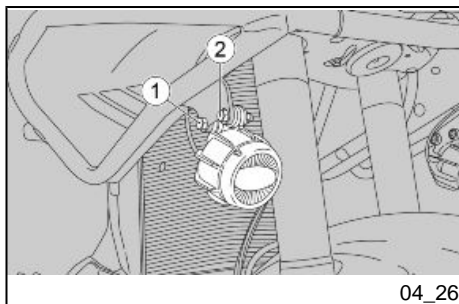

## Rear optical unit

### CAUTION

**THE REAR TAILLIGHT ASSEMBLY MUST BE CHECKED AND CHANGED BY AN Official Aprilia Dealership.**

### Rear turn indicators (04\_27)

- Rest the vehicle on its stand.
- Loosen and remove screw (1).
- Remove glass (2).
- Press bulb (3) slightly and turn it anticlockwise.
- Pull the bulb (3) out of its fitting.
- Insert a bulb of the same type adequately.

### WARNING

**IF THE HEADLIGHT (4) PROTRUDES FROM ITS FITTING, INSERT IT AGAIN PROPERLY.**

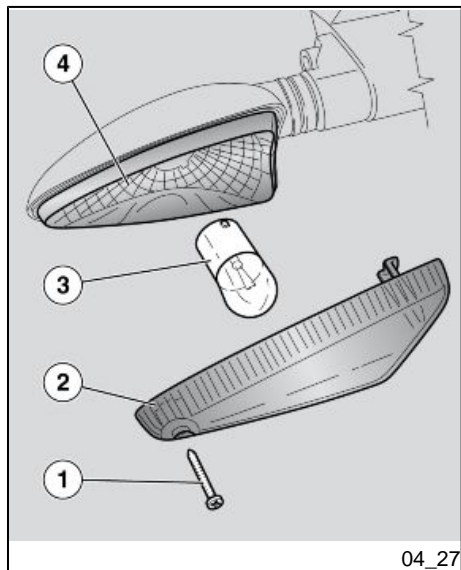

**Number plate light (04\_28, 04\_29)**

- Remove the bulb holder fixing screw (1)

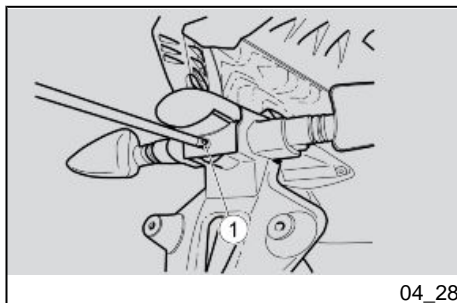

- Remove the bulb (3) from the bulb holder (2).
- Insert a bulb of the same type adequately.

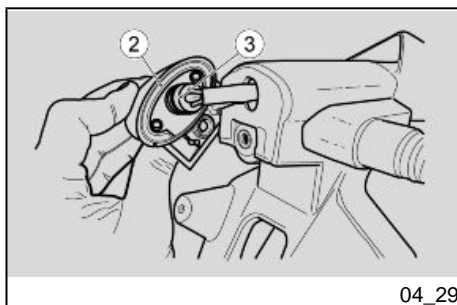
**Rear-view mirrors (04\_30, 04\_31)**

- Park the vehicle on its centre stand on safe and level ground.
- Move the protection casing (1).



**HOLD THE REAR-VIEW MIRROR (4) TO AVOID DROPPING IT BY ACCIDENT.**

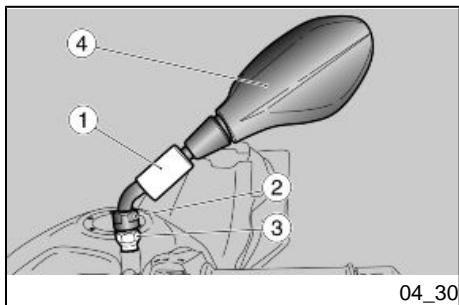

- Keep the screw (2) blocked and completely unscrew the nut (3).



**HANDLE PLASTIC AND PAINTED COMPONENTS WITH CARE, DO NOT SCRATCH OR SPOIL THEM.**

- Remove the rear-view mirror (4).

#### CAUTION

**REPEAT THE PROCEDURE TO REMOVE THE OTHER MIRROR.**



**AFTER REFITTING, ADJUST THE REAR-VIEW MIRRORS CORRECTLY AND TIGHTEN THE NUTS IN ORDER TO ENSURE STABILITY.**

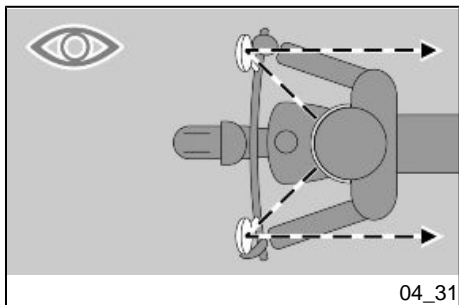

**After refitting:**

- Adjust the rear-view mirror angle correctly.

## Front and rear disc brake (04\_32, 04\_33)



**THOROUGHLY DRY THE BRAKE DISCS WHEN YOU HAVE FINISHED CLEANING TO AVOID THE PADS STICKING TO THE DISCS.**

### CAUTION



**CHECK THE BRAKE PAD WEAR BEFORE EACH TRIP AND EVERY 5000 km (3106 mi).**

#### To perform a quick pad wear check:

- Rest the vehicle on its stand.
- Carry out a visual inspection of brake disc and pads as follows:
  - at the front, for the front brake callipers;
  - on the right side of the vehicle, look from above downwards, for the rear brake calliper.

### CAUTION

**EXCESSIVE WEAR OF THE FRICTION MATERIAL MAKES THE PAD METAL SUPPORT GET INTO CONTACT WITH THE DISC, WHICH RESULTS IN A METALLIC NOISE AND SPARKS IN THE CALLIPER; THEREFORE, BRAKING EFFICIENCY AND DISC SAFETY AND INTEGRITY ARE AT RISK.**

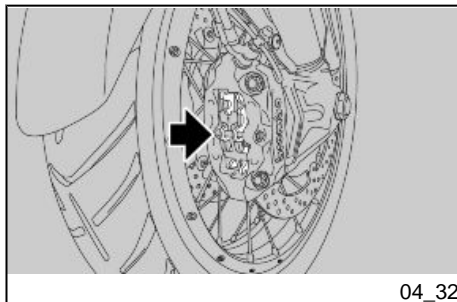

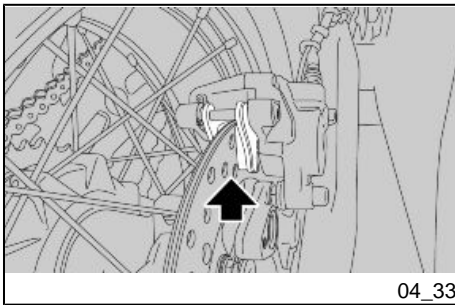

04\_33

If the friction material thickness (even of one front or rear pad) is reduced to a value of about **1.5 mm (0.06 in)** (or even if one of the wear indicators is not very visible), contact an Official **Aprilia** Dealer to have all the calliper pads replaced.

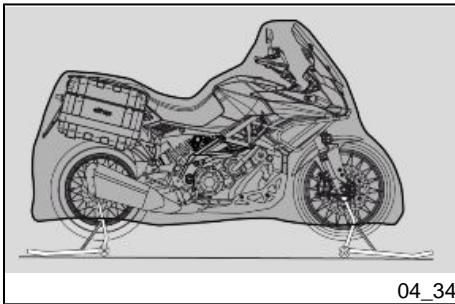

04\_34

### Periods of inactivity (04\_34)

Take some measures to avoid the side effects of not using the scooter. Besides, it is necessary to carry out general repairs and checks before garaging the motorcycle as one can forget to do so afterwards.

Proceed as follows:

- Remove the battery.
- Wash and dry the vehicle.
- Polish the painted surfaces.
- Inflate the tyres.
- Set the vehicle in a room with no heating or humidity, with minimum temperature variations and not exposed to sun rays.
- Wrap and tie a plastic bag around the exhaust pipe opening to keep moisture out.



**NOTE**

**PLACE A SUITABLE SUPPORT UNDER THE VEHICLE TO KEEP BOTH WHEELS OFF THE GROUND.**

- Put the vehicle on the front stand (optional) and on the back stand (optional).
- Cover the vehicle (do not use plastic or waterproof materials).

**AFTER STORAGE****NOTE**

**PULL OUT THE PLASTIC BAG FROM THE PIPE OPENING.**

- Uncover and clean the vehicle.
- Check the battery for correct charge and install it.
- Refill the fuel tank.
- Carry out the pre-ride checks.

**CAUTION**

**AS A TEST, RIDE THE MOTORCYCLE FOR A FEW KILOMETRES AT A MODERATE SPEED AND AWAY FROM TRAFFIC AREAS.**

**Cleaning the vehicle (04\_35, 04\_36, 04\_37)**

**Clean the motorcycle frequently if exposed to adverse conditions, such as:**

- Air pollution (cities and industrial areas).
- Salinity and humidity in the atmosphere (seashore areas, hot and wet weather).

- Special environmental/seasonal conditions (use of salt, anti-icing chemical products on the roads in winter).
- Always clean off any smog and pollution residue, tar stains, insects, bird droppings, etc. from the bodywork.
- Avoid parking the vehicle under trees. In some seasons, as from the trees may fall residues, resins, fruits or leaves that contain chemicals which are harmful to the paintwork.

**CAUTION**

**BEFORE WASHING THE VEHICLE, COVER THE ENGINE AIR INTAKES AND THE EXHAUST PIPES.**

**CAUTION**

**CLEAN THE INSTRUMENT PANEL WITH A SOFT CLOTH MOISTENED WITH WATER.**

**CAUTION**

**BEFORE WASHING THE WINDSCREEN, SOFTEN THE DIRT WITH WATER. THEN CLEAN THE INSTRUMENT PANEL WITH A SOFT CLOTH MOISTENED WITH WATER.**

**CAUTION**

**AFTER CLEANING YOUR MOTORCYCLE, BRAKING EFFICIENCY MAY BE TEMPORARILY AFFECTED DUE TO THE PRESENCE OF WATER ON THE FRICTION SURFACES OF THE BRAKING CIRCUIT. ALLOW LONGER BRAKING DISTAN-**

**CES TO PREVENT ACCIDENTS. BRAKE REPEATEDLY TO RESTORE NORMAL OPERATION. CARRY OUT THE PRE-RIDE CHECKS.**

To remove dirt and mud accumulated on painted surfaces, wet the soiled areas thoroughly with a low-pressure water jet, then remove dirt and mud with a soft car body sponge soaked abundantly in a solution of car body shampoo in water (2 - 4% shampoo dissolved in water). Then rinse with plenty of water, and dry with a chamois leather. To clean the engine outer parts, use degreasing detergent, brushes and old cloths. Wash anodised or painted aluminium parts with neutral soap and water. Using aggressive detergents may damage the surface treatment of these components.



**TO CLEAN THE HEADLIGHTS USE A SPONGE SOAKED IN WATER AND MILD DETERGENT, RUBBING THE SURFACE GENTLY AND RINSING FREQUENTLY WITH PLENTY OF WATER. REMEMBER TO CLEAN THE VEHICLE CAREFULLY BEFORE APPLYING SILICON WAX POLISH. DO NOT POLISH MATT-PAINTED SURFACES WITH POLISHING PASTE. THE VEHICLE SHOULD NEVER BE WASHED IN DIRECT SUNLIGHT, ESPECIALLY DURING SUMMER, OR WITH THE BODYWORK STILL HOT AS THE CAR SHAMPOO CAN DAMAGE THE PAINT-WORK IF IT DRIES BEFORE BEING RINSED OFF.**

#### **CAUTION**

**NEVER USE CLOTHS SOAKED IN PETROL, DIESEL OIL OR KEROSENE FOR CLEANING THE PAINTED OR PLASTIC SURFACES SO AS NOT TO DAMAGE THE LUSTRE FINISH OR ALTER THE MECHANICAL PROPERTIES.**

#### **CAUTION**



**DO NOT USE WATER (OR LIQUIDS) AT TEMPERATURES OVER 40°C (104°F) WHEN CLEANING THE VEHICLE PLASTIC PARTS. DO NOT AIM HIGH PRESSURE AIR/WATER JETS OR STEAM JETS DIRECTLY ON THESE COMPO-**

**NENTS. DO NOT USE ALCOHOL OR SOLVENTS TO CLEAN ANY RUBBER OR PLASTIC SADDLE COMPONENTS: USE WATER AND MILD SOAP.**

**CAUTION**

**DO NOT USE SOLVENTS OR PETROL BY-PRODUCTS (ACETONE, TRICHLOROETHYLENE, TURPENTINE, PETROL, THINNERS) TO CLEAN THE SADDLE. USE INSTEAD DETERGENTS WITH SURFACE ACTIVE AGENTS NOT EXCEEDING 5% (NEUTRAL SOAP, DEGREASING DETERGENTS OR ALCOHOL).**

**DRY THE SADDLE WELL AFTER CLEANING.**

**CAUTION**



**DO NOT APPLY PROTECTIVE WAX ON THE SADDLE AS IT MAY BECOME SLIPPERY.**



**WHEN USING A HIGH PRESSURE CLEANING SYSTEM (AFTER ENSURING THAT THE DETERGENT USED IS COMPATIBLE WITH THE MOTORCYCLE FINISH), MAINTAIN A DISTANCE OF AT LEAST HALF A METRE BETWEEN THE NOZZLE AND THE SURFACE BEING CLEANED.**

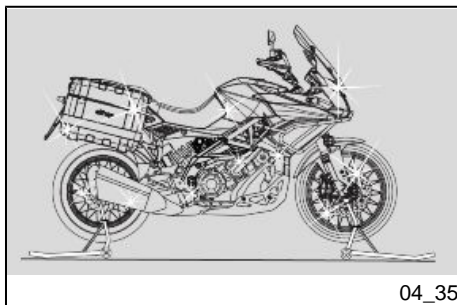

04\_35

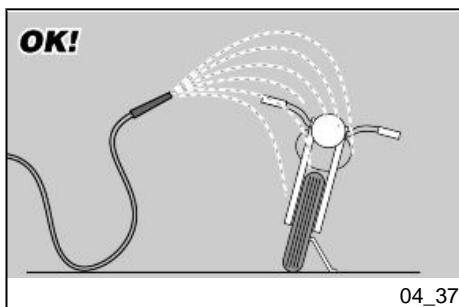
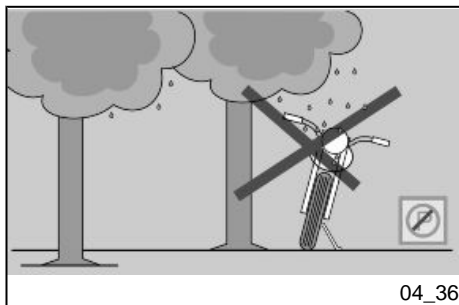

**CLEAN THE VEHICLE IMMEDIATELY WITH COLD WATER AFTER RIDING ON A ROAD TREATED WITH SALT: SALT IS HIGHLY CORROSIVE.**

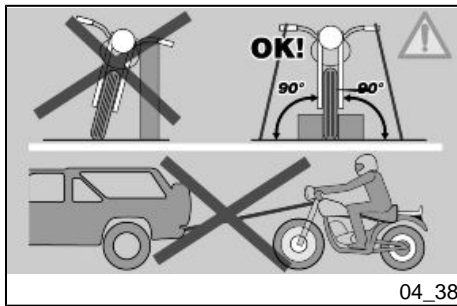

04\_38

## Transport (04\_38)

### NOTE



**BEFORE TRANSPORTING THE VEHICLE, IT IS NECESSARY TO EMPTY THE FUEL TANK AND THE CARBURETTOR ADEQUATELY, CHECKING THAT THEY ARE DRY.**

**DURING TRANSPORT, THE VEHICLE SHOULD BE UPRIGHT AND SECURELY ANCHORED AND SHOULD HAVE THE FIRST GEAR ENGAGED SO AS TO AVOID POSSIBLE FUEL, OIL OR COOLANT LEAKS.**

**IN CASE OF FAILURE, DO NOT TOW THE VEHICLE BUT CONTACT A ROAD ASSISTANCE SERVICE INSTEAD TO HAVE THE INFLAMMABLE FLUIDS DRAINED .**

## Transmission chain



**DO NOT ALTER THE FINAL DRIVE RATIO 17/42 OR THE NUMBER OF CHAIN LINKS (112).**

## Characteristic

**Final drive gear ratio**

17/42

**Type**

Endless (without master link) and with sealed links. No. of links 112

## Chain backlash check (04\_39)

### To check the clearance:

- Shut off the engine.
- Rest the vehicle on its stand.
- Engage neutral gear.
- Check that the vertical oscillation at a point between the pinion and the crown on the lower branch of the chain is approx. **25 - 30 mm (0.98 - 1.18 in)**.
- Move the vehicle forward so as to check the chain vertical oscillation in other positions too. clearance should remain constant at all wheel rotation phases.

If clearance is uniform but over **30 mm (1.18 in)** or below **25 mm (0.98 in)**, adjustment is necessary.

### CAUTION

**IF CLEARANCE IS GREATER AT SOME POSITIONS, THIS MEANS THAT SOME CHAIN LINKS ARE FLATTENED OR JAMMED.**

**TO AVOID RISK OF SEIZURE, LUBRICATE THE CHAIN ON A REGULAR BASIS.**

## Chain backlash adjustment



**FOR ANY KIND OF OPERATION TO BE PERFORMED ON THE DRIVE CHAIN, CONTACT AN Official Aprilia Dealer.**

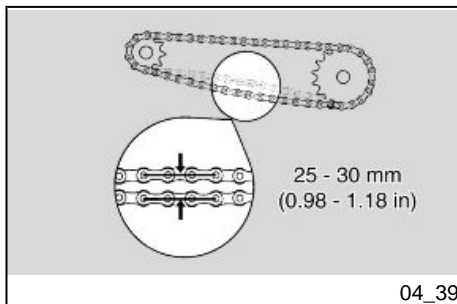

## Checking wear of chain, front and rear sprockets

Also check the following parts and make sure that the chain, pinion and sprocket do not have:

- Damaged rollers.
- Loosened pins.
- Dry, rusty, flattened or jammed chain links.
- Excessive wear.
- Missing sealing rings.
- Excessively worn or damaged pinion or sprocket teeth.

### CAUTION

**IF THE CHAIN ROLLERS ARE DAMAGED, THE PINS ARE LOOSENED AND/OR THE SEAL RINGS ARE MISSING OR DAMAGED, THE WHOLE CHAIN APPARATUS (PINION, SPROCKET AND CHAIN) SHOULD BE REPLACED.**

## Chain lubrication and cleaning

Never wash the chain with high pressure air/water jets or steam jets or highly flammable solvents.

- Wash the chain with fuel oil or kerosene. Maintenance operations should be more frequent if there are signs of quick rust.

Lubricate the chain whenever necessary.

- After washing and drying the chain, lubricate it with spray grease for sealed chains.

### CAUTION

**LUBRICATE THE CHAIN ON A REGULAR BASIS IF YOU ARE RIDING IN THE RAIN, ON WET ROADS, AFTER THE VEHICLE HAS BEEN WASHED OR IF YOU FIND DRY OR RUSTY PARTS. FLATTENED OR JAMMED CHAIN LINKS SHOULD BE LUBRICATED AND GOOD OPERATING CONDITIONS RESTORED. IF REPAIR IS NOT POSSIBLE, CONTACT AN Official Aprilia Dealer TO HAVE IT REPLACED.**



For the type of grease to be used, refer to the recommended products table.



**THE TRANSMISSION CHAIN HAS RUBBER O-RINGS BETWEEN THE SIDE PLATES OF THE CHAIN ITSELF THAT ARE USED TO HOLD THE GREASE. UTMOST ATTENTION IS REQUIRED WHEN ADJUSTING, LUBRICATING, WASHING OR REPLACING THE CHAIN.**

**CHAIN LUBRICANTS AVAILABLE ON THE MARKET CAN CONTAIN SUBSTANCES THAT DAMAGE THE CHAIN'S RUBBER O-RINGS.**

**NEVER USE THE VEHICLE JUST AFTER LUBRICATING THE CHAIN, AS THE LUBRICANT WOULD BE SPRAYED OUTWARD AND SPREAD OUT IN THE SURROUNDING AREA.**



# CAPONORD 1200

**aprilia**



**Chap. 05**  
**Technical data**

## **SIZES**

Max. length (Caponord 1200/ Caponord 1200 Travel Pack)	2245 mm (88.38 in)
Max. length(Caponord 1200 Rally)	2280 mm (89.76 in)
Max. width (at hand guards)	1000 mm (39.37 in)
Max. height (fully extracted windshield)	1440 mm (56.69 in)
Saddle height	870 mm (34.25 in)
Centre to centre distance (Caponord 1200/Caponord 1200 Travel Pack)	1,555 mm (61.22 in)
Centre to centre distance (Caponord 1200 Rally)	1575 mm (62.01 in)
Kerb weight (Caponord 1200)	251 kg (553.36 lb)
Kerb weight (Caponord 1200 Travel Pack)	265 kg (584.22 lb)
Kerb weight (Caponord 1200 Rally)	275 kg (606.27 lb)
Dry weight (without fuel) (Caponord 1200)	233 kg (513.68 lb)
Dry weight (without fuel) (Caponord 1200 Travel Pack)	247 kg (544.54 lb)

Dry weight (without fuel) (Caponord 1200 Rally)	257 kg (566.59 lb)
--	--------------------

### **ENGINE**

Model	M558M
Type	90° longitudinal V-twin, 4-stroke, 4 valves per cylinder, 2 overhead camshafts.
No. of cylinders	2
Total engine capacity	1,197 cm <sup>3</sup> (73.05 cu in)
Bore / stroke	106 x 67.8 mm (4.17 x 2.67 in)
Compression ratio	12.0 +/- 0.5: 1
Electric	Electric starter
Engine idle speed	1450 ± 100 rpm
Clutch	Multiple-disk, oil-bathed clutch with control on the left side of the handlebar
Lubrication	Wet crankcase. Pressure system regulated by a trochoidal pump with oil radiator.

Air filter	Sponge.
Cooling	Fluid

### **GEARBOX**

Type	Mechanical, 6 speeds with foot lever on the left hand side of the engine
------	--

### **CAPACITY**

Fuel tank (reserve included)	24 l (5.28 UK gal; 6.34 US gal)
Fuel reserve	4 l (0.88 UK gal; 1.06 US gal)
Engine oil	3.1 l (without oil filter change) (0.68 UK gal; 0.82 US gal) 3.35 l (with oil filter change) (0.74 UK gal; 0.88 US gal)
Coolant	2.5 l (0.55 UK gal; 0.66 US gal)
Seats	2
Maximum weight limit (Caponord 1200/Caponord 1200 Travel Pack)	473 kg (1,042.78 lb)

Maximum weight limit (Caponord 1200 Rally)	497 kg (1095.70 lb)
--	---------------------

### **GEAR RATIOS**

Gear ratio	Gear primary drive 40/69
1st gear ratio	14/36 (secondary)
2nd gear ratio	17/32 (secondary)
3rd gear ratio	20/30 (secondary)
4th gear ratio	22/28 (secondary)
5th gear ratio	23/26 (secondary)
6th gear ratio	24/25 (secondary)
Final gear ratio	17/42

### **DRIVE CHAIN**

Type	Endless (without master link) and with sealed links. No. of links 112
Model	525 ZRPK

## **FUEL SYSTEM**

Type	Electronic injection (Multipoint)
Throttle valve diameter	Ø 52 mm (2.05 in)
Fuel	Premium unleaded petrol, minimum octane rating 95 (NORM) and 85 (NOMM)

## **CHASSIS**

Type	Component chassis (bolted). Die-cast aluminium plates and high-strength steel tubular chassis
Steering inclination angle	24°
Trail with suspension fully extended (without load) (Caponord 1200/Caponord 1200 Travel Pack)	128 mm (5.04 in)
Trail with suspension fully extended (without load) (Caponord 1200 Rally)	118 mm (5.04 in)



**SUSPENSION**

Front (Caponord 1200)	Telescopic "UPSIDE-DOWN" fork (upside-down stanchions) fork with full-adjustable stanchions with 43 mm (1.69 in) diameter (adjustment of hydraulic brake extended on left stanchion and compression on right stanchion and of spring preload on both)
Front (Caponord 1200 Travel Pack/Caponord 1200 Rally)	Telescopic "UPSIDE-DOWN" fork (upside-down stanchions) fork with stanchions with 43 mm (1.69 in) diameter, hydraulic braking dynamic adjustment during extension and compression (semi-active Aprilia Dynamic Damping technology) on left stanchion; and of spring preload on right stanchion, manually adjustable
Travel	173 mm (6.81 in)
Rear (Caponord 1200)	Oscillating swingarm connected with cantilever type link to a Sachs single shock absorber, with adjustment of hydraulic braking during extension and spring preload with knob.
Rear (Caponord 1200 Travel Pack/Caponord 1200 Rally)	Oscillating swingarm connected with cantilever type link to a Sachs single shock absorber, with adjustment of hydraulic braking during extension and compression (semi-active Aprilia Dynamic Damping technology) with "piggy-

	back" tank and automated management (or manually on instrument panel) of spring preload via electro-hydraulic system.
Travel	48 mm (1.89 in)
Rear wheel travel	148 mm (5.83 in)

### **BRAKES**

Front	Double floating disc, Ø 320 mm (12.60 in), radially-mounted calliper with four Ø 32 mm (1.26 in) pistons and two calliper pads.
Rear	240 mm (9.45 in) diam. disc brake with 35 mm (1.38 in) diam. single piston calliper.

### **WHEEL RIMS**

Type (Caponord 1200/Caponord 1200 Travel Pack)	Light alloy rims with extractable bolt
Type (Caponord 1200 Rally)	with spokes
Front (Caponord 1200/Caponord 1200 Travel Pack)	3.50 x 17"

Front (Caponord 1200 Rally)	3.00 x 19"
Rear (Caponord 1200/Caponord 1200 Travel Pack)	6.00 x 17"
Rear (Caponord 1200 Rally)	4.50 x 17"

### **TYRES**

Tyre type (standard)	DUNLOP QUALIFIER II (* Only for 78 kW - PIRELLI ANGEL GT versions)
Front tyre (Caponord 1200/ Caponord 1200 Travel Pack)	120/70 ZR17" (58W)
Front tyre (Caponord 1200 Rally)	120/70 R19" (60V)
Front tyre pressure	rider only: 2.4 bar (240 kPa) (34.81 PSI)  rider + passenger: 2.5 bar (250 kPa) (36.26 PSI)
Rear tyre (Caponord 1200/ Caponord 1200 Travel Pack)	180/55 ZR17" (73W) 190/55 ZR17" (75W) (*)
Rear tyre (Caponord 1200 Rally)	170/60 R17" (72V)
Rear tyre pressure	rider only: 2.6 bar (260 kPa) (37.71 PSI)

rider + passenger: 2.8 bar (280 kPa) (40.61 PSI)

### **SPARK PLUGS**

Standard spark plugs	NGK CR8EKB
Spark plug electrode gap	0.6 - 0.7 mm (0.024 - 0.028 in)
Resistance	5 kOhm

### **ELECTRICAL SYSTEM**

Battery	VTX14-BS 12 V - 12 Ampere/hour
Main fuses	30A
Secondary fuses	7.5 A; 10 A; 15 A
Alternator (permanent magnet type)	13 V - 690 W at 6,000 rpm

### **BULBS**

Low-/ high beam light	12V - 55W H11
Front daylight running lights	12V - 5W

Supplementary headlamps (Caponord 1200 Rally)	LED
Turn indicators	12V - 10W (White light)
Rear daylight running light / stop light	LED
License plate light	12V - 5W
Multifunction display lighting	LED

### **WARNING LIGHTS**

Turn indicators	LED
High beam light	LED
Fuel reserve	LED
Cruise control warning light	LED
Gear in neutral	LED
General warning	LED
ABS	LED
ATC (Option 01)	LED
MI (Option 02)	LED

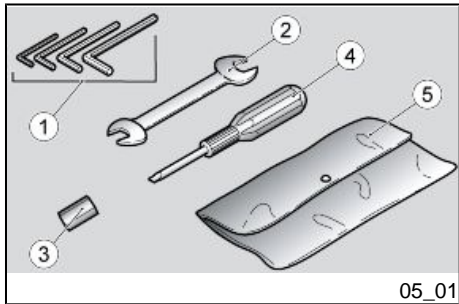

## Kit equipment (05\_01)

The tools supplied are:

- 3; 4; 5; 6 mm (0.12 0.16 0.20 0.24 in) L-shaped hex Allen keys (1);
- One 10 - 13 mm (0.39 - 0.51 in) double open ended spanner (2);
- Pliers to extract fuses (3);
- Double ended Phillips/hexagonal screwdriver (4);
- Toolkit pouch (5);

**Maximum weight allowed: 1.5 kg (3.3 lb)**

# CAPONORD 1200

**aprilia**



**Chap. 06  
Programmed  
maintenance**

## Scheduled maintenance table

Correct maintenance is fundamental for ensuring the longevity of your vehicle and maintaining optimum function and performance.

To this end, Aprilia offers a set of checks and maintenance services (at the owner's expense), that are summarised in the table shown on the following page. Any minor faults must be reported without delay to an **Authorised Aprilia Dealer or Sub-Dealer** without waiting until the next scheduled service to solve it.

All scheduled services must be carried out at the specified intervals and mileage, as soon as the predetermined mileage is reached. Carrying out scheduled services on time is essential for the validity of your warranty. For further information regarding Warranty procedures and "Scheduled Maintenance", please refer to the "Warranty Booklet".

### NOTE

**CARRY OUT MAINTENANCE OPERATIONS AT HALF THE INTERVALS SPECIFIED IF THE VEHICLE IS USED IN PARTICULAR RAINY OR DUSTY CONDITIONS, OFF ROAD OR FOR TRACK USE.**

I: INSPECT AND CLEAN, ADJUST, LUBRICATE OR REPLACE IF NECESSARY

C: CLEAN, R: REPLACE, A: ADJUST, L: LUBRICATE

- (1) Replace at whichever of the following occurs first: 40,000 km (24,854.85 mi) or 4 months
- (2) Replace every 2 years or 50,000 Km (31,068.56 mi)
- (3) Replace every 4 years
- (4) At each engine start
- (5) Check every month
- (6) Check each time the rear tyre is replaced



(7) Lubricate if you are riding in the rain, on wet roads or after the vehicle has been washed

**ROUTINE MAINTENANCE TABLE**

<b>km x 1000 (mi x 1000)</b>	<b>1 (0.6)</b>	<b>10 (6.2)</b>	<b>20 (12.4)</b>	<b>30 (18.6)</b>	<b>40 (28.4)</b>
Rear shock absorber			I		I
Spark plug			R		R
Drive chain (7)	I	I	I	I	I
Transmission cables and controls	I		I		I
Steering bearings and steering clearance	I		I		I
Wheel bearings			I		I
Diagnosis by tool	I	I	I	I	I
Brake discs	I		I		I
Air filter			R		R
Engine oil filter	R		R		R
Fork			I		I
General vehicle operation	I		I		I
Valve clearance			A		A
Cooling system			I		I
Braking systems	I		I		I
Light circuit	I		I		I
Safety switches			I		I
Clutch control fluid (2)	I		I		I

<b>km x 1000 (mi x 1000)</b>	<b>1 (0.6)</b>	<b>10 (6.2)</b>	<b>20 (12.4)</b>	<b>30 (18.6)</b>	<b>40 (28.4)</b>
Brake fluid (2)	I		I		I
Coolant (2)	I		I		I
Fork oil (1)					R
Engine oil	R		R		R
Light aiming			I		I
Fork oil seals		I	I	I	I
Flexible coupling (6)			I		I
Clutch lever pin (7)	L	L	L	L	L
Tyres - pressure/wear (5)	I	I	I	I	I
Wheels	I		I		I
Bolts and nuts tightening	I		I		I
Stand joint	L	L	L	L	L
Suspension and setting	I		I		I
Fault warning light on instrument panel (4)					
Spokes tension	I	I	I	I	I
Fuel lines (3)			I		I
Clutch wear			I		I
Break pad wear	I	I	I	I	I

**Table of recommended products (06\_01)**

**Piaggio & C. S.p.A.** prescribes **eni** products for the scheduled maintenance of its vehicles



06\_01

**RECOMMENDED PRODUCTS TABLE**

<b>Product</b>	<b>Description</b>	<b>Specifications</b>
ENI i-RIDE PG 15W-50	Engine oil	Use branded oils with performance equivalent to or exceeding API SJ, JASO MA - ACEA A3 - JASO MA2 specifications.
FUCHS TITAN SAF 1091	Fork oil (Caponord 1200)	-
OJ RACING FORK OIL TYPE 01	Fork oil (Caponord 1200 Travel Pack/ Caponord 1200 Rally)	-
FUCHS TITAN SAF 1091	Actuator oil of the active rear single shock absorber (Caponord 1200 Travel Pack/ Caponord 1200 Rally)	-
AGIP MP GREASE	Black smooth textured lithium-calcium soap based grease containing EP (extreme pressure) additives with optimal water-repellent properties	ISO L-X-BCHB 2 - DIN 51 825 KP2K-20
AGIP CHAIN LUBE SPRAY	Spray lubricating grease	-
AGIP BRAKE 4	Brake / Clutch fluid	SAE J 1703-FMVSS 116 - DOT 3/4 - ISO 4925 - CUNA NC 956 DOT 4 synthetic fluid

Product	Description	Specifications
AGIP PERMANENT SPECIAL	Ethylene glycol-based antifreeze fluid with organic inhibition additives. Red, ready to use.	ASTM D 3306 - ASTM D 4656 - ASTM D 4985 - CUNA NC 956-16

# TABLE OF CONTENTS

## A

ABS: 62  
Accessories: 75  
Air filter: 122

## B

Battery: 16, 127, 128  
Brake: 15, 125, 143

## C

Chain: 150–152  
Clutch: 15, 95, 126  
Clutch fluid: 15, 126  
Clutch lever: 95  
coolant: 14  
Coolant: 14

## D

Disc brake: 143  
Display: 33

## E

Engine oil: 15, 118–120  
Engine stop: 59

## F

Fork: 92  
Fuel: 12  
Fuses: 130

## G

Gearbox oil: 15

## H

Headlight: 137  
Horn: 54

## I

Identification: 74  
Immobilizer: 71

Instrument panel: 30

## L

Light switch: 57

## M

Maintenance: 117, 167, 168  
Maintenance Table: 168  
Mirrors: 141

## O

Oil filter: 120

## R

rear-view mirrors: 141  
Recommended products:  
171  
Ride by wire: 100

## S

Scheduled maintenance:  
168  
Shock absorbers: 88, 90  
Spark plug: 122  
Stand: 16, 108  
Start-up: 58  
Stop switch: 59

## T

Technical data: 155  
Transmission: 150  
Turn indicators: 140  
Tyres: 121

## W

Warning lights: 13



#### THE VALUE OF SERVICE

As a result of continuous updates and specific technical training programmes for Aprilia products, only **Aprilia** Official Network mechanics know this vehicle fully and have the specific tools necessary to carry out maintenance and repair operations correctly.

The reliability of the vehicle also depends on its mechanical conditions. Checking the vehicle before riding it, its regular maintenance and the use of **original Aprilia spare parts** only are essential factors!

For information on the nearest **Official Dealer and/or Service Centre** consult our website:

[www.aprilia.com](http://www.aprilia.com)

Only by requesting aprilia original spare parts can you be sure of purchasing products that were developed and tested during the actual vehicle design stage. All aprilia original spare parts undergo quality control procedures to guarantee reliability and durability.

The descriptions and images in this publication are given for illustrative purposes only and are not binding.

Piaggio & C. While the basic characteristics as described and illustrated in this booklet remain unchanged, Piaggio & C. S.p.A. reserves the right, at any time and without being required to update this publication beforehand, to make any changes to components, parts or accessories, which it considers necessary to improve the product or which are required for manufacturing or construction reasons.

Not all versions/models shown in this publication are available in all Countries. The availability of individual versions/models should be confirmed with the official Aprilia sales network.

The Aprilia trademark is the property of Piaggio & C. S.p.A.

© Copyright 2015 - Piaggio & C. S.p.A. All rights reserved. Reproduction of this publication in whole or in part is prohibited.

Piaggio & C. S.p.A. Viale Rinaldo Piaggio, 25 - 56025 PONTEDERA (PI), Italy

[www.piaggio.com](http://www.piaggio.com)