

## **APRILIA WOULD LIKE TO THANK YOU**

for choosing one of its products. We have compiled this booklet to provide a comprehensive overview of your vehicle's quality features. Please read it carefully before riding the vehicle for the first time. It contains information, tips and precautions for using your vehicle. It also describes features, details and devices to assure you that you have made the right choice. We believe that if you follow our suggestions, you will soon get to know your new vehicle well and that it will continue to give you satisfactory service for many years to come. This booklet is an integral part of the vehicle and must be handed over to the new owner in the event of sale.

# **SHIVER 750 - SHIVER 750 ABS**

The Aprilia logo consists of the word "aprilia" in a white, lowercase, sans-serif font, centered within a solid red rectangular background.

The instructions given in this manual are intended to provide a clear, simple guide to using your vehicle; it also describes routine maintenance procedures and regular checks that should be carried out on the vehicle at an **Aprilia Dealer or Authorised Workshop**. The booklet also contains instructions for simple repairs. Any operations not specifically described in this booklet require the use of special tools and/or particular technical knowledge: for these operations, please take your vehicle to an **Aprilia Dealer or Authorised Workshop**.



### **Personal safety**

Failure to completely observe these instructions will result in serious risk of personal injury.



### **Safeguarding the environment**

Sections marked with this symbol indicate the correct use of the vehicle to prevent damaging the environment.



### **Vehicle intactness**

The incomplete or non-observance of these regulations leads to the risk of serious damage to the vehicle and sometimes even the invalidity of the guarantee

*The symbols illustrated above are very important. They are used to highlight parts of the booklet that should be read with particular care. The different symbols are used to make each topic in the manual simple and quick to locate. Before starting the engine, read this booklet carefully, particularly the "SAFE RIDING" section. Your safety as well as other's does not only depend on the quickness of your reflexes and agility, but also on how well you know your vehicle, the state of maintenance of the vehicle itself and your knowledge of the rules for SAFE RIDING. For your safety, get to know your vehicle well so as to safely ride and master it given any riding condition. **IMPORTANT** This booklet is an integral part of the vehicle, and must be handed to the new owner in the event of sale.*



# INDEX

<b>GENERAL RULES</b> .....	7	Opening the saddle.....	51
Foreword.....	8	Glove/tool kit compartment.....	52
Motorcycle care.....	8	Identification.....	53
Carbon monoxide.....	11	<b>USE</b> .....	55
Fuel.....	12	Checks.....	56
Hot components.....	12	Refuelling.....	59
Warning lights.....	13	Rear shock absorbers adjustment.....	61
Coolant.....	13	Front fork adjustment.....	63
Used engine oil and gearbox oil.....	14	Justering af greb til forbremse.....	64
Brake and clutch fluid.....	15	Rear brake pedal adjustment.....	64
Battery hydrogen gas and electrolyte.....	15	Clutch lever adjustment.....	65
Stand.....	16	Running in.....	65
Reporting of defects that affect safety.....	16	Starting up the engine.....	66
<b>VEHICLE</b> .....	17	Ride by wire.....	69
Arrangement of the main components.....	19	Moving off / riding.....	70
Dashboard.....	24	Stopping the engine.....	74
Instrument panel.....	25	Parking.....	75
Light unit.....	26	Catalytic silencer.....	76
Digital lcd display.....	27	Stand.....	77
Alarms.....	30	Suggestion to prevent theft.....	77
Mapping selection.....	32	Basic safety rules.....	78
Control buttons.....	34	<b>MAINTENANCE</b> .....	85
Advanced functions.....	36	Engine oil level check.....	86
Ignition switch.....	43	Engine oil top-up.....	87
Locking the steering wheel.....	43	Engine oil change.....	88
Horn button.....	44	Engine oil filter replacement.....	89
Switch direction indicators.....	44	Tyres.....	90
Passing button.....	45	Spark plug dismantlement.....	92
Start-up button.....	45	Removing ducts.....	92
Engine stop switch.....	46	Removing the air filter.....	93
System ABS.....	46	Cooling fluid level.....	94
Immobilizer system operation.....	49	Checking the brake oil level.....	96
Fairings.....	50	Braking system fluid top up.....	97

Checking clutch fluid.....	97
Topping up clutch fluid.....	97
Use of a new battery.....	98
Checking the electrolyte level.....	99
Charging the battery.....	99
Long periods of inactivity.....	100
Fuses.....	101
Lamps.....	104
Headlight adjustment.....	106
Front direction indicators.....	108
Rear optical unit.....	108
Rear turn indicators.....	109
Number plate light.....	109
Rear-view mirrors.....	110
Front and rear disc brake.....	111
Periods of inactivity.....	112
Cleaning the vehicle.....	114
Transport.....	117
Chain backlash check.....	117
Chain backlash adjustment.....	118
Checking wear of chain, front and rear sprockets.....	118
Chain lubrication and cleaning.....	119
<b>TECHNICAL DATA.....</b>	<b>121</b>
Kit equipment.....	130
<b>PROGRAMMED MAINTENANCE.....</b>	<b>131</b>
Scheduled maintenance table.....	132
Table of recommended products.....	134

# SHIVER 750 - SHIVER 750 ABS

**aprilia**



**Chap. 01**  
**General rules**

## Foreword

### NOTE

**CARRY OUT MAINTENANCE OPERATIONS AT HALF THE INTERVALS SPECIFIED IF THE VEHICLE IS USED IN PARTICULAR RAINY OR DUSTY CONDITIONS, OFF ROAD OR FOR TRACK USE.**

## Motorcycle care

Aprilia recommends using quality products to clean the vehicle. The use of unsuitable products can damage vehicle components. For cleaning do not use solvents such as "nitro thinner", "cold cleaning agents", fuels or similar, or cleaning products that contain alcohol.

### WASHING THE MOTORCYCLE

Aprilia recommends softening with plenty of water and then carefully removing the insects and more stubborn stains before washing the vehicle.

To prevent stains, do not wash the motorcycle immediately after exposure to sunlight, and do not wash it in the sun.

If the vehicle is used during the winter months, be sure to frequently wash the motorcycle. To remove anti-icing salt sprayed on roads in the winter, wash the motorcycle with cold water immediately after use.

### CAUTION

**AFTER CLEANING YOUR MOTORCYCLE, THE EFFICIENCY OF THE BRAKING SYSTEM MAY BE TEMPORARILY AFFECTED DUE TO THE PRESENCE OF WATER ON THE FRICTION SURFACES. CONSIDER AN INCREASE IN BRAKING SPACE, OPERATE THE BRAKES REPEATEDLY TO RESTORE NORMAL CONDITIONS. CARRY OUT THE PRE-RIDE CHECKS BEFORE USE.**





**USE OF HOT WATER INTENSIFIES THE EFFECT OF THE SALT. USE ONLY PLENTY OF COLD WATER TO WASH AND REMOVE ANTI-ICING SALT**



**USE OF HIGH PRESSURE WASHING SYSTEMS (OR STEAM CLEANERS) CAN DAMAGE THE SEALS, OIL SEALS, BRAKING SYSTEM, ELECTRICAL SYSTEM AND THE SADDLE. DO NOT USE STEAM OR HIGH PRESSURE CLEANING SYSTEMS. DO NOT USE STEAM OR HIGH PRESSURE CLEANING SYSTEMS.**

## **CLEANING OF SENSITIVE PARTS**

### **BODYWORK**

To keep the motorcycle bright, wash it regularly, especially if used in areas with high levels of pollution or mud. Aggressive stains from tree resins, gasoline, oil, brake fluid or bird excrement in general

must be removed immediately, otherwise permanent stains on the paint can appear. After washing it is easy to identify marks and residual stains, remove them from the body using a soft cloth and brand-name, non-abrasive polish, and protect with a protective wax for cars. Periodic care, a thorough cleaning and regular protective wax for the bodywork preserves the aesthetic quality of the motorcycle over the long term.

### **PLASTIC COMPONENTS**



**IF THE PLASTIC COMPONENTS ARE CLEANED USING AGGRESSIVE AGENTS, THE SURFACE MAY BE DAMAGED. DO NOT USE CLEANING PRODUCTS CONTAINING ALCOHOL, SOLVENTS OR THAT ARE ABRASIVE FOR THE CLEANING**

**OF PLASTIC PARTS. ROTARY BRUSHES OR SPONGES WITH HARD SURFACES CAN MAKE SCRATCHES**

#### **CHROME PARTS AND POLISHED METAL**



**TREAT THE PARTS MADE OF CHROME, ALUMINIUM OR POLISHED STEEL IN A SPECIAL MANNER. WASH THEM WITH PLENTY OF WATER AND CAR SHAMPOO, POLISH AND REGULARLY BRIGHTEN THEM WITH POLISH PASTE, PROTECT THEM WITH WAXES OR SUITABLE ACID-FREE PRODUCTS (E.G. VASELINE)**

#### **RADIATOR**



**IF USING THE MOTORCYCLE IN THE WINTER ON ROADS WITH DE-ICING SALT, REGULARLY WASH THE RADIATOR TO PREVENT AESTHETIC DAMAGE AND THE ENGINE FROM OVERHEATING. WASH USING PLENTY OF WATER. FOR EXAMPLE USE GARDEN RUBBER WITH WATER AT LOW PRESSURE.**

#### **RUBBER PARTS**

Clean the rubber parts using water and mild shampoo (brand-name, suitable for car bodies)



**THE USE OF SILICONE SPRAY TO CLEAN THE RUBBER SEALS MAY CAUSE DAMAGE. DO NOT USE OTHER PRODUCTS CONTAINING SILICON FOR CLEANING THE MOTORCYCLE**

## **Carbon monoxide**

If you need to keep the engine running in order to perform a procedure, please ensure that you do so in an open or very well ventilated area. Never let the engine run in an enclosed area. If you do work in an enclosed area, make sure to use a smoke-extraction system.

### **CAUTION**



**EXHAUST EMISSIONS CONTAIN CARBON MONOXIDE, A POISONOUS GAS WHICH CAN CAUSE LOSS OF CONSCIOUSNESS AND EVEN DEATH.**

### **CAUTION**



**CARBON MONOXIDE IS ODOURLESS AND COLOURLESS, THEREFORE IT CANNOT BE DETECTED BY SMELL, SIGHT OR OTHER SENSES. DO NOT BREATHE IN EXHAUST FUMES UNDER ANY CIRCUMSTANCES.**

## Fuel

### CAUTION



**THE FUEL USED TO POWER INTERNAL COMBUSTION ENGINES IS HIGHLY FLAMMABLE AND MAY BE EXPLOSIVE UNDER CERTAIN CONDITIONS. IT IS THEREFORE RECOMMENDED TO CARRY OUT REFUELLING AND MAINTENANCE PROCEDURES IN A VENTILATED AREA WITH THE ENGINE SWITCHED OFF. DO NOT SMOKE DURING REFUELLING AND NEAR FUEL VAPOURS, AVOIDING ANY CONTACT WITH NAKED FLAMES, SPARKS OR OTHER SOURCES WHICH MAY CAUSE THEM TO IGNITE OR EXPLODE.**

**DO NOT DISPERSE FUEL IN THE ENVIRONMENT.**

**KEEP OUT OF THE REACH OF CHILDREN**



**IF THE VEHICLE FALLS OR IS ON A STEEP INCLINE FUEL CAN LEAK.**

## Hot components

The engine and the exhaust system components get very hot and remain in this condition for a certain time interval after the engine has been switched off. Before handling these components, make sure that you are wearing insulating gloves or wait until the engine and the exhaust system have cooled down.

## Warning lights



**IF IF THE ALARM WARNING LAMP LIGHTS AND THE MESSAGE "SERVICE" OR "URGENT SERVICE" IS DISPLAYED WHILE THE ENGINE IS RUNNING NORMALLY, THIS INDICATES THAT THE ELECTRONIC CONTROL UNIT HAS DETECTED A FAILURE.**

**IN MANY CASES THE ENGINE WILL CONTINUE TO OPERATE WITH LIMITED PERFORMANCE; IMMEDIATELY CONTACT AN Official Moto Guzzi Dealer.**



**IF ENGINE OIL PRESSURE WARNING LIGHT AND THE TEXT ON THE DISPLAY REMAIN ON, OR IF THEY TURN ON DURING THE NORMAL OPERATION OF THE ENGINE, IT MEANS THAT THE OIL PRESSURE IN THE CIRCUIT IS INSUFFICIENT. IN THIS CASE THE ENGINE MUST BE IMMEDIATELY SHUT OFF IN ORDER TO AVOID ANY POSSIBLE DAMAGE.**



**PERFORM THE MOTOR OIL LEVEL CHECK. IF THE INSUFFICIENT MOTOR OIL PRESSURE LIGHT REMAINS DESPITE THE ABOVE PROCEDURE BEING PERFORMED CORRECTLY, CONTACT AN AUTHORIZED Moto Guzzi Dealer TO HAVE THE SYSTEM CHECKED.**

## Coolant

The coolant contains ethylene glycol which, under certain conditions, can become flammable. When ethylene glycol burns, it produces an invisible flame which can nevertheless cause burns.

**CAUTION**

**TAKE CARE NOT TO POUR COOLANT ONTO HOT ENGINE OR EXHAUST SYSTEM COMPONENTS; THE FLUID MAY CATCH FIRE AND BURN WITH INVISIBLE FLAMES. WHEN CARRYING OUT MAINTENANCE OPERATIONS, IT IS ADVISABLE TO WEAR LATEX GLOVES. EVEN THOUGH IT IS TOXIC, COOLANT HAS A SWEET FLAVOUR WHICH MAKES IT VERY ATTRACTIVE TO ANIMALS. NEVER LEAVE THE COOLANT IN OPEN CONTAINERS IN AREAS ACCESSIBLE TO ANIMALS AS THEY MAY DRINK IT.**

**KEEP OUT OF THE REACH OF CHILDREN**

**DO NOT REMOVE THE RADIATOR CAP WHEN THE ENGINE IS STILL HOT. THE COOLANT IS UNDER PRESSURE AND MAY CAUSE BURNS.**

**Used engine oil and gearbox oil****CAUTION**

**IT IS ADVISABLE TO WEAR PROTECTIVE IMPERMEABLE GLOVES WHEN SERVICING THE VEHICLE.**

**THE ENGINE OR GEARBOX OIL MAY CAUSE SERIOUS INJURIES TO THE SKIN IF HANDLED FOR PROLONGED PERIODS OF TIME AND ON A REGULAR BASIS.**

**WASH YOUR HANDS CAREFULLY AFTER HANDLING OIL.**

**HAND THE OIL OVER TO OR HAVE IT COLLECTED BY THE NEAREST USED OIL RECYCLING COMPANY OR THE SUPPLIER.**

**DO NOT DISPOSE OF OIL IN THE ENVIRONMENT**

KEEP OUT OF THE REACH OF CHILDREN

## Brake and clutch fluid

Brake and clutch fluid



**BRAKE AND CLUTCH FLUIDS CAN DAMAGE THE PLASTIC OR RUBBER PAINTED SURFACES. WHEN SERVICING THE BRAKING SYSTEM OR THE CLUTCH SYSTEM, PROTECT THESE COMPONENTS WITH A CLEAN CLOTH. ALWAYS WEAR PROTECTIVE GOGGLES WHEN SERVICING THESE SYSTEMS. BRAKE AND CLUTCH FLUIDS ARE EXTREMELY HARMFUL FOR YOUR EYES. IN THE EVENT OF ACCIDENTAL CONTACT WITH THE EYES, RINSE THEM IMMEDIATELY WITH ABUNDANT COLD, CLEAN WATER AND SEEK MEDICAL ADVICE.**

KEEP OUT OF THE REACH OF CHILDREN

## Battery hydrogen gas and electrolyte

CAUTION



**THE BATTERY ELECTROLYTE IS TOXIC, CORROSIVE AND AS IT CONTAINS SULPHURIC ACID, IT CAN CAUSE BURNS WHEN IN CONTACT WITH THE SKIN. WHEN HANDLING BATTERY ELECTROLYTE, WEAR TIGHT-FITTING GLOVES AND PROTECTIVE APPAREL. IN THE EVENT OF SKIN CONTACT WITH THE ELECTROLYTIC FLUID, RINSE WELL WITH PLENTY OF CLEAN WATER. IT IS PARTICULARLY IMPORTANT TO PROTECT YOUR EYES BECAUSE EVEN TINY AMOUNTS OF BATTERY ACID MAY CAUSE BLINDNESS. IF THE FLUID GETS IN CONTACT WITH YOUR EYES, WASH WITH ABUNDANT WATER FOR FIFTEEN MINUTES AND CONSULT AN EYE SPECIALIST IMMEDIATELY. THE BAT-**

**TERY RELEASES EXPLOSIVE GASES; KEEP IT AWAY FROM FLAMES, SPARKS, CIGARETTES OR ANY OTHER HEAT SOURCES. ENSURE ADEQUATE VENTILATION WHEN SERVICING OR RECHARGING THE BATTERY.**

**KEEP OUT OF THE REACH OF CHILDREN**

**BATTERY LIQUID IS CORROSIVE. DO NOT POUR IT OR SPILL IT, PARTICULARLY ON PLASTIC COMPONENTS. ENSURE THAT THE ELECTROLYTIC ACID IS COMPATIBLE WITH THE BATTERY TO BE ACTIVATED.**

## **Stand**



**BEFORE SETTING OFF, MAKE SURE THE STAND HAS BEEN COMPLETELY RETRACTED TO ITS POSITION.**

**DO NOT REST THE RIDER OR PASSENGER WEIGHT ON THE SIDE STAND.**

## **Reporting of defects that affect safety**

Unless otherwise specified in this Use and Maintenance Booklet, do not remove any mechanical or electrical component.

### **CAUTION**

**SOME CONNECTORS IN THE VEHICLE MAY BE ACCIDENTALLY SWAPPED AND MAY COMPROMISE NORMAL VEHICLE OPERATION IF INCORRECTLY INSTALLED.**



# SHIVER 750 - SHIVER 750 ABS



**Chap. 02**  
**Vehicle**

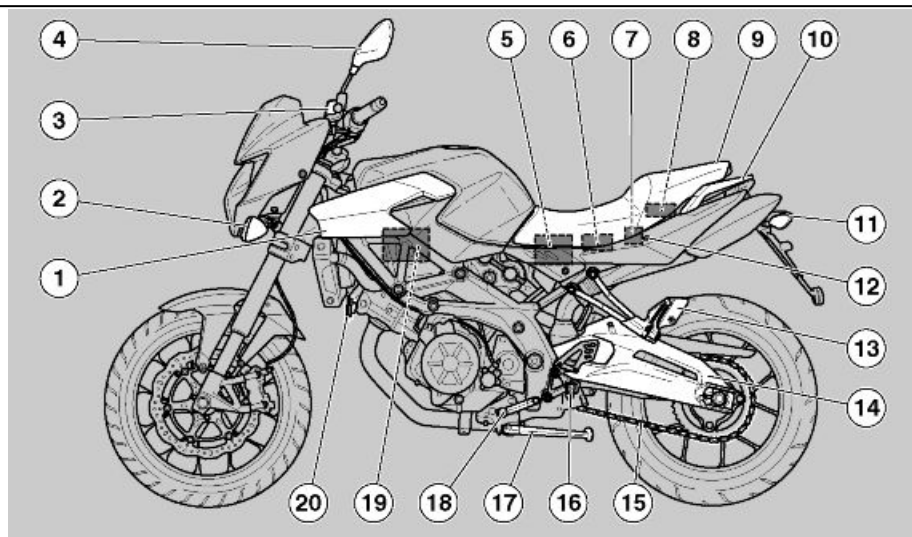

02\_01

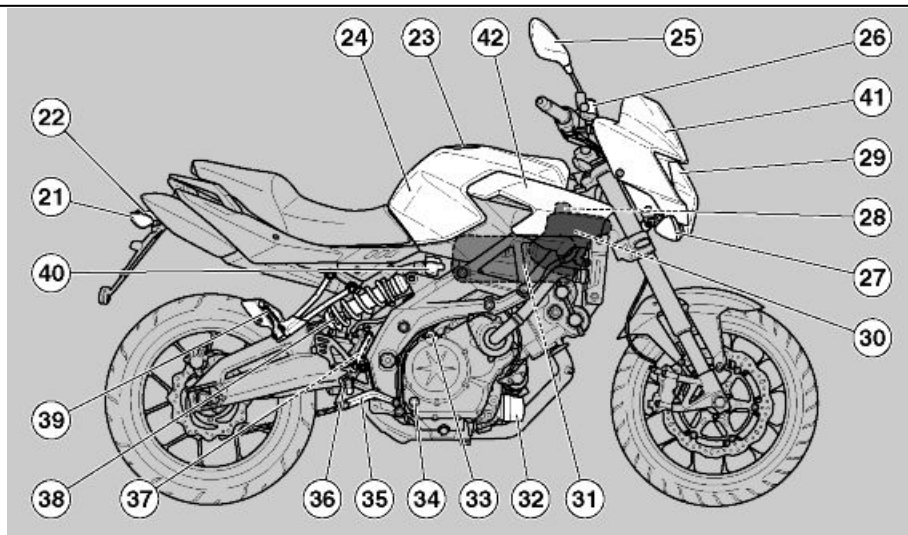

02\_02

## Arrangement of the main components (02\_02)

### Key - version without ABS:

1. Left duct
2. Front left turn indicator
3. Clutch fluid reservoir
4. Left rear-view mirror
5. Battery
6. Glove-box / toolkit
7. Main fuses
8. Auxiliary fuses
9. Saddle
10. Taillight
11. Rear left turn indicator

12. Glove-box / toolkit lock
13. Left passenger footrest (snap-on, closed / open)
14. Swingarm
15. Drive chain
16. Left rider footrest
17. Side stand
18. Gear shift lever
19. Control unit
20. Horn
21. Rear right turn indicator
22. License plate holder light
23. Fuel tank cap
24. Fuel tank
25. Left rear-view mirror
26. Front brake fluid reservoir
27. Front right turn indicator
28. Expansion tank cap
29. Headlamp
30. Expansion tank
31. Air filter
32. Engine oil filter
33. Engine oil plug
34. Engine oil level
35. Rear brake lever
36. Right rider footrest
37. Rear brake pump
38. Rear shock absorber
39. Right passenger footrest (snap-on, closed / open)
40. Rear brake fluid reservoir
41. Windshield
42. Right duct

**ABS**

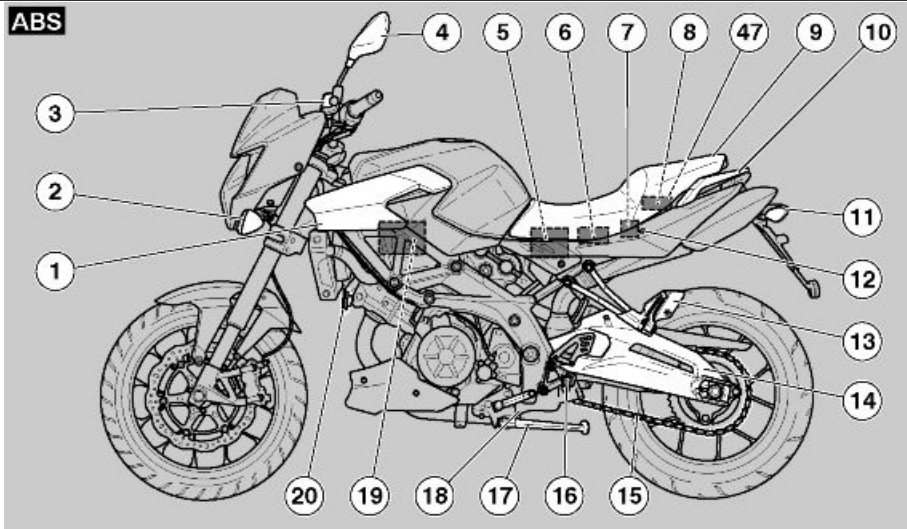

02\_03

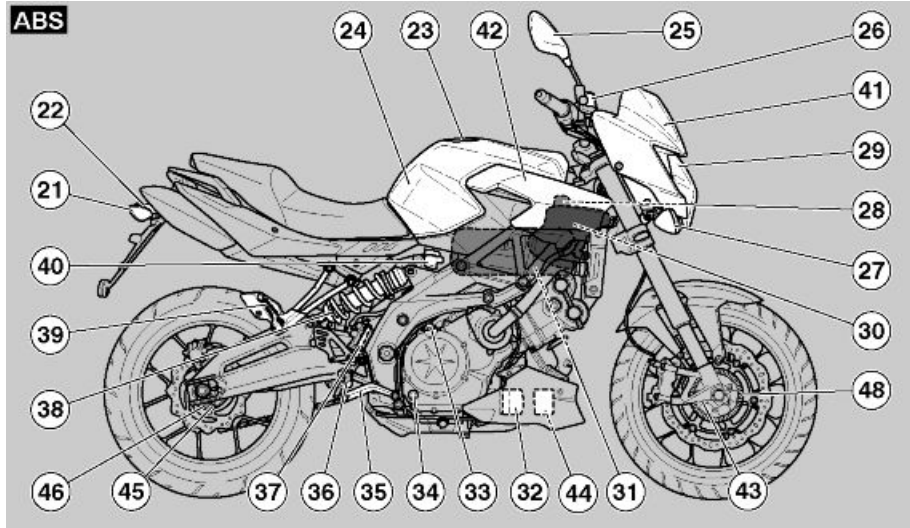

02\_04

**Key - version with ABS:**

1. Left duct
2. Front left turn indicator
3. Clutch fluid reservoir
4. Left rear-view mirror
5. Battery
6. Glove-box / toolkit
7. Main fuses
8. Auxiliary fuses
9. Saddle
10. Taillight
11. Rear left turn indicator
12. Glove-box / toolkit lock
13. Left passenger footrest (snap-on, closed / open)

14. Swingarm
15. Drive chain
16. Left rider footrest
17. Side stand
18. Gear shift lever
19. Control unit
20. Horn
21. Rear right turn indicator
22. License plate holder light
23. Fuel tank cap
24. Fuel tank
25. Left rear-view mirror
26. Front brake fluid reservoir
27. Front right turn indicator
28. Expansion tank cap
29. Headlamp
30. Expansion tank
31. Air filter
32. Engine oil filter
33. Engine oil plug
34. Engine oil level
35. Rear brake lever
36. Right rider footrest
37. Rear brake pump
38. Rear shock absorber
39. Right passenger footrest (snap-on, closed / open)
40. Rear brake fluid reservoir
41. Windshield
42. Right duct
43. Front ABS sensor
44. ABS control unit
45. Rear ABS sensor
46. Rear tone wheel
47. ABS fuses
48. Front tone wheel

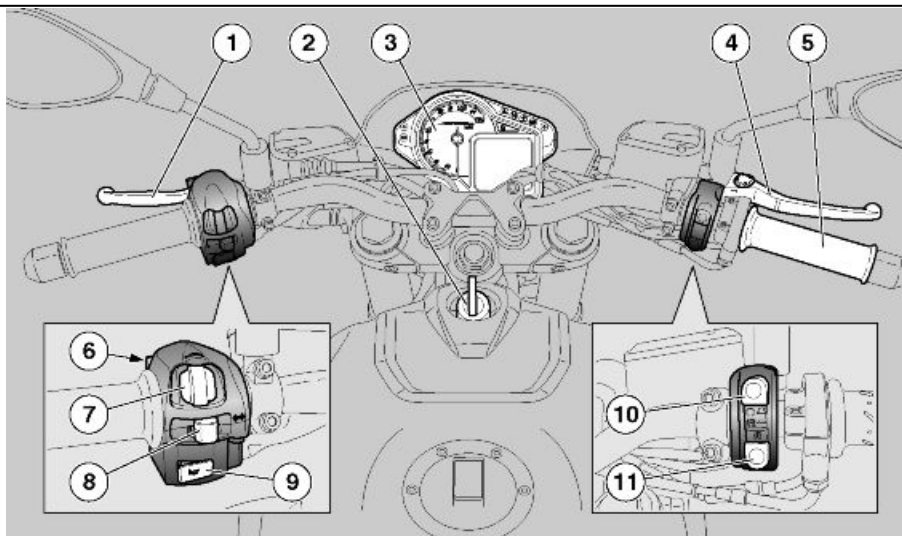

02\_05

## Dashboard (02\_05)

### Instrument panel / controls location key

1. Clutch control lever
2. Ignition switch /steering lock
3. Instrument panel
4. Front brake lever
5. Throttle grip
6. High beam flashing switch
7. MODE Control
8. Turn indicator control
9. Horn button
10. Engine stop button



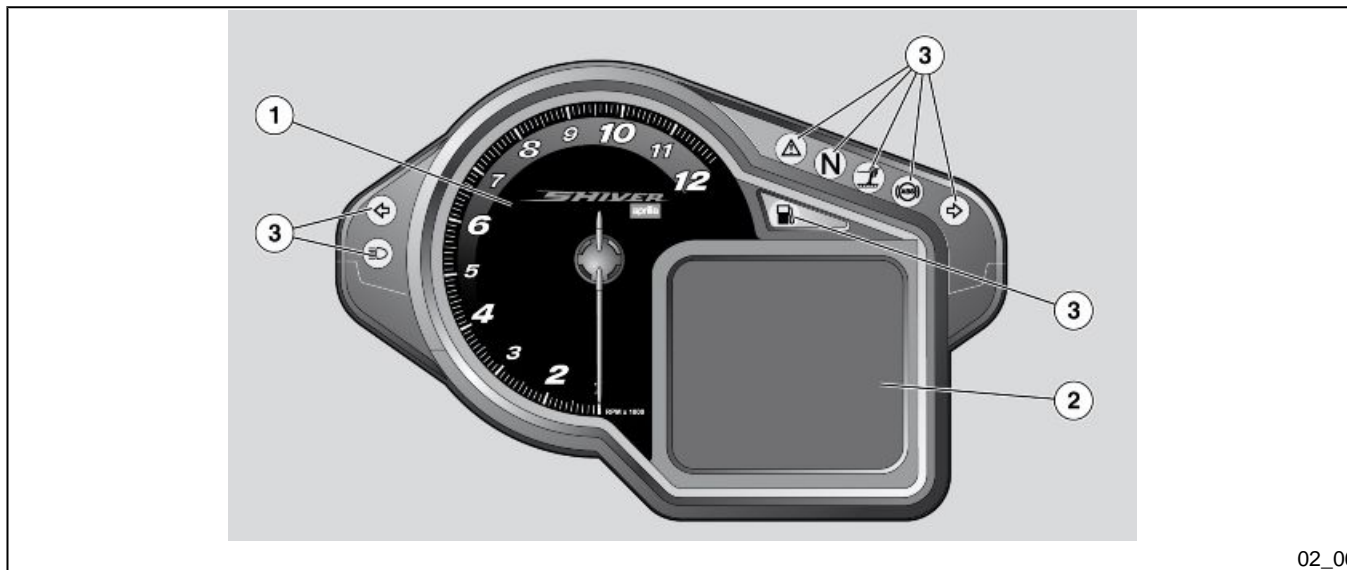

02\_06

### Instrument panel (02\_06)

**key:**

- 1. Rpm indicator
- 2. Multifunctional digital display
- 3. Warning lights

The instrument panel has an immobilizer system which prevents start-up in case the system does not identify a key which has been stored before.

The vehicle is supplied with two keys already programmed. The instrument panel accepts a maximum of four keys at the same time: contact an Official **Aprilia** Dealer to enable these keys or to disable a key that has been lost. When the vehicle is delivered and approximately ten seconds after the key is set to ON, the instrument panel requests a personal five-digit code to be entered. This request is no longer displayed once the personal code is entered. For code entering procedure, see the CODE MODIFICATION section

**It is important to remember the personal code because:**

- **the vehicle can be started if the immobilizer system is faulty**
- **the instrument panel need not be replaced should the ignition switch be changed**
- **new keys can be programmed**

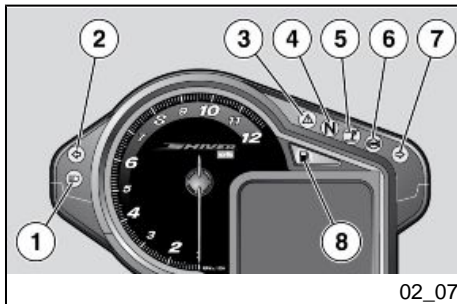

### Light unit (02\_07)

key:

1. Blue high beam warning light
2. Green left turn indicator warning light
3. General warning light, red
4. Gear in neutral warning light, green
5. Side stand lowered warning light, amber yellow
6. ABS warning light, red
7. Right turn indicator warning light, green
8. Low fuel warning light, amber yellow

## Digital lcd display (02\_08, 02\_09, 02\_10, 02\_11, 02\_12, 02\_13, 02\_14, 02\_15)

- By turning the ignition key to 'KEY ON', the following indicators on the instrument panel are lit for two seconds:
  - The 'SHIVER' logo
  - All warning lights
  - The rpm indicator pointer moves and then goes back to its original position.

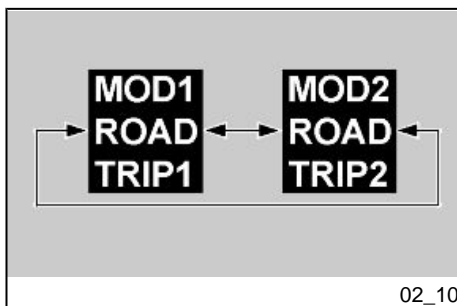
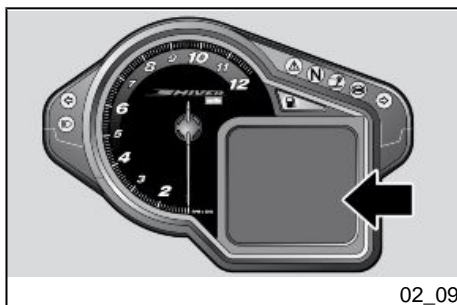

### NOTE

EVERY TIME THE SELECTOR IS HELD DOWN TO THE RIGHT OR LEFT, YOU CAN GO FROM ONE CONFIGURATION TO ANOTHER.

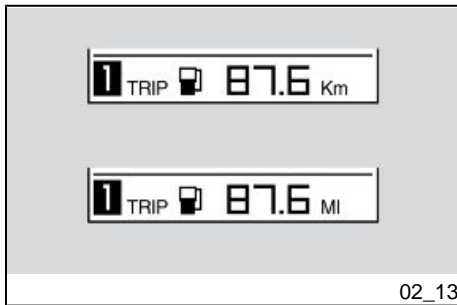

## ROAD MODE TRIP 1 / TRIP 2

- **The following functions are displayed at the top of the instrument panel:**

- Gear engaged (this is a calculated value so is displayed with a slight delay only when the vehicle is moving and with the clutch pulled) or rev number.
- Clock (displayable in the 24H mode and in the 12H mode without giving AM / PM indication) or chronometer (selectable from the menu).
- ambient temperature (displayed in °C or °F)

- **The following functions are displayed in the middle of the instrument panel:**

- map selected (top left);
- speed (speedometer);
- Engine temperature bar;

- **The following functions are displayed at the bottom of the instrument panel:**

- Total trip counter
- Trip computer diary;
- Active alarms.

2 km (1.24 mi) after the low fuel warning light turns on, the kilometres travelled with low fuel are shown on the digital display.

When active, it disappears after pressing one of the joystick controls to reappear after 60 seconds.

If the vehicle is using the fuel reserve, the warning light turns on 60 seconds after "KEY ON".

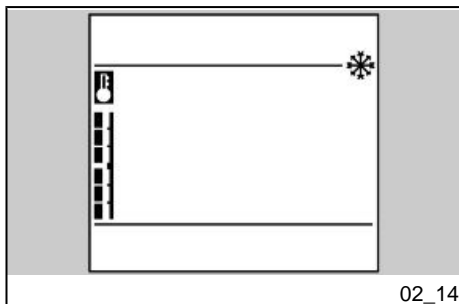

When the external temperature is below or equal to 3°C (37°F), the display shows the ice alarm icon.

When the threshold of the maintenance intervals is exceeded, an icon with a spanner is shown. This indicator may be reset once the scheduled service has been completed by an **authorised Aprilia Dealer or service centre**.

The "spanner" icon flashes for five seconds when the key is set to "KEY ON" and less than 300 km before the scheduled maintenance deadline.

With the key set to "KEY OFF" the general alarm warning light flashes to indicate activation of the locking system. To minimise battery consumption the light stops flashing after 48 hours.

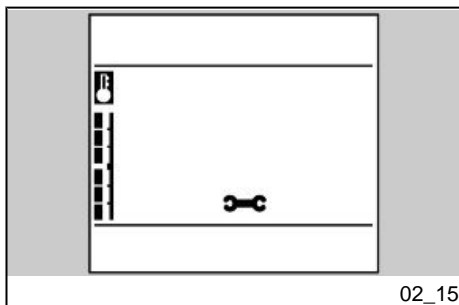

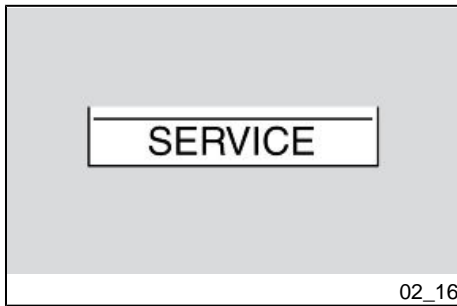

## Alarms (02\_16, 02\_17, 02\_18, 02\_19, 02\_20, 02\_21)

In case of failure, a different icon is displayed according to the cause at the bottom of the display.

Take your vehicle as soon as possible to an Official **Aprilia** Dealer.

### SERVICE ALARM

In case of failure found in the instrument panel or in the electronic control unit, the instrument panel signals the failure by displaying the SERVICE icon and the red general warning light comes on.

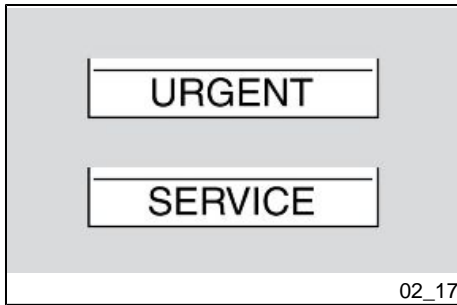

If there is an immobilizer failure at ignition, the instrument panel requests you to enter a user code. If the code is entered correctly, the instrument panel signals the failure by displaying the SERVICE icon and the red general warning light comes on.

### URGENT SERVICE ALARM

A serious failure is signalled by a fast flashing (two flashes per second) of the general warning light and by the URGENT and SERVICE words alternately being shown on the digital display. Take your vehicle as soon as possible to an Official **Aprilia** Dealer. In these cases, the control unit activates a safety procedure that limits the vehicle performance so that the rider is able to reach an Official **Aprilia** Dealer at low speed. According to the type of failure, performance can be limited in two ways: a) by reducing the maximum torque produced; b) by keeping the engine at idle speed but slightly accelerated (during this operation, the throttle control is disabled).

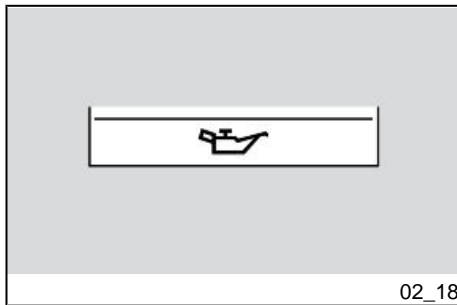

### Air temperature sensor failure

In case of air temperature sensor failure, this alarm is signalled on the instrument panel by displaying the fixed "--" symbol where the temperature indicator generally is. In this case the red general warning light does not turn on.

### Oil failure

In case of failing oil pressure or oil pressure sensor failure, the bulb and the red general warning light turn on the instrument panel.

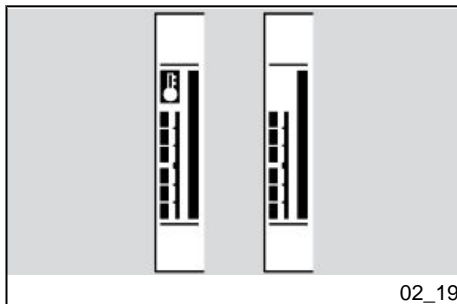

### Engine overheating alarm

The engine overheating alarm is activated when the temperature is higher than or equal to 110 °C (230 °F). The red general warning light turns on and the thermometer icon flashes on the display to signal this condition.

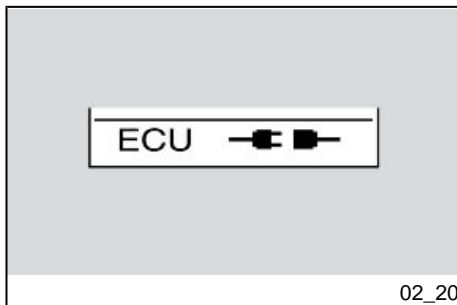

### Electronic control unit disconnected alarm

In case no connection is detected, the disconnection icon is displayed on the instrument panel and the red general warning light turns on to signal this condition.

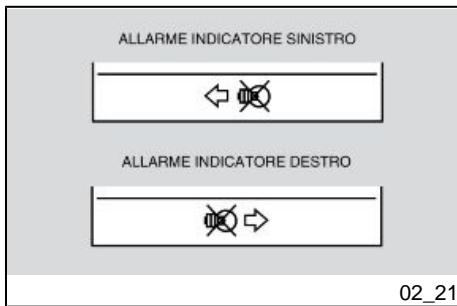

### Turn indicator malfunction

When the instrument panel detects a failing turn indicator, the turn indicator warning light flashes twice as fast and the problem is signalled on the digital display.



### Mapping selection (02\_22, 02\_23, 02\_24)

The engine control unit foresees 3 different "mapping" variants to manage the electronic throttle grip, which are displayed as seen in the upper left section of the instrument panel digital display:

- **T** is the **TOURING** mapping
- **S** is the **SPORT** mapping
- **R** is the **RAIN** mapping

The **TOURING** mode has been thought for smooth tourist riding.

In the **SPORT** mode you get more acceleration; this variant has been thought for a sporting use of the vehicle.



### CAUTION

**ONLY EXPERT RIDERS, RIDING ON ROADS WITH GOOD GRIP ARE ADVISED TO USE THIS MODE. IT IS NOT RECOMMENDED FOR WET SURFACES AND/OR ROADS WITH LOW GRIP.**





The **RAIN** mode has been thought for riding on wet surfaces or roads with low grip. The system reduces the maximum torque supplied by the engine and smoothly delivers it so as to prevent loss of grip. In this mode, the vehicle performance is limited, and therefore, the maximum speed cannot be reached.

**EVEN IN THIS MODE, ALWAYS USE PARTICULAR CAUTION WHEN RIDING IN POOR GRIP CONDITIONS.**

Push the starter button to go through the different mappings. Five seconds after the engine is started, this button can be used as a mapping selection button.

#### CAUTION

**MAP SELECTION IS ONLY PERMITTED WITH THE ENGINE RUNNING AND THE THROTTLE RELEASED. MAP SELECTION IS ALSO POSSIBLE WITH THE MOTORCYCLE IN MOTION, PROVIDED THAT THE THROTTLE GRIP IS RELEASED.**

To change mappings, proceed as follows:

- press the button once and the symbol for the mapping currently being used is shown "in negative" on the display
- press the button a second time, and within 1.5 seconds from the first pressing, the next mapping is selected and highlighted "in negative" on the display. If more than 1.5 seconds elapse and the button is not pressed again (the next mapping is otherwise selected) and without twisting the throttle control, the

new mapping is highlighted "in positive" on the display. This means that the new mapping is applied for all practical purposes.

#### CAUTION

**IN CASE THE THROTTLE GRIP IS TWISTED WHEN THE NEW MAPPING CHOSEN IS HIGHLIGHTED "IN NEGATIVE" ON THE DISPLAY, HENCE STILL BEING ACCEPTED BY THE ECU, THE NEW MAPPING SELECTED STARTS FLASHING "IN POSITIVE" ON THE DISPLAY, BUT WILL NOT BE ACTUALLY APPLIED UNLESS THE THROTTLE CONTROL IS RELEASED.**

### Control buttons (02\_25, 02\_26, 02\_27, 02\_28)

#### Trip journal 1 and 2

There are two trip journals available.

Press and hold down the MODE control to the left to select the TRIP JOURNAL 1; icon "1" on the DIGITAL DISPLAY turns on.

Press and hold down the MODE control to the right to select the TRIP JOURNAL 2; icon "2" on the DIGITAL DISPLAY turns on.

In each journal, each time the MODE control is briefly pressed to the right or left, the following information is displayed in sequence:

ODOMETER

TRIP ODOMETER

TRAVELLING TIME

MAXIMUM SPEED

MEAN SPEED

AVERAGE FUEL CONSUMPTION

CURRENT FUEL CONSUMPTION

MENU (only with the vehicle at a standstill)

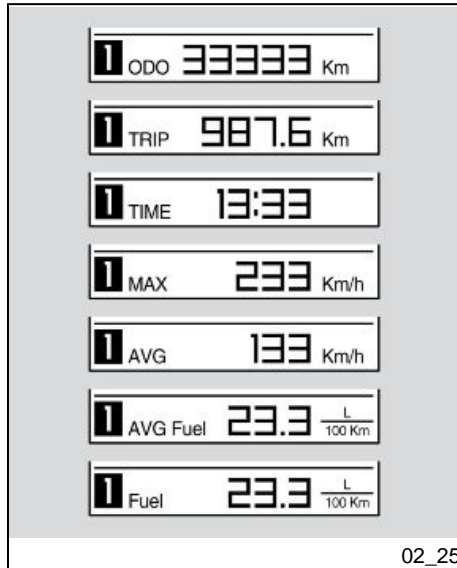

With the following options: TRIP ODOMETER, TRAVELLING TIME, MAXIMUM SPEED, MEAN SPEED, AVERAGE FUEL CONSUMPTION, press and hold down the central key to reset all the indications stored in the active TRIP JOURNAL.

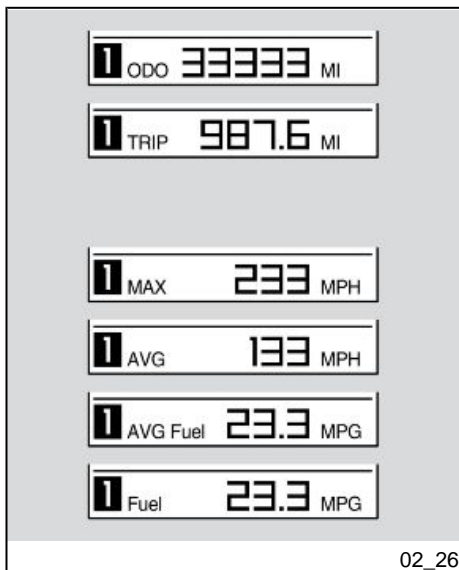

At zero speed, when the display shows the MENU, press and hold down the central button to access the instrument panel advanced functions.

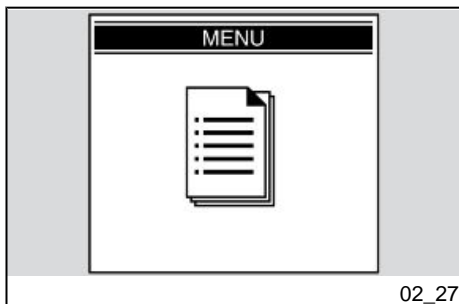

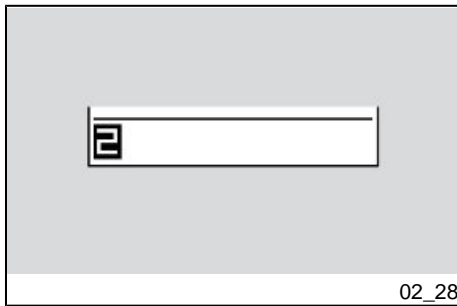

## CHRONOMETER

To use the chronometer, select the CHRONOMETER function from the MENU of the instrument panel advanced functions.

The chronometer is shown at the top of the digital display instead of the gear, clock and ambient temperature indicators.

With the vehicle in motion the chronometer functioning is controlled by means of the MODE control central button.

Press the central button briefly to start the chronometer. Timekeeping starts when the button is pressed. If the button is pressed again within 10 seconds after starting timekeeping, the chronometer is reset. After that time, and if the button is pressed again, the data is stored and the next timekeeping begins.

Timekeeping is cancelled by pressing and holding down the central button, or when speed goes back to zero; the display shows the last timekeeping. Timekeeping starts again following the steps described above.

After storing 40 times, this function is over. A new series of timekeeping can be started again only after deleting previous times stored by means of the MENU of the instrument panel advanced functions.



## Advanced functions (02\_29, 02\_30, 02\_31, 02\_32, 02\_33, 02\_34)

### MENU

The configuration menu can be opened from the menu screen page and consists of the following options:

- EXIT
- SETTINGS
- CHRONOMETER
- DIAGNOSIS
- LANGUAGES.

## SETTINGS

The SETTINGS menu consists of the following options:

- EXIT
- TIME ADJUSTMENT
- GEAR SHIFT
- BACKLIGHTING
- CHANGE THE CODE
- CODE RESET
- °C / °F
- 12/24 h

The functions of the settings menu are indicated in the following sections.

Once the operation is finished, the instrument panel goes back to the main menu.

### TIME ADJUSTMENT

The clock can be programmed with this option. The message "CLOCK ADJUSTMENT" is shown on the main display.

The minutes indicator is no longer displayed when this function is activated; only the hours indicator is shown. Each time the MODE selector is pressed to the right, the hour value increases; likewise, each time the MODE selector is pressed to the left, the hour value decreases. Press the MODE selector central part to store the set value and to shift to minute adjustment.

The minute indicator is no longer displayed when this function is activated; only the hour indicator is shown. Each time the MODE selector is pressed to the right, the minute value increases; likewise, each time the MODE selector is pressed to the left the minute value decreases.

Press the MODE selector central part to store the set value and to exit the clock adjustment function.



### GEAR SHIFT THRESHOLD

The gear shift threshold can be set in this mode. The main screen shows the message "GEAR SHIFT THRESHOLD".

Each time the MODE selector is pressed to the right, the threshold value increases by 100 RPM; contrariwise, each time the MODE selector is pressed to the left, the threshold value decreases by 100 RPM.

After reaching either the highest or lowest limit, the next time the selector is pressed will produce no effect.

The procedure ends when the MODE selector is pressed at the central position, which stores the set value, the pointer goes back to zero and the instrument panel goes back to the configuration menu.

When the battery is first activated, the instrument panel is set to the run-in rev value. Afterwards, the last set value is displayed:

- RUN-IN REVOLUTIONS: 6000 rpm
- MINIMUM REVOLUTIONS: 5000 rpm
- MAXIMUM REVOLUTIONS: 12000 rpm

If the set threshold value is exceeded, the warning light on the instrument panel starts to flash. It turns off when the value goes back below the threshold limit.

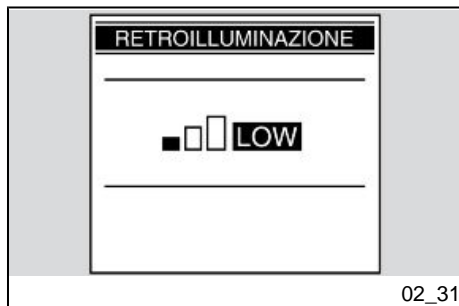

### BACKLIGHTING BRIGHTNESS

This function adjusts the backlighting brightness to three levels. Each time the MODE selector is pressed to the right or left, the following icons are shown:

- LOW
- MEAN
- HIGH

Once the operation is finished, when the MODE selector is pressed at central position, the instrument panel shows the SETTINGS menu.

When the battery is detached, the display is configured with the maximum level of brightness.

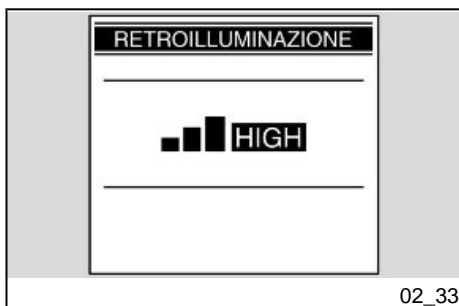
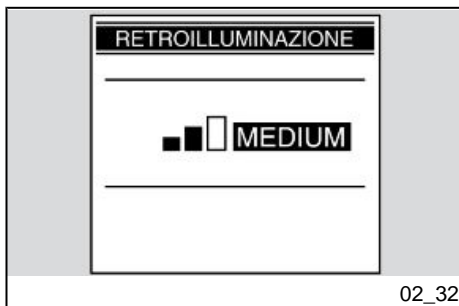

### CODE CHANGE

This function is used to modify an old code. Once you have entered this function, the following message is displayed:

"ENTER OLD CODE"

After recognising the old code, the new code is requested and the display shows the following message:

"ENTER NEW CODE"

Once the operation is finished, the display shows the DIAGNOSIS menu. If the code has been used, this operation is not allowed.

Once the operation is finished, the instrument panel shows the SETTINGS menu.

If it is the first time a code is stored, only the new code is requested.

### **CODE RESET**

This function is used to set a new code when the old one is not available; in this case, at least two keys will have to be inserted in the ignition lock. After the first key has been inserted, the second one is requested with the following message:

"INSERT KEY II"

In between keys, the instrument panel remains lit; if the key is not inserted within 20 seconds, the operation finishes. After recognising the second key, the insertion of the new code is required with the message:

"ENTER NEW CODE"

Once the operation is finished, the display shows the DIAGNOSIS menu. If the code has been used, this operation is not allowed.

Once the operation is finished, the instrument panel shows the SETTINGS menu.

### **°C/°F**

Select the °C / °F option from the SETTINGS menu for this function.

This function selects the unit of measurement for the ambient temperature: °C or °F.

### **12H / 24H**

Select the 12H / 24H option from the SETTINGS menu for this function.

This menu selects the clock display mode as 12h or 24h.

### **CHRONOMETER**



Select the CHRONOMETER option from the configuration menu to access the chronometer function. When the CHRONOMETER function is selected the screen page shows the following options:

- EXIT
- START CHRONOMETER
- VIEW TIMES
- DELETE TIMES

### Start chronometer

Select this option to display the screen that allows to select which function should be shown at the top of the display- clock or chronometer.

The instrument panel keeps the chosen configuration even after the key is extracted / inserted.

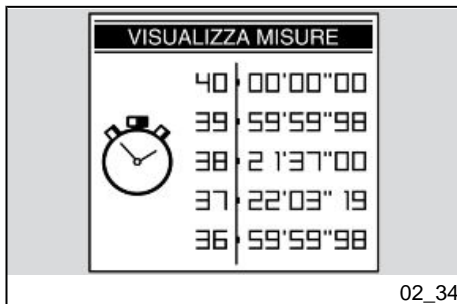

### View times

This option shows the stored chronometer times. Press the MODE selector for a couple of seconds to the right or left to scroll the time screens; hold it down to display the CHRONOMETER menu. If the battery is removed, the stored times are lost.

### Delete times

This option deletes the stored chronometer times. A deletion confirmation is requested. Once the operation is finished, the display goes back to the chronometer menu.

## **DIAGNOSIS**

Open the configuration menu to display the DIAGNOSIS option.

This menu interfaces with the systems present on the vehicle and diagnoses them. To enable this menu, enter an access code available only from official Aprilia dealers.

## **LANGUAGES**

Open the configuration menu to access the LANGUAGES function. Select the LANGUAGES option to choose the interface language.

The options are:

- ITALIANO
- ENGLISH
- FRANÇAIS
- DEUTSCH
- ESPAÑOL

Once the operation is finished, the display goes back to the LANGUAGES menu.

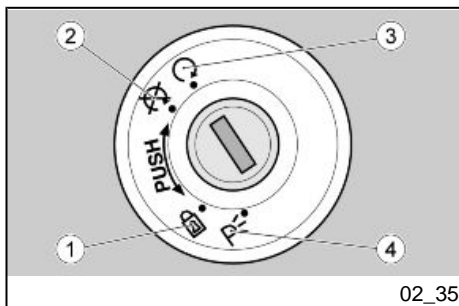

## Ignition switch (02\_35)

The ignition switch (1) is located at the front of the fuel reservoir.

The vehicle is supplied with two keys (one is the spare key).

The lights go off when the ignition switch is set to «OFF».

### NOTE

**THE KEY ACTIVATES THE IGNITION SWITCH AND OPERATES THE STEERING LOCK.**

### NOTE

**THE LIGHTS COME ON AUTOMATICALLY AFTER THE ENGINE STARTS.**

**LOCK (1):** The steering is locked. It is not possible to start the engine or switch on the lights. It is possible to remove the key

**OFF (2):** The engine and lights cannot be set to work. The key may be removed.

**ON (3):** the engine may be started. The key cannot be removed

**PARKING (4):** The steering is locked. The engine cannot be started. The lights of the front and rear headlamps are activated. The ignition key can be extracted. Once the key has been extracted, the immobilizer system is active (if present).

## Locking the steering wheel

### To lock the steering:

- Turn the handlebar completely to the left.
- Turn the key to «OFF».
- Push in the key and turn it anticlockwise (to the left), steer the handlebar slowly until the key is set to «LOCK».

- Remove the key.

**CAUTION**

**TO AVOID LOSING CONTROL OF THE VEHICLE, NEVER TURN THE KEY TO "LOCK" WHILE RIDING.**

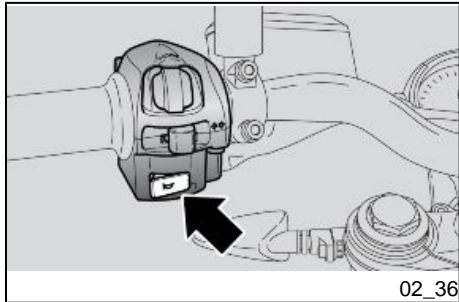
**Horn button (02\_36)**

Press it to activate the horn.

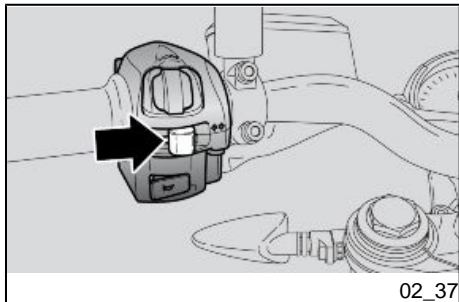
**Switch direction indicators (02\_37)**

Move the switch to the left, to indicate a left turn; move the switch to the right to indicate a right turn. Pressing the switch deactivates the turn indicator.

**CAUTION**

**IF THE WARNING LIGHT WITH ARROWS FLASHES QUICKLY, IT MEANS THAT ONE OR BOTH TURN SIGNALS LIGHT BULBS ARE BURNT OUT.**

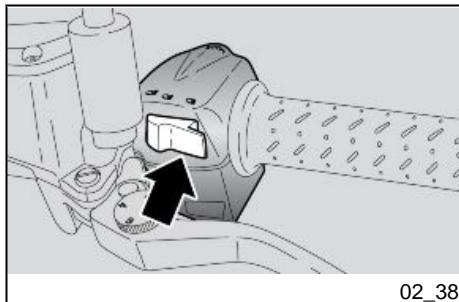

### Passing button (02\_38)

Uses the high beam flash in case of danger or emergency.

Releasing the switch deactivates the high beam flash.

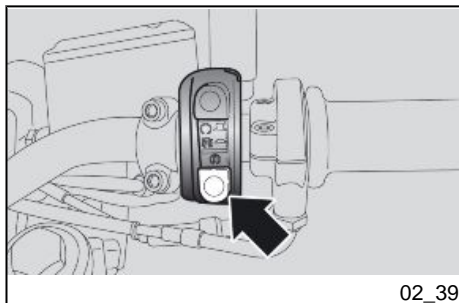

### Start-up button (02\_39)

Press the button and the starter motor spins the engine.

#### CAUTION

**FIVE SECONDS AFTER THE ENGINE IS STARTED, THIS BUTTON CAN BE USED AS "MAPPING SELECTION" BUTTON.**

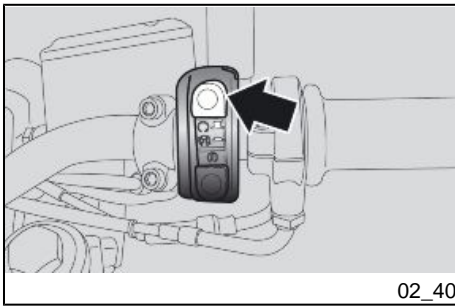

## Engine stop switch (02\_40)

It acts as an engine cut-off or emergency stop switch.

Press this switch to stop the engine.

## System ABS

### WHERE CONTEMPLATED

The ABS system is a device that prevents wheel locking in case of an emergency braking, thus increasing vehicle stability when braking, compared with a conventional braking system.

The ABS system enhances control over the vehicle, taking into consideration never to exceed the physical limits of vehicle grip on the road. The rider is fully responsible for riding at a suitable speed based on weather and road conditions, always leaving an appropriate safety margin.

Under no circumstances can the ABS system compensate for the rider's misjudgement or improper use of brakes.

### NOTE

**WHEN THE ABS SYSTEM STARTS WORKING, A VIBRATION IS FELT ON THE BRAKE LEVER.**



**THE ANTILOCK BRAKING SYSTEM OF THE WHEEL DOES NOT PREVENT FALLS WHILE CORNERING.**

**AN EMERGENCY BRAKING WITH THE VEHICLE INCLINED, HANDLEBAR TURNED, ON UNEVEN OR SLIPPERY ROADS, OR WITH POOR GRIP, CREATES A LACK OF STABILITY DIFFICULT TO HANDLE. RIDE CAREFULLY AND SENSIBLY AND ALWAYS BRAKE GRADUALLY.**

**DO NOT SPEED RECKLESSLY. THE VEHICLE GRIP ON THE ROAD IS SUBJECT TO LAWS OF PHYSICS WHICH NOT EVEN THE ABS SYSTEM CAN ELIMINATE.**

Upon starting the vehicle, after the initial instrument panel check, the ABS warning light flashes until a speed of 5 kph (3.1 mph) is exceeded and then it switches off or continues to flash even after exceeding the speed of 5 kph (3.1 mph).

If the ABS warning light continues flashing or is permanently on, a failure has been detected and the ABS has been automatically deactivated.

In this case carry out the following operations:

- stop the vehicle;
- key OFF-ON;
- ride over 5 km/h (3.1 mph): the ABS warning light must be turned off;
- the ABS system is working.

If the ABS disabled indication remains:

#### **NOTE**

**SHOULD THIS OCCUR, CONTACT AN aprilia Official Dealer.**

**NOTE**

**THE ABS SYSTEM HAS BEEN DESIGNED AND DEVELOPED, CONSISTENTLY WITH THE REST OF THE VEHICLE, TO BE USED ON TARMAc ROADS AND IT IS NOT SUITABLE FOR OFF-ROAD USE.**

**IF THE VEHICLE IS USED ON UNSURFACED AND/OR SPECIFICALLY ROUGH ROADS, THE ABS SYSTEM MAY GET DISABLED AUTOMATICALLY; IN ANY CASE, THE BRAKING SYSTEM WORKS PERFECTLY WELL AS A TRADITIONAL NON-ABS BRAKING SYSTEM AND PROVIDES A STANDARD STOP CAPACITY.**

**IN ORDER TO REACTIVATE THE SYSTEM JUST SHUT OFF AND START THE VEHICLE UP AGAIN AND RIDE OVER 5 km/h (3.1 mph).**



**THE ABS SYSTEM ACTS ON BOTH THE FRONT AND REAR WHEELS BY OBTAINING INFORMATION FROM THE ROTATION/ LOCKING TONE WHEELS. ALWAYS CHECK THAT THE TONE WHEEL IS CLEAN, AND REGULARLY CHECK THAT THE DISTANCE FROM THE SENSOR IS CONSTANT ON ALL 360 GRADES. SHOULD THE WHEELS BE REMOVED AND REFITTED, IT IS VERY IMPORTANT TO CHECK THAT THE DISTANCE BETWEEN TONE WHEEL AND SENSOR IS THE ONE SPECIFIED. FOR CHECKING AND ADJUSTMENT, CONTACT AN Authorised APRILIA Workshop.**



**IN THE CASE OF A MOTORCYCLE WITH THE ABS SYSTEM, BRAKE PADS WITH FRICTION MATERIALS THAT ARE NOT TYPE APPROVED WILL JEOPARDISE BRAKING, DRASTICALLY REDUCING RIDING SAFETY.**





**IF THE GAP FOR ONE OR BOTH SENSORS IS NOT WITHIN THE TOLERANCE INDICATED BELOW, TAKE THE MOTORCYCLE TO AN official Aprilia DEALER-SHIP**

### **Characteristic**

#### **Distance between tone wheel and rear sensor**

0.1 - 2.00 mm (0.004 - 0.079 in)

#### **Distance between tone wheel and front sensor**

0.1 - 3.17 mm (0.004 - 0.125 in)

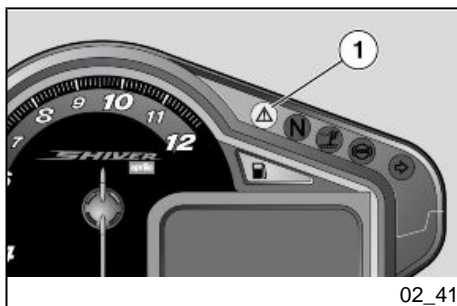

02\_41

### **Immobilizer system operation (02\_41)**

For enhanced theft protection, the vehicle is equipped with an electronic immobilizer system that is activated automatically when the ignition key is removed.

Keep the second key in a safe place since it is not possible to make a copy if it gets lost. This would imply replacing numerous parts of the vehicle (besides the locks).

Each key in the grip has an electronic device - transponder - which modulates the radio frequency signal emitted by a special built-in aerial in the switch when the vehicle is started.

The modulated signal is the "password" by which the appropriate central unit recognises the key and only after this occurs, it allows the engine start-up.

### **CAUTION**

**THE IMMOBILIZER SYSTEM CAN MEMORISE UP TO FOUR KEYS.**

**DATA STORAGE OPERATION CAN ONLY BE PERFORMED AT THE DEALER'S.**

**DATA STORAGE PROCEDURE CANCELS THE EXISTING CODES. THEREFORE, IF A CUSTOMER WANTS TO PROGRAM SOME NEW KEYS, S/HE SHOULD GO TO THE DEALER TAKING ALL THE KEYS S/HE WANTS TO ENABLE.**

The immobilizer operation mode is indicated by a warning light (1) placed on the instrument panel:

- Immobiliser off, indicator light off.
- Immobiliser armed, indicator light flashing.
- Key not recognised, indicator lamp flashing rapidly.

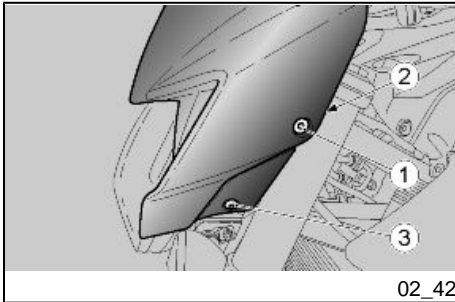

## Fairings (02\_42)

### WINDSHIELD REMOVAL

- Rest the vehicle on its stand.
- Working on both sides, undo and remove the top screw (1) retrieving the nut from inside (2).

- Working on both sides, undo and remove the bottom screw (3).
- Remove the windshield by easing it out from the headlamp.

### Locking torques (N\*m)

#### Windshield screws

2 Nm (1.47 lbf ft)

## Opening the saddle (02\_43, 02\_44, 02\_45)

- Rest the vehicle on its stand.
- Insert the key (1) in the lock.
- Turn the key (1) anticlockwise, slide it off and lift the saddle (2).

There is a useful document / toolkit compartment in the vehicle tail fairing. To get access to it remove the saddle (2).

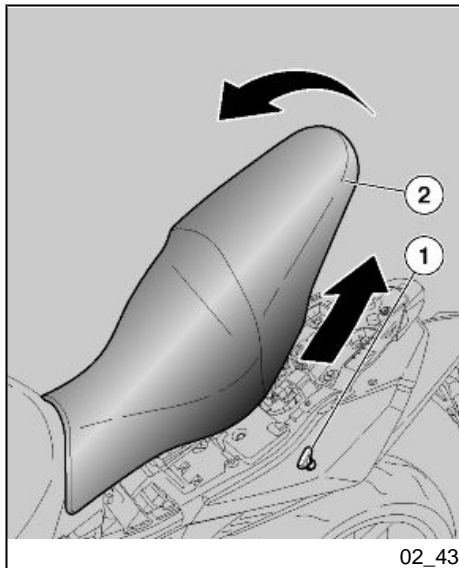

### To lock the saddle (2):

- Position the saddle (2) until the front retainers are correctly inserted.
- Push the centre of the saddle (2), where the rear retainers are, in order to insert them correctly.
- Press the saddle (2), pushing it forward, to trip the lock.

### CAUTION

**BEFORE LOWERING AND LOCKING THE SADDLE, CHECK THAT THE KEY HAS NOT BEEN LEFT IN THE GLOVEBOX / TOOL KIT COMPARTMENT.**

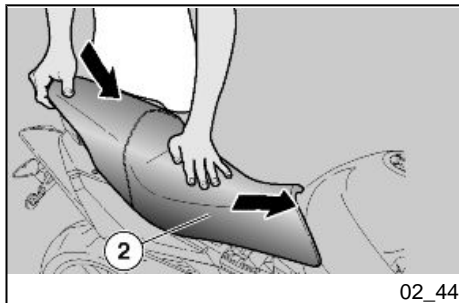

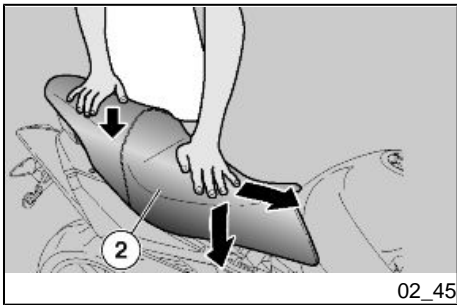

**BEFORE SETTING OFF, MAKE SURE THAT THE SADDLE IS CORRECTLY LOCKED INTO POSITION.**

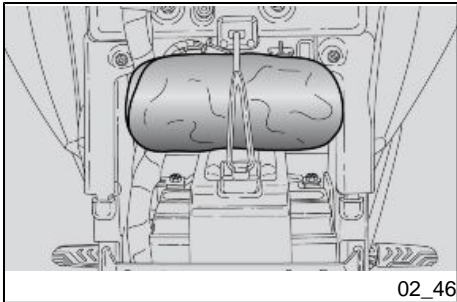

### **Glove/tool kit compartment (02\_46)**

**To get access to the glove-box / toolkit:**

- Remove the saddle

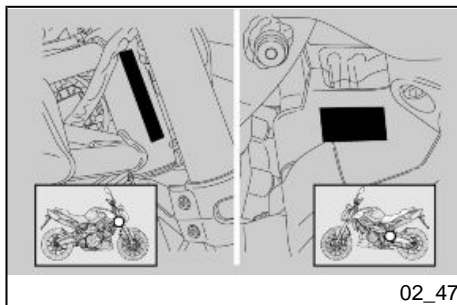

02\_47

## Identification (02\_47)

Write down the chassis and engine number in the specific space in this booklet. The chassis number is handy when purchasing spare parts.

### CAUTION



**CHANGING THE IDENTIFICATION CODE IS A CRIME THAT MAY BE PUNISHED WITH SERIOUS CRIMINAL CHARGES. FURTHERMORE, THE LIMITED WARRANTY FOR NEW VEHICLES WILL BE CANCELLED IF THE VEHICLE IDENTIFICATION NUMBER (VIN) HAS BEEN MODIFIED OR CANNOT BE QUICKLY DETERMINED.**

### CHASSIS NUMBER

The chassis number is stamped on the right side of the headstock.

Chassis No. ....

### ENGINE NUMBER

The engine number is printed on the base of the engine crankcase, left hand side.

Engine No. ....



# SHIVER 750 - SHIVER 750 ABS



**Chap. 03**  
**Use**

## Checks (03\_01)

### CAUTION



**BEFORE RIDING, ALWAYS PERFORM A PRELIMINARY CHECK OF THE VEHICLE TO ENSURE CORRECT AND SAFE OPERATION. FAILURE TO DO SO MAY LEAD TO SERIOUS PERSONAL INJURY OR DAMAGE TO THE VEHICLE. DO NOT HESITATE TO CONTACT AN OFFICIAL Aprilia DEALER IF YOU DO NOT UNDERSTAND HOW SOME CONTROLS WORK OR IF A MALFUNCTION IS DETECTED OR SUSPECTED. CHECKING TAKES VERY LITTLE TIME BUT CONSIDERABLY INCREASES SAFETY.**

### CAUTION

**ACCORDING TO THE TIME ELAPSED FROM THE MOMENT THE KEY IS SET TO "KEY ON" UNTIL THE ENGINE STARTS, THE STOP LIGHT CAN BE ACTIVATED FOR ABOUT HALF A SECOND OR NOT.**

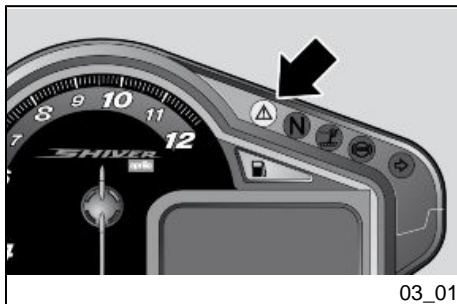

This vehicle has been programmed to indicate in real time any operation failure stored in the electronic control unit memory.

Every time the ignition switch is turned to "KEY ON", the alarm LED warning light turns on for about three seconds on the instrument panel.



## **PRE-RIDE CHECKS**

Front and rear disc brake	Check for proper operation. Check brake lever empty travel and brake fluid level. Check for leaks. Check brake pads for wear. If necessary top-up with brake fluid.
Throttle grip	Check that the throttle functions smoothly and can be fully opened and closed in all steering positions. Adjust and/or lubricate if necessary.
Engine oil	Check and/or top-up as required.
Wheels/ tyres	<p>Check that tyres are in good conditions. Check inflation pressure, tyre wear and potential damage.</p> <p>Remove any possible strange body that might be stuck in the tread design.</p>
Brake levers	<p>Check they function smoothly.</p> <p>Lubricate the joints and adjust the travel if necessary.</p>
Clutch	Check for proper operation. Check clutch lever free play and fluid level. Check for leaks. Top-up the fluid if necessary; the clutch must work without gripping and/or sliding.

Steering	Check that the rotation is uniform, smooth and there are no signs of clearance or slackness.
Side stand / Centre stand OPTIONAL	<p>Check it works properly. Check that there is no resistance when the side stand is pulled up and down and that the spring tension makes it snap back to its rest position.</p> <p>Lubricate couplings and joints if necessary.</p> <p>Check the safety switch for correct operation.</p>
Clamping elements	<p>Check that the clamping elements are not loose.</p> <p>Adjust or tighten them as required.</p>
Drive chain	Check it for backlash.
Fuel tank	<p>Check the coolant level and refill if necessary.</p> <p>Check the circuit for leaks or obstructions.</p> <p>Check that the tank cap closes correctly.</p>
Coolant	Fluid level inside the expansion tank should be between the ' <b>FULL</b> ' and ' <b>LOW</b> ' reference marks.
Engine stop switch (ON - OFF)	Check function.

Lights, warning lights, horn, rear stop light switch and electrical devices

Check function of horn and lights. Replace bulbs or repair any faults noted.

Tone wheels

Check that the tone wheels are perfectly clean and in good conditions.

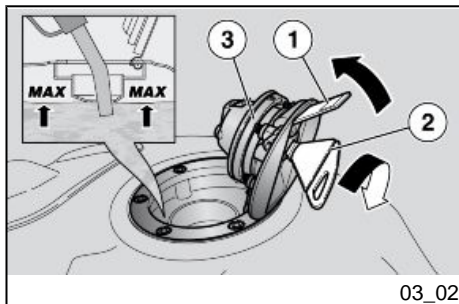

## Refuelling (03\_02)

To refuel:

- Lift the cover (1).
- Introduce the key (2) in the fuel tank cap lock (3).
- Turn the key clockwise, pull and open the fuel tank lid.
- Refuel.

### CAUTION



**DO NOT ADD ADDITIVES OR ANY OTHER SUBSTANCES TO THE FUEL.**

**WHEN USING A FUNNEL, ENSURE THAT IT IS PERFECTLY CLEAN.**



**WHEN FILLING THE TANK COMPLETELY, DO NOT FILL BEYOND THE LOWER EDGE OF THE RECESS (SEE FIGURE).**

**WHEN REFUELLING, AVOID FUEL LEAKS THAT MAY CAUSE DAMAGES TO PROPERTIES AND/OR PEOPLE AND FIRE HAZARD.**

**DURING REFUELLING, AVOID THE USE OF ELECTRIC DEVICES AND/OR MOBILE PHONES, BECAUSE FUEL VAPOURS MAY CAUSE DAMAGE TO OBJECTS AND/OR PERSONAL INJURIES.**

### **Characteristic**

#### **Fuel (reserve included)**

15 l (3.30 UKgal; 3.96 USgal)

#### **Fuel reserve**

3 l (0.66 UKgal; 0.79 USgal)

#### **after refuelling:**

- The fuel cap may only be refitted with the key (2) inserted.
- Once the key (2) is inserted, press the cap to close it again.
- Remove the key (2).
- Close the cover (1).



**MAKE SURE THE CAP IS TIGHTLY CLOSED.**

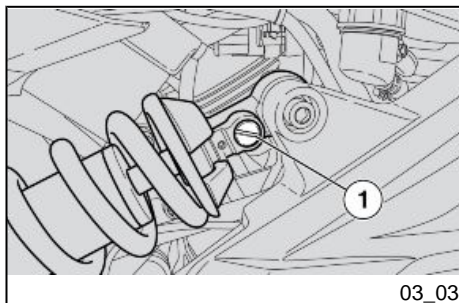

03\_03

## Rear shock absorbers adjustment (03\_03, 03\_04, 03\_05)

The rear suspension consists of a spring-shock absorber unit linked to the frame via uniball joints.

To adjust the setting, the shock absorber is fitted with a set screw (1) that adjusts the hydraulic rebound damping, a ring nut that adjusts the spring preloading (2) and a locking ring nut (3).

### CAUTION

**CARRY OUT MAINTENANCE OPERATIONS AT HALF THE INTERVALS RECOMMENDED IF THE VEHICLE IS USED IN WET OR DUSTY AREAS, OFF ROAD OR FOR SPORTING APPLICATIONS.**

**CHECK AND IF NECESSARY, ADJUST THE REAR SHOCK ABSORBER.**

**THE STANDARD REGULATION OF THE REAR SHOCK ABSORBER IS INTENDED TO SATISFY NORMAL TOUR DRIVING CONDITIONS.**

**IN ANY CASE IT IS POSSIBLE TO INSERT PERSONAL SETTINGS, DEPENDING ON VEHICLE UTILIZATION.**



**WHEN COUNTING THE NUMBER OF CLICKS OF THE ADJUSTER SCREW (1), ALWAYS START FROM THE STIFFEST SETTING (ADJUSTER SCREW FULLY CLOCKWISE).**

**TO AVOID DAMAGE, DO NOT FORCE THE ADJUSTER SCREWS (1) BEYOND THE RESPECTIVE END OF TRAVEL ON EITHER SIDE.**

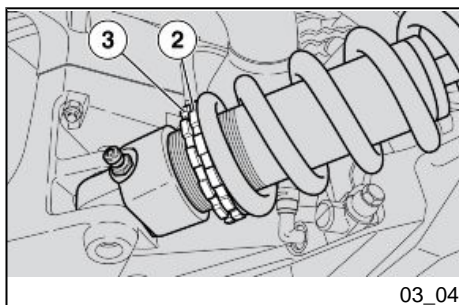

03\_04

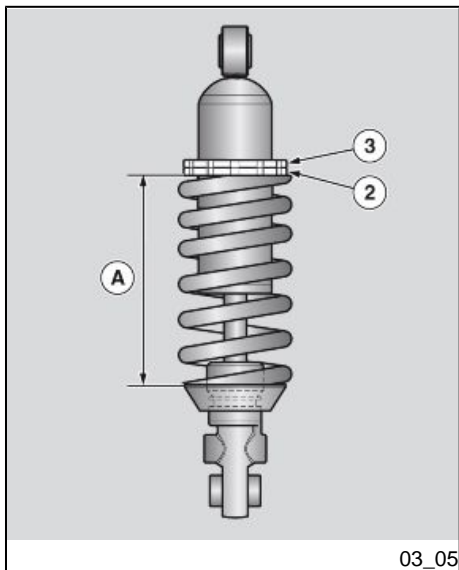

- Using the specific spanner, unscrew the locking ring nut (3).
- Operate on the set ring nut (2) to adjust the spring (A) preloading.
- Once the adjustment is done, screw the ring nut (3).
- Turn the (1) screw to adjust the shock absorber hydraulic rebound damping.



**SET SPRING PRELOADING AND SHOCK ABSORBER REBOUND DAMPING ACCORDING TO THE VEHICLE USE CONDITIONS.**

**IF THE SPRING PRELOADING IS INCREASED, IT IS NECESSARY TO INCREASE THE REBOUND DAMPING ACCORDINGLY TO AVOID SUDDEN JERKS WHEN RIDING.**

**IF NECESSARY, TAKE YOUR VEHICLE TO AN Official Aprilia Dealer. TRY RIDING THE VEHICLE ON THE STREET UNTIL THE OPTIMUM ADJUSTMENT IS OBTAINED.**

#### **REAR SHOCK ABSORBER ADJUSTMENT TABLE**

Rear shock absorber adjustment: rider only / standard adjustment (SOFT setting)	Shock absorber preloading: spring length 16.7 cm (6.57 in)  Hydraulic brake (clicks from fully closed): 12
---	--

Rear shock absorber adjustment: rider + luggage or rider + passenger (MEDIUM setting)	Shock absorber preloading: screw 4 turns (clockwise) with reference to SOFT adjustment
---	--

Hydraulic brake (clicks from fully closed): 9

Rear shock absorber adjustment: rider + passenger + luggage (HARD setting)

Shock absorber preloading: screw 6/7 turns (clockwise) with reference to SOFT adjustment

Hydraulic brake (clicks from fully closed): 6/7

## Front fork adjustment (03\_06)

### CAUTION

**THIS FORK CANNOT BE ADJUSTED.**

- Operating the front brake lever, press the handlebar repeatedly to send the fork fully down. The shock absorber should compress and extend smoothly with no signs of oil leakage on the stanchions.
- Check the tightening of all the elements and the correct operation of the front and rear suspension joints.

### CAUTION

**PLEASE CONTACT AN Official Aprilia Dealer TO HAVE THE FRONT FORK OIL CHANGED AND ITS OIL SEALS REPLACED.**

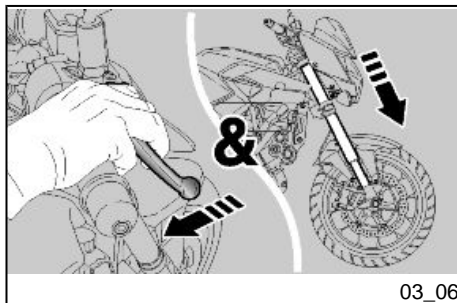

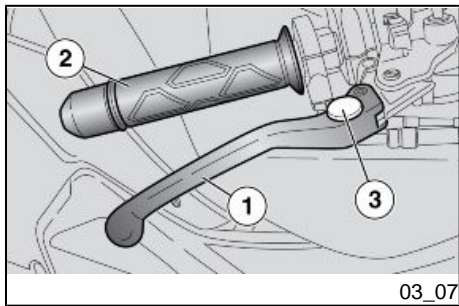

### Justering af greb til forbremse (03\_07)

The distance between the end of the lever (1) and the handgrip (2) can be adjusted by rotating the set screw (3).

The MAX and MIN clicks correspond to a lever end-handgrip distance of about 116 mm (4.57 in) and 98 mm (3.86 in) respectively.

- Push the control lever (1) forward and turn the set screw (3) until the lever (1) is at the desired distance.

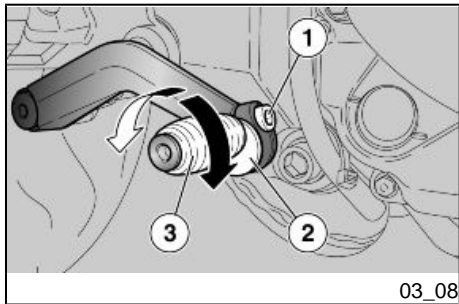

### Rear brake pedal adjustment (03\_08)

The control levers have been ergonomically fitted when assembling the vehicle.

If necessary, the position of the levers can be personalised.

- Rest the vehicle on its stand.
- Partially undo the screw (1).
- Turn the cam (2) until the adequate position for the pedal (3) is obtained.
- Tighten the screw (1) and check the cam is stable in position.

#### CAUTION

**TO ADJUST THE BRAKE LEVER CLEARANCE, CONTACT AN OFFICIAL Aprilia DEALER. IF YOU ARE QUALIFIED EXPERTS REFER TO THE INSTRUCTIONS IN THIS WORKSHOP BOOKLET THAT CAN ALSO BE BOUGHT AT ANY OFFICIAL Aprilia DEALER.**



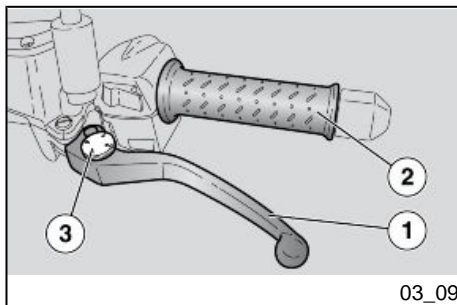

## Clutch lever adjustment (03\_09)

The distance between the end of the lever (1) and the handgrip (2) can be adjusted by rotating the set screw (3).

The MAX and MIN clicks correspond to a lever end-handgrip distance of about 116 mm (4.57 in) and 98 mm (3.86 in) respectively.

- Push the control lever (1) forward and turn the set screw (3) until the lever (1) is at the desired distance.

## Running in

Running in is essential to ensure the durability of the vehicle. During the first 1000 Km (621.37 mi), observe the following rules to ensure the reliability and performance of the vehicle throughout its lifetime:

- Avoid full throttle starts and hard acceleration;
- Avoid hard or prolonged braking;
- Do not ride for prolonged periods at sustained high speed; preferably ride the motorcycle on varied routes with frequent, gentle acceleration and deceleration;
- Ride prudently to gradually gain familiarity with the motorcycle, testing progressively higher throttle apertures only as you gain confidence

### CAUTION

**THE FULL PERFORMANCE OF THE VEHICLE IS ONLY AVAILABLE AFTER THE SERVICE AT THE END OF THE RUNNING IN PERIOD.**

### Follow these guidelines:

- Do not twist the throttle grip abruptly and completely when the engine is working at a low revs, either during or after run-in.

- During the first 100 Km (62.14 miles) use the brakes gently, avoiding sudden or prolonged braking. That is to permit the adequate adjustment of the pad friction material to the brake discs.



**AFTER THE SPECIFIED MILEAGE, TAKE YOUR VEHICLE TO AN Official Aprilia Dealer FOR THE CHECKS INDICATED IN THE "AFTER-RUN-IN" TABLE IN THE SCHEDULED MAINTENANCE SECTION TO AVOID INJURING YOURSELF, OTHERS AND /OR DAMAGING THE VEHICLE.**

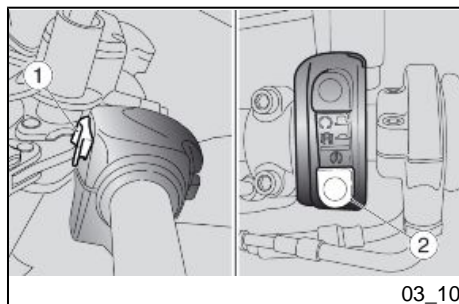

03\_10

### Starting up the engine (03\_10, 03\_11, 03\_12, 03\_13, 03\_14, 03\_15)

This vehicle is extremely powerful and must be used carefully and driven with caution and respect for its power and potential.

Do not carry objects in the top fairing (between the handlebar and the instrument panel) so that the handlebar can turn freely and the instrument panel is visible at all times.



**EXHAUST FUMES CONTAIN CARBON MONOXIDE, AN EXTREMELY HARMFUL SUBSTANCE IF INHALED.**

**NEVER START THE ENGINE IN A CLOSED OR INSUFFICIENTLY VENTILATED SPACE.**



**FAILURE TO OBSERVE THIS WARNING COULD LEAD TO UNCONSCIOUSNESS AND EVEN DEATH DUE TO SUFFOCATION.**

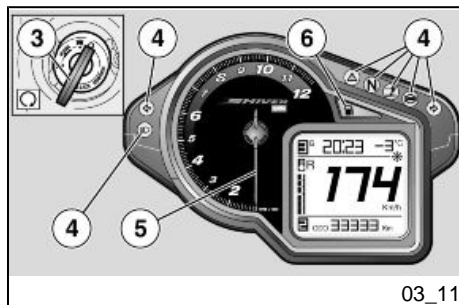

03\_11

**CAUTION**

**WITH THE SIDE STAND LOWERED, THE ENGINE MAY ONLY BE STARTED WITH THE GEARBOX IN NEUTRAL. IF YOU ATTEMPT TO ENGAGE A GEAR IN THIS CONDITION THE ENGINE WILL STOP.**

**WITH THE SIDE STAND RETRACTED, THE ENGINE MAY BE STARTED WITH THE GEARBOX IN NEUTRAL OR WITH GEAR ENGAGED AND THE CLUTCH LEVER PRESSED.**

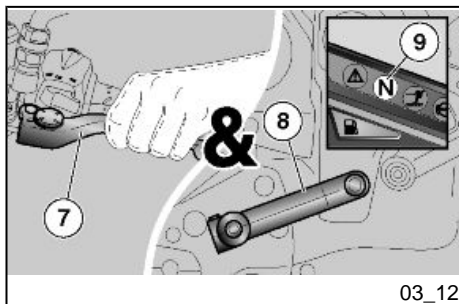

- Get onto the bike in riding position.
- Make sure that the stand has been fully retracted.
- Make sure the light switch (1) is set to the low beam light position.
- Set the engine stop switch (2) to RUN.
- Turn the key (3) and set the ignition switch to ON.

At this stage:

- The multifunction display shows the ignition screen for 2 seconds.
- On the instrument panel, all warning lights (4) and the backlighting are on for 2 seconds.
- The rpm indicator (5) goes to the bottom of the scale and after 3 seconds, it goes back to the minimum value.
- The current value is instantly indicated on the instrument panel during regular vehicle riding.



**IF THE LOW FUEL WARNING LIGHT (6) ON THE INSTRUMENT PANEL TURNS ON, REFUEL THE VEHICLE AT ONCE.**



**THE OVERREVING THRESHOLD IN NEW VEHICLES IS SET TO 6000 RPM. RAISE THIS THRESHOLD AS YOU GET USED TO THE VEHICLE.**

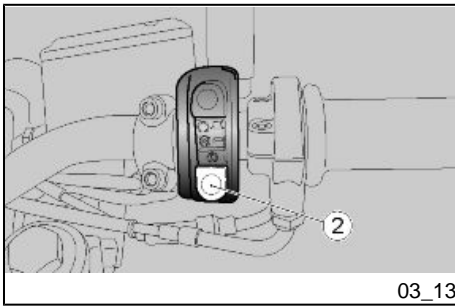

- Block at least one wheel by operating one brake lever.
- Operate the clutch lever (7) completely and set the gearshift lever (8) to neutral (green warning light "N" (9) on).
- There is a starter on the vehicle, controlled by the control unit, that starts working automatically whenever necessary (cold start).



**TO AVOID EXCESSIVE BATTERY CONSUMPTION, DO NOT HOLD DOWN THE STARTER BUTTON (2) MORE THAN TEN SECONDS.**

**IF THE ENGINE FAILS TO START AFTER THIS TIME, WAIT TEN SECONDS AND PRESS THE STARTER BUTTON (2) AGAIN.**

**PRESS THE STARTER BUTTON (2) BUT DO NOT ACCELERATE, AND RELEASE IT AS SOON AS THE ENGINE STARTS.**

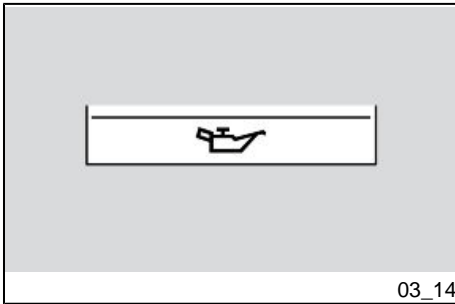

**AVOID PRESSING THE STARTER BUTTON (2) WHEN THE ENGINE HAS ALREADY STARTED, AS THIS COULD DAMAGE THE STARTER MOTOR.**

**IF THE ENGINE OIL PRESSURE ICON IS DISPLAYED AND THE GENERAL WARNING LIGHT IS ON, THIS MEANS THAT THE OIL PRESSURE IN THE CIRCUIT IS TOO LOW.**

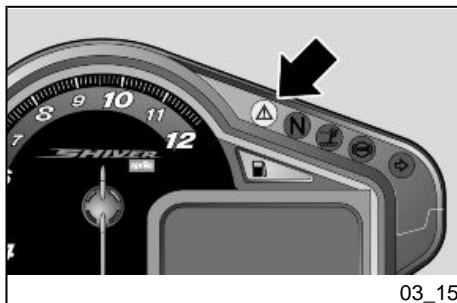

- Engage at least one brake lever and do not accelerate until you set off.



**DO NOT SET OFF SUDDENLY WHEN THE ENGINE IS COLD. RIDE AT LOW SPEED FOR SEVERAL KILOMETRES. THIS WILL ALLOW THE ENGINE TO WARM UP AND REDUCE POLLUTING EMISSIONS AND FUEL CONSUMPTION.**



**IF THE WORD "SERVICE" IS SHOWN ON THE (MULTIFUNCTION) DISPLAY DURING REGULAR ENGINE OPERATION, THIS MEANS THAT THE ELECTRONIC CONTROL UNIT HAS DETECTED A PROBLEM.**

### Ride by wire

The vehicle is fitted with an innovative throttle control system, called RIDE BY WIRE, which ensures optimum engine performance, at all times, taking into account the rider's demand, the general operating conditions plus the external conditions (atmospheric pressure, temperature). If compared with traditional injection systems, it also allows an electronic control of the throttle, thus replacing the traditional cable. When riding at high altitudes, the RIDE BY WIRE system offsets the unavoidable loss of power (1% every 100 metres of slope due to the reduced concentration of oxygen in the air) by opening the throttle bodies. Therefore, the engine performance when torque demand is requested by means of the throttle is the same as when riding on level ground, thus shifting the characteristic power reduction to the highest speeds. As a result, throttles are fully open but the throttle grip is not fully twisted; therefore, in case the throttle grip is further and fully twisted, the vehicle performance will not be further enhanced.

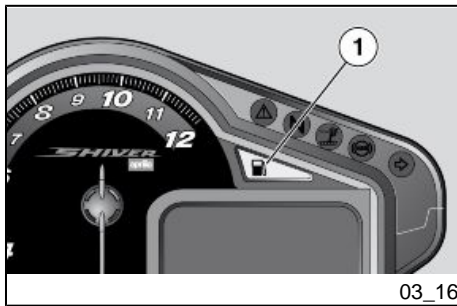

03\_16

## Moving off / riding (03\_16, 03\_17, 03\_18, 03\_19, 03\_20, 03\_21, 03\_22)

### CAUTION

IF, WHILE RIDING, THE LOW FUEL WARNING LIGHT (1) ON THE INSTRUMENT PANEL TURNS ON, IT MEANS THERE IS STILL SOME FUEL LEFT.

REFUEL AS SOON AS POSSIBLE.

### CAUTION

WHEN TRAVELLING WITHOUT PASSENGERS, MAKE SURE THE PASSENGER FOOTRESTS ARE FOLDED UP.

### CAUTION

PASSENGERS MUST BE SUITABLY INSTRUCTED ON HOW TO BEHAVE TO PREVENT DANGEROUS SITUATIONS WHEN RIDING.

BEFORE SETTING OFF, MAKE SURE THE STAND HAS BEEN COMPLETELY RETRACTED TO ITS POSITION.

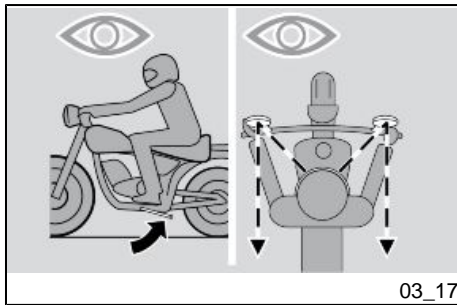

03\_17

### To start:

- Turn on the engine.
- Adjust the inclination of the rear-view mirrors to ensure proper visibility.

### CAUTION



WITH THE VEHICLE AT A STANDSTILL, PRACTICE USING THE REAR-VIEW MIRRORS. THE MIRRORS ARE CONVEX, SO OBJECTS MAY SEEM FARTHER AWAY THAN THEY REALLY ARE. THESE MIRRORS OFFER A WIDE-ANGLE VIEW AND ONLY EXPERIENCE HELPS YOU JUDGE THE DISTANCE SEPARATING YOU AND THE VEHICLE BEHIND.

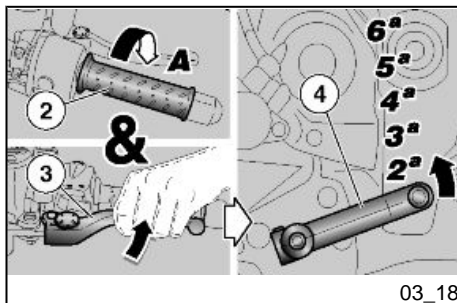

- With throttle grip (2) closed (**Pos. A**) and engine at idle, operate the clutch lever (3).
- Push the gearbox lever (4) downward to select the first gear.
- Release the clutch lever (activated during start-up).

#### CAUTION

**WHEN TURNING OFF THE VEHICLE, DO NOT RELEASE THE CLUTCH TOO QUICKLY OR SUDDENLY, AS THIS COULD CAUSE THE ENGINE TO STOP OR THE VEHICLE TO REAR UP ON THE BACK WHEEL. DO NOT ACCELERATE SUDDENLY WHEN RELEASING THE CLUTCH FOR THE SAME REASON.**

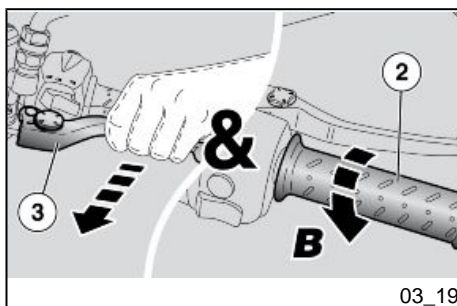

- Slowly release the clutch lever (3) and at the same time accelerate by slightly twisting the throttle grip (2) (**Pos. B**).

The vehicle starts moving forward.

- For the first kilometres travelled, limit the speed in order to warm up the engine.



**DO NOT EXCEED THE MAXIMUM RECOMMENDED ENGINE SPEED.**

- Accelerate gradually by twisting the throttle grip (2) (**Pos. B**) without exceeding the recommended rpm.

**To engage the second gear:**



**RIDE IN THE CORRECT GEAR AND SPEED FOR THE CONDITIONS.  
DO NOT OPERATE THE ENGINE AT A TOO LOW RPM LEVEL.**

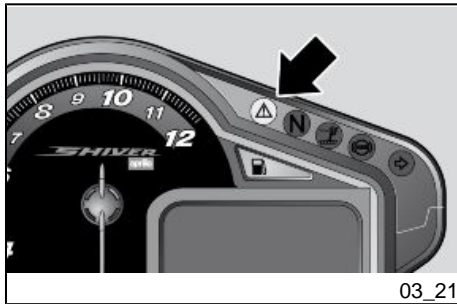
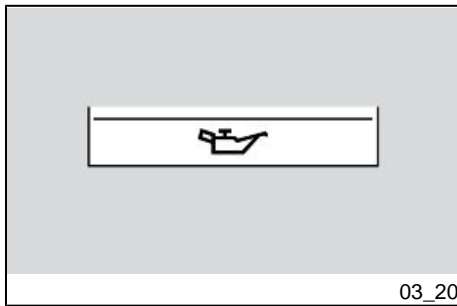

- Release the throttle grip (2) (**Pos. A**), operate the clutch lever (3), lift the gearshift lever (4), release the clutch lever (3) and accelerate.
- Repeat the last two operations and engage a higher gear.



**IF THE ENGINE OIL PRESSURE ICON IS DISPLAYED AND THE GENERAL WARNING LIGHT IS ON DURING REGULAR ENGINE OPERATION, THIS MEANS THAT THE ENGINE OIL PRESSURE IN THE CIRCUIT IS TOO LOW.**

**IF THIS OCCURS, STOP THE ENGINE AND CONTACT AN APRILIA Official Dealer.**

**SHIFTING FROM A HIGHER TO A LOWER GEAR, CALLED "DOWNSHIFT", IS CARRIED OUT:**

- When riding downhill and when braking, in order to increase the braking power by using engine compression.
- When going uphill, when the engaged gear does not suit the speed (high gear, moderate speed) and the number of engine revs falls.

#### **CAUTION**

**DOWNSHIFT ONE GEAR AT A TIME; WHEN SHIFTING TO A LOWER GEAR, DOWNSHIFTING MORE THAN ONE GEAR AT A TIME COULD OVERREV THE ENGINE; THAT IS, THE MAXIMUM RPM VALUE PERMITTED FOR THE ENGINE COULD BE EXCEEDED.**



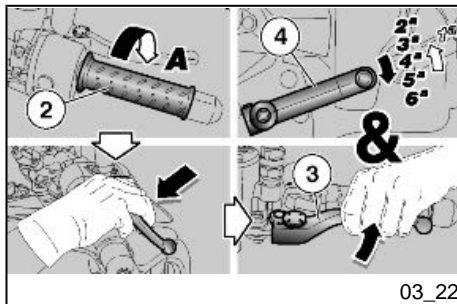

- Release the throttle grip (2) (**Pos. A**)
- If necessary, pull the brake levers gently and reduce speed.
- Operate the clutch lever (3) and lower the gearshift lever (4) to engage a lower gear.
- Release the brake levers when it is operated.
- Release the clutch lever (3) and accelerate moderately.



**IF AN ENGINE OVERHEATING ALARM INDICATOR IS SHOWN ON THE MULTI-FUNCTION DIGITAL DISPLAY, STOP THE VEHICLE AND LET THE ENGINE RUN AT 3000 rpm FOR ABOUT TWO MINUTES, SO THAT THE COOLANT FLOWS REGULARLY IN THE SYSTEM; THEN SET THE ENGINE STOP SWITCH TO "OFF" AND CHECK THE COOLANT LEVEL.**

**IF THE TEMPERATURE INDICATOR CONTINUES FLASHING AFTER CHECKING THE COOLANT LEVEL, CONTACT AN OFFICIAL APRILIA DEALER.**

**DO NOT TURN THE IGNITION KEY TO "KEY OFF", BECAUSE THE COOLING FANS WOULD STOP REGARDLESS OF THE COOLANT TEMPERATURE, WHICH WOULD CAUSE A FURTHER TEMPERATURE RISE.**

**IF THE GENERAL WARNING LIGHT ACTIVATES ON THE INSTRUMENT PANEL DURING REGULAR ENGINE OPERATION, THIS MEANS THAT SOME FAILURES HAVE BEEN DETECTED.**

**IN MANY CASES THE ENGINE WILL CONTINUE TO OPERATE WITH LIMITED PERFORMANCE; IMMEDIATELY CONTACT AN Official APRILIA Dealer.**

**IN ORDER TO AVOID CLUTCH OVERHEATING, SHUT THE ENGINE OFF AS SOON AS POSSIBLE ONCE THE VEHICLE HAS STOPPED AND AT THE SAME TIME THE GEAR IS ENGAGED AND THE CLUTCH LEVER OPERATED.**



**OPERATING ONLY EITHER THE FRONT OR THE REAR BRAKE SIGNIFICANTLY REDUCES BRAKING POWER AND A WHEEL MAY GET BLOCKED RESULTING IN LACK OF GRIP.**

**WHEN STOPPING WHILE TRAVELLING UPHILL, CLOSE THE THROTTLE COMPLETELY AND ONLY USE THE BRAKES TO HOLD THE VEHICLE IN POSITION.**

**USING THE ENGINE TO HOLD THE VEHICLE ON A HILL MAY CAUSE THE CLUTCH TO OVERHEAT.**

**BRAKING CONTINUOUSLY WHILE GOING DOWNHILL MAY RESULT IN FRICTION GASKET OVERHEATING AND CONSEQUENTLY IN POOR BRAKING.**

**TAKE ADVANTAGE OF THE ENGINE COMPRESSION AND SHIFT UP GEARS USING THE BRAKES ALTERNATIVELY.**

**NEVER RIDE WITH THE ENGINE OFF WHEN GOING DOWNHILL.**

**WHEN RIDING ON WET SURFACES OR WITH POOR GRIP (SNOW, ICE, MUD, ETC.) RIDE AT A MODERATE SPEED AVOIDING SUDDEN BRAKING OR MANOEUVRES THAT MAY LEAD TO LACK OF GRIP AND CONSEQUENTLY TO FALLS.**

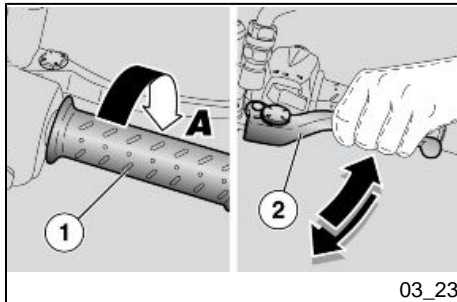

### **Stopping the engine (03\_23)**

- Release the throttle grip (1) (**Pos. A**), brake gradually and at the same time "downshift" gears to slow down.

**Once the speed is reduced, before stopping the vehicle:**

- Operate the clutch lever (2) so that engine does not shut off.

**When the vehicle is at a standstill:**

- Set the gearshift lever in neutral (green "N" indicator light lit).
- Release the clutch lever.
- While at a temporary halt, keep at least one of the vehicle brakes held.

**CAUTION**

**WHENEVER POSSIBLE, AVOID ROUGH BRAKING, SUDDEN DECELERATION AND BRAKING IN EXCESS.**

**Parking**

It is very important to select an adequate parking spot, in compliance with road signals and the guidelines described below.

**CAUTION**

**PARK ON SAFE AND LEVEL GROUND TO PREVENT THE VEHICLE FROM FALLING.**

**DO NOT LEAN THE VEHICLE AGAINST A WALL OR LAY IT ON THE GROUND.**

**ENSURE THAT THE VEHICLE AND, IN PARTICULAR, PARTS OF THE VEHICLE WHICH MAY BECOME HOT (ENGINE, OIL RADIATOR AND LINES, EXHAUST SYSTEM, BRAKE DISCS) ARE NOT A HAZARD TO PERSONS OR CHILDREN. DO NOT LEAVE YOUR VEHICLE UNATTENDED WITH THE ENGINE ON OR THE KEY IN THE IGNITION SWITCH.**

**CAUTION**

**IF THE VEHICLE FALLS OR IS ON A STEEP INCLINE FUEL CAN LEAK.**

**FUEL USED TO DRIVE INTERNAL COMBUSTION ENGINES IS HIGHLY FLAMMABLE AND CAN BECOME EXPLOSIVE UNDER CERTAIN CONDITIONS.**



**DO NOT REST THE RIDER OR PASSENGER WEIGHT ON THE SIDE STAND.**

## Catalytic silencer

The vehicle has a silencer with a "platinum - palladium - rhodium three-way" metal catalytic converter.

This device oxidises the CO (carbon monoxide) producing carbon dioxide, and the UHC (unburned hydrocarbons) producing water vapour and reduces NOx (nitrogen oxide) producing oxygen and nitrogen present in the exhaust fumes.



**DO NOT PARK THE VEHICLE NEAR DRY BRUSHWOOD OR IN PLACES EASILY ACCESSIBLE BY CHILDREN BECAUSE THE CATALYTIC CONVERTER REACHES HIGH TEMPERATURES DURING VEHICLE OPERATION; FOR THIS REASON, PAY UTMOST ATTENTION AND DO NOT TOUCH IT UNTIL IT HAS COMPLETELY COOLED DOWN.**



**DO NOT USE LEADED PETROL AS IT CAUSES IRREPARABLE DAMAGE TO THE CATALYTIC CONVERTER.**

Vehicle owners are warned that the law may prohibit the following:

- the removal of any device or element belonging to a new vehicle or any other action by anyone leading to render it non-operating, if not for maintenance, repair or replacement reasons, in order to control noise emission before the sale or delivery of the vehicle to the ultimate buyer or while it is used;
- using the vehicle after that device or element has been removed or rendered non-operating.

Check the muffler/exhaust silencer and the silencer pipes, make sure there are no signs of rust or holes and that the exhaust system works properly.

If you not an increase in exhaust noise, take your vehicle to an Official **Aprilia Dealer** at once.

#### NOTE

**DO NOT TAMPER WITH THE EXHAUST SYSTEM.**

### Stand (03\_24)

If the side stand must be lowered for any reason (for example after moving the vehicle), proceed as described below:

- Select an appropriate parking area.
- Grasp the left handgrip (1) and place your right hand on the rear upper part of the vehicle (2).
- Lower the side stand with your right foot, and extend it completely (3).
- Tilt the motorcycle until the stand touch the ground.
- Turn the handlebar fully leftwards.

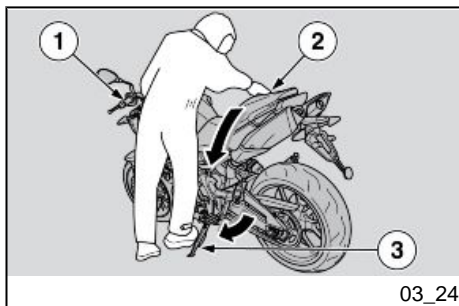

**MAKE SURE THAT THE GROUND ON WHICH THE MOTORCYCLE IS PARKED IS FIRM, EVEN AND FREE OF OBSTACLES.**

### Suggestion to prevent theft

#### CAUTION

**WHEN USING A DISC LOCKING DEVICE, PAY UTMOST ATTENTION TO REMOVE IT BEFORE RIDING. FAILURE TO OBSERVE THIS WARNING MAY CAUSE SERIOUS DAMAGE TO THE BRAKING SYSTEM AND ACCIDENTS WITH CONSEQUENT PHYSICAL INJURIES OR EVEN DEATH.**

NEVER leave the ignition key in the lock and always use the steering lock. Park the vehicle in a safe place such as a garage or a place with guards. Whenever possible, use an additional anti-theft device. Make sure all vehicle documents are in order and the road tax paid. Write down your personal details and telephone number on this page to help identifying the owner in case of vehicle retrieval after a theft.

LAST NAME: .....

NAME: .....

ADDRESS: .....

TELEPHONE NO.: .....

#### **WARNING**

**IN MANY CASES, STOLEN VEHICLES CAN BE IDENTIFIED BY DATA IN THE USE / MAINTENANCE BOOKLET**

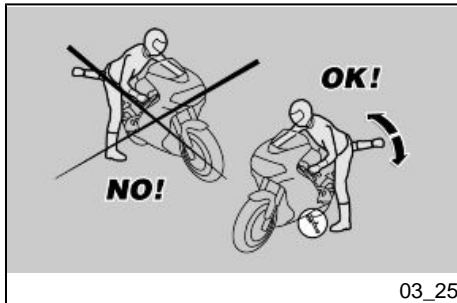

#### **Basic safety rules (03\_25, 03\_26, 03\_27, 03\_28, 03\_29)**

The following recommendations should receive your maximum attention, because they are provided to increase your safety, and decrease damage to people, things and vehicles, in the case of a fall of the rider or passenger from the vehicle and/or from the fall or overturning of the vehicle.

Mounting and dismounting the vehicle should always be performed with total freedom of movement and with the hands free of all objects. (i.e.- objects, helmet, gloves, or glasses).

Mount and dismount only on the left side of the vehicle, and only with the side stand lowered.

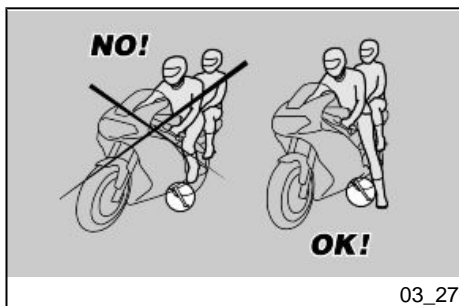
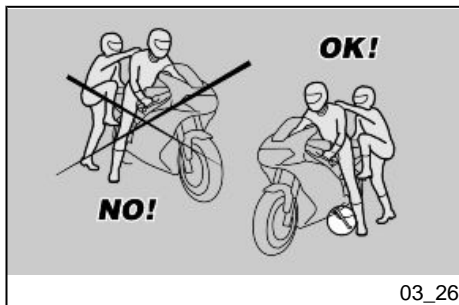

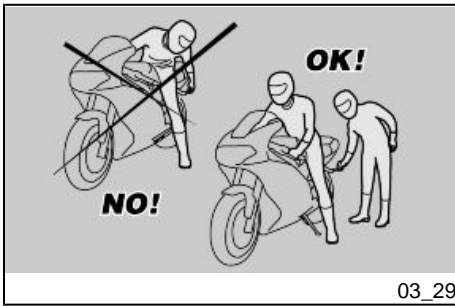

The stand is designed to support the weight of the vehicle and a small additional weight, which does not include the rider and passenger.

Mounting into driving position, with the side stand in place, is permitted only to prevent the possibility of the vehicle falling or overturn, and does not indicate the possibility for the rider and passenger's weight to be placed on the side stand.

During mounting and dismounting the vehicle's weight can cause a loss of balance, with consequent loss of equilibrium and the possibility of falling or overturning.

#### **CAUTION**

**THE RIDER SHOULD ALWAYS BE THE FIRST TO MOUNT AND THE LAST TO DISMOUNT FROM THE VEHICLE, AND SHOULD CONTROL THE STABILITY AND EQUILIBRIUM OF THE VEHICLE WHILE THE PASSENGER IS MOUNTING AND DISMOUNTING**

In any case, the passenger should mount and dismount the vehicle using caution to avoid causing the vehicle or the rider to lose balance.

#### **CAUTION**

**THE RIDER TO INSTRUCT THE PASSENGER ABOUT THE PROPER WAY TO MOUNT AND DISMOUNT FROM THE VEHICLE.**

**THE VEHICLE INCLUDES PASSENGER FOOTRESTS WHICH SHOULD BE USED DURING MOUNTING AND DISMOUNTING. THE PASSENGER SHOULD ALWAYS USE THE LEFT FOOTREST FOR MOUNTING AND DISMOUNTING FROM THE VEHICLE.**

**DO NOT DISMOUNT OR EVEN ATTEMPT TO DISMOUNT BY JUMPING OR STRETCHING OUT YOUR LEG IN ORDER TO TOUCH THE GROUND. IN BOTH CASES THE STABILITY AND EQUILIBRIUM OF THE VEHICLE COULD BE COMPROMISED.**



**CAUTION**

**BAGGAGE OR OBJECTS ATTACHED TO THE REAR PART OF THE VEHICLE CAN CREATE AN OBSTACLE DURING MOUNTING AND DISMOUNTING FROM THE VEHICLE.**

**IN ALL CASES, THINK AHEAD AND MOVE YOUR RIGHT LEG CAREFULLY, AS IT WILL HAVE TO AVOID AND CLEAR THE REAR PART OF THE VEHICLE (INCLUDING BAGGAGE AND THE TAIL FAIRING) WITHOUT CAUSING LOSS OF BALANCE.**

**MOUNTING**

- Grip the handlebar properly and mount the vehicle without placing your weight upon the side stand.

**CAUTION**

**IN THE CASE THAT YOU ARE NOT ABLE TO REST BOTH FEET ON THE GROUND, PUT THE RIGHT FOOT ON THE GROUND, (IN THE CASE OF A LOSS OF BALANCE THE LEFT SIDE IS "PROTECTED" BY THE SIDE STAND) AND KEEP YOUR LEFT FOOT READY TO BE POSITIONED.**

- Place both feet on the ground and straighten the vehicle into the driving position, always maintaining its equilibrium.

**CAUTION**

**THE RIDER SHOULD NOT OPEN OR TRY TO OPEN THE PASSENGER FOOTRESTS FROM THE RIDER'S SEAT, AS IT COULD COMPROMISE THE STABILITY AND EQUILIBRIUM OF THE VEHICLE.**

- Have the passenger open the two passenger foot pegs.
- Show the passenger how to mount the vehicle.
- Use your left foot to push on the side stand and make it fully return to its position.

## DISMOUNTING

- Select an appropriate parking spot.
- Stop the vehicle.



**MAKE SURE THAT THE GROUND ON WHICH THE MOTORCYCLE IS PARKED IS FIRM, EVEN AND FREE OF OBSTACLES.**

- Use the heel of your left foot to completely open the side stand.

### CAUTION

**IN THE CASE THAT YOU ARE NOT ABLE TO REST BOTH FEET ON THE GROUND, PUT THE RIGHT FOOT ON THE GROUND, (IN THE CASE OF A LOSS OF BALANCE THE LEFT SIDE IS "PROTECTED" BY THE SIDE STAND) AND KEEP YOUR LEFT FOOT READY TO BE POSITIONED.**

- Place both feet on the ground and keep the vehicle balanced in the driving position.
- Show the passenger how to dismount from the vehicle.



**RISK OF FALLING OR OVERTURNING.**

**MAKE SURE THAT THE PASSENGER HAS DISMOUNTED FROM THE VEHICLE.  
DO NOT PLACE YOUR WEIGHT UPON THE SIDE STAND.**

- Lean the motorcycle until the stand touches the ground.
- Correctly grip the handlebar, and dismount from the vehicle.
- Turn the handlebar completely to the left.

- Place the passenger footrest in its place.

**CAUTION**

**MAKE SURE THE VEHICLE IS STABLE.**



# SHIVER 750 - SHIVER 750 ABS



**Chap. 04**  
**Maintenance**

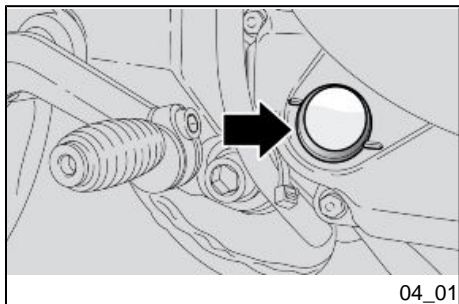

## Engine oil level check (04\_01)

Check the engine oil level frequently.

### NOTE

**CARRY OUT MAINTENANCE OPERATIONS AT HALF THE INTERVALS SPECIFIED IF THE VEHICLE IS USED IN PARTICULAR RAINY OR DUSTY CONDITIONS, OFF ROAD OR FOR TRACK USE.**



**ENGINE OIL LEVEL MUST BE CHECKED WHEN THE ENGINE IS WARM.**

**IF YOU CHECK LEVEL WHEN THE ENGINE IS COLD, OIL LEVEL COULD TEMPORARILY DROP BELOW THE "MIN" MARK.**

**THIS SHOULD NOT BE CONSIDERED A PROBLEM PROVIDED THAT THE ALARM WARNING LIGHT AND THE ENGINE OIL PRESSURE ICON DO NOT TURN ON SIMULTANEOUSLY ON THE DISPLAY.**

### CAUTION

**DO NOT LET THE ENGINE IDLE WITH THE VEHICLE AT A STANDSTILL TO WARM UP THE ENGINE AND OBTAIN THE OPERATING TEMPERATURE OF ENGINE OIL.**

**PREFERABLY CHECK THE OIL AFTER A JOURNEY OF AFTER TRAVELLING APPROXIMATELY 15 Km (10 miles) IN EXTRAURBAN CONDITIONS (ENOUGH TO WARM UP THE ENGINE OIL TO OPERATING TEMPERATURE).**

- Shut off the engine.
- Keep the vehicle upright with both wheels on the ground.
- Check the oil level through the appropriate sight glass on the engine crankcase.

**MAX** = maximum level.

MIN = minimum level

The difference between the "MAX" and "MIN" marks is approx. 600 cm<sup>3</sup> (36.61 cu.in).

- The oil level is correct when it is close to the "MAX" mark.

## Engine oil top-up (04\_02)

### CAUTION



**DO NOT GO BEYOND THE "MAX" AND BELOW THE "MIN" LEVEL MARK TO AVOID SEVERE ENGINE DAMAGE.**

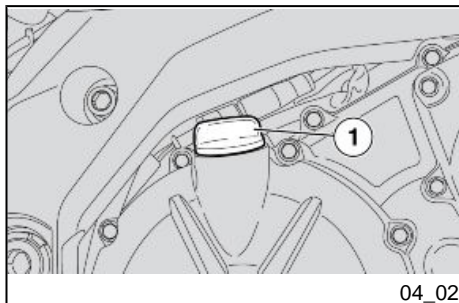

**Fill with engine oil as required:**

- Unscrew and remove the cap (1).

**When using a funnel or any other element, make sure it is perfectly clean.**



**DO NOT ADD ADDITIVES OR OTHER SUBSTANCES TO THE OIL.**

### CAUTION

**USE HIGH-QUALITY 15W - 50 OIL.**

- Top-up the oil in the reservoir until you reach the correct level.

## Engine oil change (04\_03)



**CHANGING ENGINE OIL AND ENGINE OIL FILTER CAN PROVE DIFFICULT IF YOU ARE INEXPERIENCED.**

**CONTACT AN OFFICIAL APRILIA DEALER IF REQUIRED.**

**IF YOU WISH TO PERFORM THESE OPERATIONS YOURSELF, FOLLOW THESE INSTRUCTIONS.**

Check the engine oil level frequently.

**For replacement:**

### **CAUTION**

**HOT OIL IS MORE FLUID AND WILL DRAIN OUT MORE EASILY AND COMPLETELY; IDEAL TEMPERATURE IS REACHED AFTER THE ENGINE HAS RUN FOR ABOUT TWENTY MINUTES.**



**OIL BECOMES VERY HOT WHEN THE ENGINE IS HOT; BE CAREFUL NOT TO GET BURNED WHEN CARRYING OUT THE OPERATIONS DESCRIBED BELOW.**



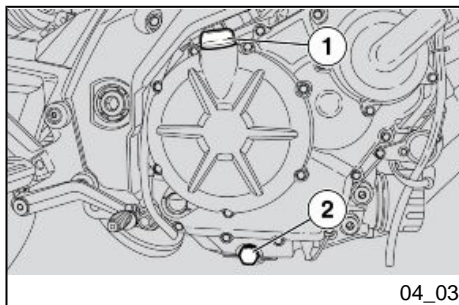

- Use a cloth to wipe off any mud deposit on the area next to the filler plug (1).
- Place a container with + 4000 cm<sup>3</sup> (244 cu.in) capacity under the drainage plug (2).
- Unscrew and remove the drainage plug (2).
- Unscrew and remove the filler plug (1).
- Drain the oil into the container; allow several minutes for oil to drain out completely.
- Replace the sealing washer of the drainage plug (2).
- Remove any metal scrap attached to the drainage plug (2) magnet.
- Screw and tighten the drainage plug (2).

### **Locking torques (N\*m)**

#### **Oil drainage plug - M16x1.5**

*19 Nm (14.01 lbf ft)*

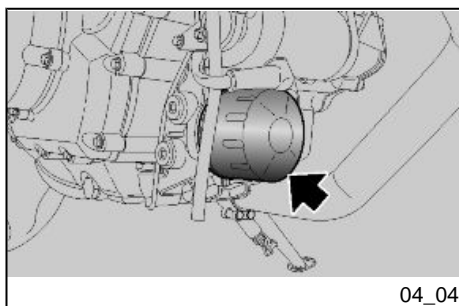

### **Engine oil filter replacement (04\_04, 04\_05)**

Replace the engine oil filter every 20,000 km (12,428 mi) (or each time you change the engine oil).

- Drain off the engine oil completely.
- Remove the engine oil filter.

**In the version with the ABS system, the engine oil filter is under the guard that houses the ABS control unit.**

- Fit a new engine oil filter.

#### **Never reuse an old filter.**

- Fill with engine oil.
- Screw and tighten the oil filling / drainage plugs.
- Start the engine and let it run for several minutes.
- Stop the engine.
- Check engine oil level and top up, if required.

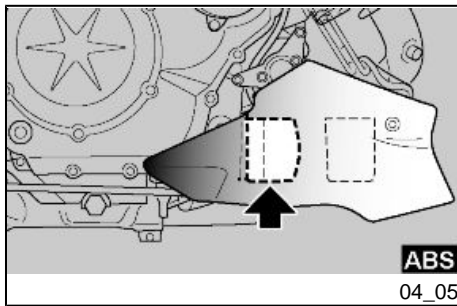

## Tyres

This vehicle is fitted with tyres without inner tubes (Tubeless).



**CHECK TYRE INFLATION PRESSURE REGULARLY, AT LEAST ONCE A MONTH, AT AMBIENT TEMPERATURE.**

**MEASUREMENTS MAY BE INCORRECT IF TYRES ARE WARM.**

**CHECK PRESSURE MAINLY BEFORE AND AFTER LONG TRIPS.**

**IF THE TYRE PRESSURE IS TOO HIGH, UNEVENNESS IN THE ROAD SURFACE WILL NOT BE DAMPED AND WILL BE TRANSMITTED TO THE HANDLEBAR, RESULTING IN AN UNPLEASANTLY HARSH RIDE AND POOR ROAD HOLDING, ESPECIALLY WHEN CORNERING.**

**AN UNDERINFLATED TYRE, ON THE OTHER HAND, WILL EXTEND THE CONTACT PATCH TO INCLUDE A LARGER PORTION OF THE TYRE SIDEWALLS. WHEN THIS IS THE CASE, THE TYRE MIGHT SLIP ON OR BECOME DETACHED FROM THE WHEEL RIM, LEADING TO LOSS OF CONTROL OVER THE VEHICLE.**

**TYRES MAY EVEN DETACH FROM THE WHEEL RIMS UNDER VERY HARD BRAKING.**

**THE VEHICLE MAY EVEN SKID IN A BEND.**

**INSPECT TREAD SURFACE AND CHECK IT FOR WEAR. BADLY WORN TYRES MAY COMPROMISE TRACTION AND HANDLING.**

**REPLACE TYRES WHEN WORN OR IF THERE IS A PUNCTURE IN THE TREAD AREA BIGGER THAN 5 mm (0.197 in).**

**BALANCE WHEELS AFTER A TYRE IS MENDED. USE ONLY TYRE SIZES INDICATED BY THE MANUFACTURER.**

**CHECK THAT THE INFLATION VALVES HAVE THEIR CAPS FITTED TO AVOID UNEXPECTED FLAT TYRES. REPLACEMENT, REPAIR, MAINTENANCE AND BALANCING OPERATIONS ARE HIGHLY IMPORTANT AND SO THEY SHOULD BE CARRIED OUT USING THE SPECIFIC TOOLS AND WITH THE ADEQUATE KNOWLEDGE.**

**IT IS THEREFORE ESSENTIAL TO TAKE YOUR VEHICLE TO AN Official Aprilia Dealer OR SPECIALISED TYRE WORKSHOP TO CARRY OUT THE OPERATIONS ABOVE. NEW TYRES MAY BE COATED WITH A SLIPPERY COATING: RIDE WITH CAUTION DURING THE FIRST KILOMETRES. DO NOT APPLY UNSUITABLE LIQUIDS ON TYRES. WHEN TYRES ARE OLD, THE MATERIAL MAY HARDEN AND NOT PROVIDE ADEQUATE ROAD HOLDING, EVEN IF TYRES ARE STILL WITHIN THE WEAR LIMIT.**

**SHOULD THIS OCCUR, REPLACE THE TYRES.**

**Minimum tread depth:**

front and rear 2 mm (0.079 in) (USA 3 mm - 0.118 in) or more if so required by applicable legislation in the country where the vehicle is used.

## Spark plug dismantlement

### CAUTION

TO REMOVE, CHECK, CLEAN AND REPLACE SPARK PLUGS, PLEASE CONTACT AN Official Aprilia Dealer. IF YOU HAVE SUFFICIENT EXPERIENCE, FOLLOW THE INSTRUCTIONS IN THIS WORKSHOP BOOKLET, WHICH IS AVAILABLE AT ANY DEALER.

## Removing ducts (04\_06, 04\_07, 04\_08)

### NOTE

THE FOLLOWING OPERATIONS REFER TO ONE SIDE OF THE VEHICLE, BUT APPLY TO BOTH.

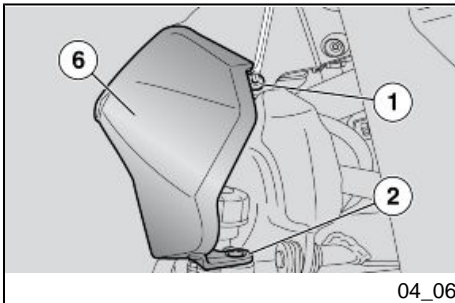

- Unscrew and remove the upper front fixing screw (1).
- Unscrew and remove the lower front fixing screw (2).

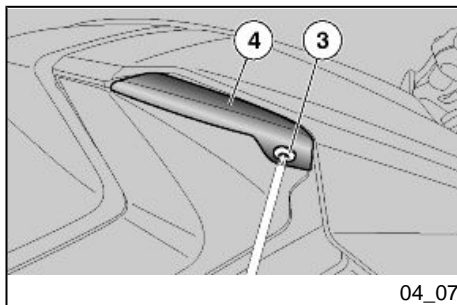

- Undo and remove the side bumper fixing screw (3).
- Remove the side bumper (4).
- Undo and remove the rear fixing screw (5) and remove the duct (6).

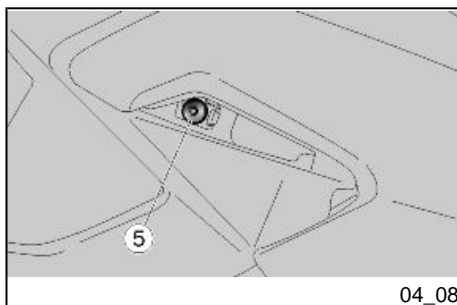

## Removing the air filter

### CAUTION

**TO REMOVE, CHECK AND REPLACE THE AIR FILTER, PLEASE CONTACT AN Official Aprilia Dealer. IF YOU ARE ADEQUATELY TRAINED AND EXPERIENCED, REFER TO THE INSTRUCTIONS IN THIS WORKSHOP BOOKLET AVAILABLE ALSO AT ANY DEALER.**

**Cooling fluid level (04\_09, 04\_10)**

**DO NOT USE YOUR MOTORCYCLE IF THE COOLANT LEVEL IS BELOW THE MINIMUM LEVEL MARKED «MIN».**

**CAUTION**

**COOLANT IS TOXIC IF INGESTED; CONTACT WITH YOUR EYES OR SKIN MAY CAUSE IRRITATION. IF THE FLUID GETS IN CONTACT WITH THE EYES OR SKIN, RINSE REPEATEDLY WITH PLENTY OF WATER AND SEEK MEDICAL ADVICE. IF SWALLOWED, INDUCE VOMITING, RINSE MOUTH AND THROAT WITH PLENTY OF WATER AND SEEK MEDICAL ADVICE IMMEDIATELY.**

**CAUTION**

**TAKE CARE NOT TO POUR COOLANT ONTO HOT ENGINE OR EXHAUST SYSTEM COMPONENTS; THE FLUID MAY CATCH FIRE AND BURN WITH INVISIBLE FLAMES. WHEN CARRYING OUT MAINTENANCE OPERATIONS, IT IS ADVISABLE TO WEAR LATEX GLOVES. CONTACT AN Official APRILIA Dealer FOR REPLACEMENT.**

**DO NOT DISPOSE OF THE FLUID INTO THE ENVIRONMENT.**

**KEEP OUT OF THE REACH OF CHILDREN**

**DO NOT REMOVE THE COVER OF THE EXPANSION TANK (1) WHEN THE ENGINE IS HOT AS THE COOLANT IS UNDER PRESSURE AND AT A HIGH TEMPERATURE. CONTACT WITH SKIN OR CLOTHES MAY CAUSE SERIOUS BURNS AND/OR INJURIES.**

**NOTE**

**TAKE YOUR VEHICLE TO AN Official APRILIA Dealer TO HAVE THE COOLANT CHANGED.**

**WARNING**

**WAIT FOR THE ENGINE TO COOL DOWN BEFORE CHECKING OR TOPPING-UP THE COOLANT LEVEL.**

**CHECK AND TOPPING-UP**

- Shut off the engine and wait until it cools off.
- Keep the vehicle upright and with the two wheels on the ground.
- Turn the handlebar to the left, keeping the vehicle upright.
- Make sure that the coolant level in the expansion tank is between the **"MAX"** (**"MAX"**= maximum level) and **"MIN"** (**"MIN"**= minimum level) reference marks

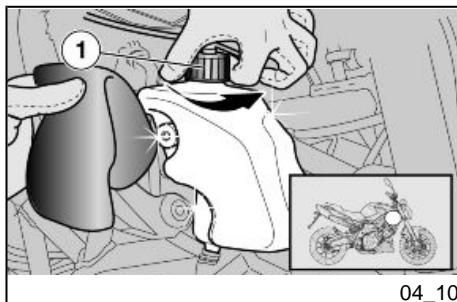
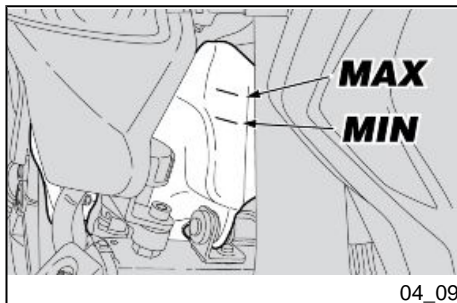
**Otherwise:**

- Remove the right duct.
- Remove the filler cap (1).
- Top up with the recommended coolant until the level is near the **"MAX"** reference mark. Do not exceed this level or the coolant will spill out when the engine is turning.
- Refit and lock the filler cap (1).

**CAUTION**

**IN THE EVENT OF COOLANT CONSUMPTION OR IF THE RESERVOIR IS EMPTY, CHECK FOR LEAKS IN THE CIRCUIT.**

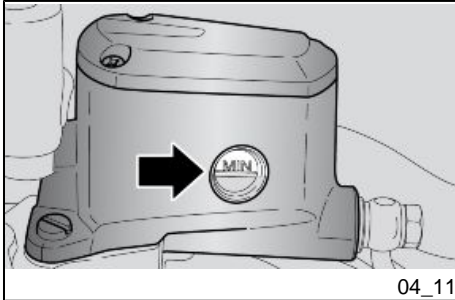

04\_11

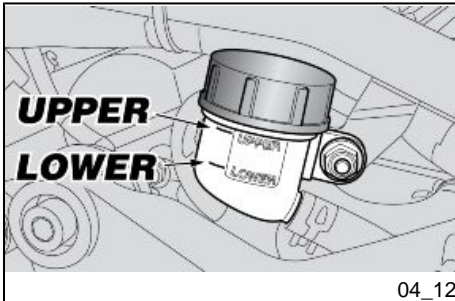

04\_12

**Checking the brake oil level (04\_11, 04\_12)**

- For the front brake, rest the vehicle on its stand and turn the handlebar so that the fluid in the reservoir is parallel to the reservoir edge.
- Check that the fluid in the reservoir is above the "**MIN**" reference mark.
- For the rear brake, keep the vehicle upright and check that the fluid in the reservoir is parallel to the reservoir edge.
- Make sure that the fluid level in the reservoir is above the "**LOWER**" reference mark.

Top-up if the fluid does not reach at least the "**LOWER**" / "**MIN**" reference mark.

- Check brake pads and disc for wear
- If the pads and/or the disc do not need replacing, top up the fluid.



## Braking system fluid top up

### CAUTION

**TO HAVE THE BRAKING SYSTEM FLUID TOPPED-UP, PLEASE CONTACT AN Official Aprilia Dealer. IF YOU ARE SUITABLY AND EXPERIENCED, FOLLOW THE INSTRUCTIONS IN THE WORKSHOP BOOKLET, WHICH IS AVAILABLE FROM ANY DEALER.**

## Checking clutch fluid (04\_13)

- Rest the vehicle on its stand.
- Turn the handlebar so that the fluid in the reservoir is parallel to the reservoir edge.
- Make sure that the fluid level in the reservoir is above the "MIN" reference mark:

Top-up if the fluid does not reach at least the "MIN" reference mark.

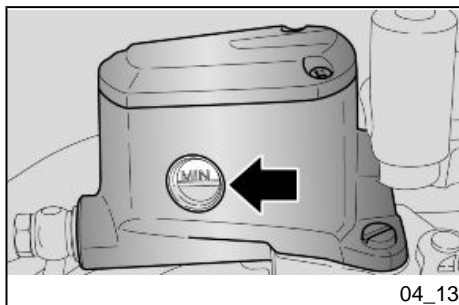

04\_13

## Topping up clutch fluid

### CAUTION

**FOR CLUTCH FLUID TOP-UP, PLEASE CONTACT AND Official Aprilia Dealer. IF YOU ARE ADEQUATELY TRAINED AND EXPERIENCED, REFER TO THE INSTRUCTIONS IN THIS WORKSHOP BOOKLET AVAILABLE ALSO AT ANY DEALER.**

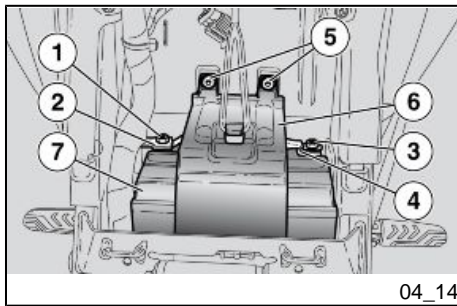

## Use of a new battery (04\_14)

- Make sure that the ignition switch is set to "OFF".
- Remove the rider saddle.
- Undo and remove the screw (1) of the negative terminal (-).
- Move the negative lead (2) aside.
- Undo and remove the screw (3) of the positive terminal (+).
- Move the positive lead (4) aside.
- Undo and remove the two screws (5).
- Remove the battery locking bracket (6).
- Hold the battery (7) firmly and lift it out of its compartment.
- Put the battery (7) away on a level surface in a cool and dry place.
- Refit the rider saddle.

### CAUTION

**WHEN REFITTING THE BATTERY, MAKE SURE IT IS CORRECTLY POSITIONED AND POLES ARE NOT INVERTED.**

### CAUTION

**UPON REFITTING, CONNECT THE LEAD TO THE POSITIVE TERMINAL (+) FIRST AND AFTERWARDS THE LEAD TO THE NEGATIVE TERMINAL (-).**



**CHECK THAT THE BATTERY LEADS AND TERMINALS ARE:**

- IN GOOD CONDITION (NOT CORRODED OR COVERED BY DEPOSITS);
- COVERED BY NEUTRAL GREASE OR PETROLEUM JELLY.

## Checking the electrolyte level

### WARNING

**THIS VEHICLE IS FITTED WITH A MAINTENANCE-FREE BATTERY AND DOES NOT NEED ANY INTERVENTION, EXCEPT FOR SPORADIC CHECKS AND RECHARGE.**

## Charging the battery

- Remove the battery.
- Get an adequate battery charger.
- Set the battery charger for the recharge type indicated.
- Connect the battery to the battery charger.

### CAUTION



**WHEN RECHARGING OR USING THE BATTERY, BE CAREFUL TO HAVE THE ROOM ADEQUATELY AIRED. DO NOT BREATHE GASES RELEASED WHEN THE BATTERY IS RECHARGING.**

Switch on the battery charger.

### Characteristic

#### RECHARGE MODES:

Recharge - Ordinary

Electric Current - 1.0 A

Time - 8-10 hours

Recharge - Fast

Electric Current - 10 A

Time - 0.5 hours

## Long periods of inactivity



**IF THE VEHICLE IS OUT OF USE FOR MORE THAN TWENTY DAYS, DISCONNECT THE 30 A FUSE TO PREVENT BATTERY DETERIORATION CAUSED BY CURRENT CONSUMPTION BY THE MULTIFUNCTION COMPUTER.**

### CAUTION

**REMOVING THE 30 A FUSES RESETS THESE FUNCTIONS: DIGITAL CLOCK, TRIP INFORMATION AND CHRONOMETER TIMES.**

If the vehicle is inactive longer than fifteen days, it is necessary to recharge the battery to avoid sulphation.

- Remove the battery.

In winter or when the vehicle is out of use for prolonged periods, check charge level frequently (about once a month) to prevent deterioration.

- Recharge it fully with an ordinary charge.

If the battery is still on the vehicle, disconnect the cables from the terminals.

### NOTE

**THE FIRST TIME THE ENGINE IS STARTED AFTER RECONNECTING THE BATTERY LEADS, WAIT 20 SECONDS BETWEEN THE MOMENT THE KEY IS SET TO "KEY ON" AND THE MOMENT THE STARTER BUTTON CAN BE PUSHED.**

**THE ENGINE WILL NOT START IF START-UP IS ATTEMPTED BEFORE THE PRE-SET 20 SECONDS ELAPSE.**

### **Fuses (04\_15, 04\_16, 04\_17, 04\_18, 04\_19)**

Check fuses in case of failure or irregular functioning of an electrical component or engine starting failure.

Check the auxiliary 15A fuses first, then the main 30A fuses.

#### **CAUTION**



**DO NOT REPAIR FAULTY FUSES.**

**NEVER USE A FUSE THAT IS DIFFERENT THAN WHAT IS SPECIFIED TO PREVENT DAMAGES TO THE ELECTRICAL SYSTEM OR SHORT CIRCUITS, AND THE RISK OF FIRE.**

#### **CAUTION**

**A FUSE THAT BLOWS FREQUENTLY MAY INDICATE A SHORT CIRCUIT OR OVERLOAD. IF THIS OCCURS, CONSULT AN APRILIA Official Dealer.**

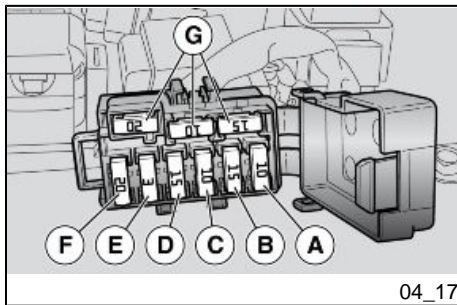
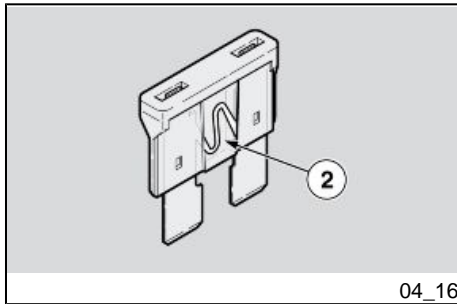
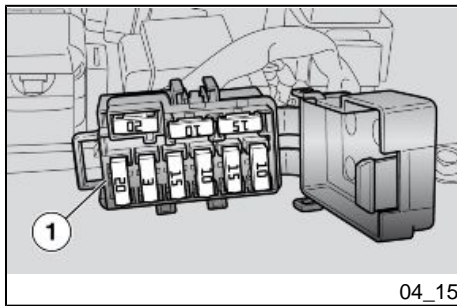

To check:

- Set the ignition switch to "OFF" to avoid an accidental short circuit.
- Remove the rider saddle.
- Open the cover of the auxiliary fuse box (1).
- Take out one fuse at a time and check whether the filament (2) is broken.
- Before replacing the fuse, find and solve, whenever possible, the problem that caused it to blow.
- If the fuse is damaged, replace it with one of the same current rating.
- To check the main fuses, carry out the same operations described above for auxiliary fuses.

#### NOTE

**IF THE SPARE FUSE IS USED, REPLACE WITH ONE OF THE SAME TYPE IN THE CORRESPONDING FITTING.**

#### CAUTION

**REMOVING THE 30 A FUSES RESETS THESE FUNCTIONS: DIGITAL CLOCK, TRIP INFORMATION AND CHRONOMETER TIMES.**

#### AUXILIARY FUSES

A - Recovery logic relay, Stop, Horn, daylight running lights, License plate light (10 A).

B - High-beam/low-beam lights, Light logic relay coil (15 A).

C - Live positive lead to the throttle control unit and to instrument panel, Instrument panel diagnosis (10 A).

D - Battery positive to instrument panel and to throttle control unit (15 A).

E - Battery positive, ECU control unit (3 A).

F - Oxygen sensor heater, Coils, Start-up logic, Fan and injection relay, Fuel pump, Purge valve, Injectors, ECU, Start-up logic (20A).

G - Spare fuses (10 - 15 - 20 A)

#### MAIN FUSES - version without ABS

H - Spare fuses (30 A)

I - Battery charging, fan relay, live positive (30 A)

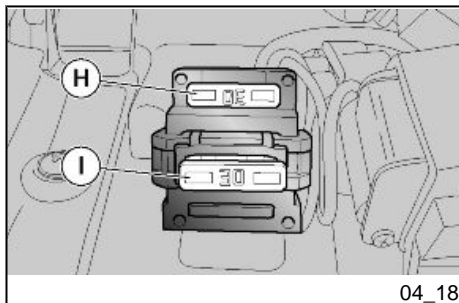

#### MAIN FUSES - version with ABS

H - ABS fuse (20 A)

I - Battery charging, fan relay, live positive (30 A)

J - Spare fuses (20 A - 30 A)

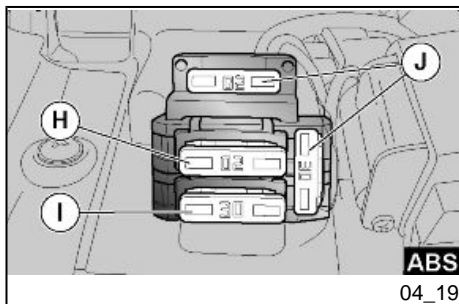

## Lamps (04\_20, 04\_21, 04\_22, 04\_23, 04\_24)

### CAUTION



**BEFORE REPLACING A BULB, TURN THE IGNITION SWITCH TO «KEY OFF» AND WAIT A FEW MINUTES FOR THE BULB TO COOL OFF.**

**WEAR CLEAN GLOVES OR USE A CLEAN DRY CLOTH TO REPLACE THE BULB.**

**DO NOT LEAVE PRINTS ON THE BULB AS THIS MAY CAUSE IT TO OVERHEAT OR EVEN BLOW OUT. IF YOU TOUCH THE BULB WITHOUT WEARING GLOVES, CLEAN OFF PRINTS WITH ALCOHOL TO AVOID DAMAGING THE BULB.**

**DO NOT FORCE ELECTRICAL CABLES.**

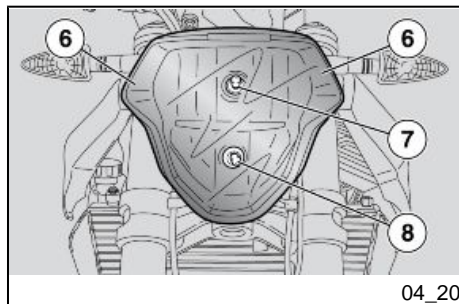

Remove the windshield in order to reach the bulbs of the headlamp, see (FAIRINGS).

### BULB LAYOUT

In the headlamp there are:

- low beam light bulb (8)
- high beam light bulb (7)
- tail light bulbs (6) (two)



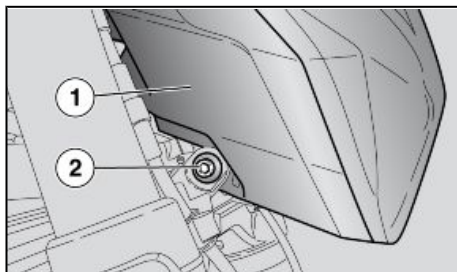

04\_21

### HEADLAMP BULB REPLACEMENT

- Rest the vehicle on its stand
- Loosen the fixing pin (2).
- Operating on both sides, undo and remove the fixing screw (3).
- Tilt the headlamp unit (1) forward keeping it connected to the pin.

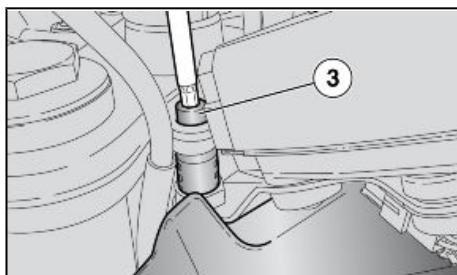

04\_22

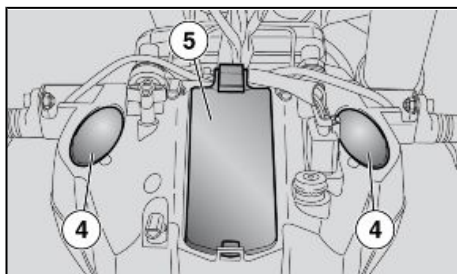

04\_23

### LOW BEAM LIGHT BULB

- Remove the cover (5).
- Hold the two bulb electric connectors, pull and disconnect them from the bulb.
- Release the two ends of the retaining spring located on the bulb holder.
- Pull the low beam light bulb (8) out of its fitting.

### HIGH BEAM BULB

- Remove the cover (5).
- Hold the two bulb electric connectors, pull and disconnect them from the bulb.
- Release the two ends of the retaining spring located on the bulb holder.
- Pull the high beam light bulb (7) out of its fitting.

Install a bulb of the same type adequately.

#### CAUTION

**INSERT THE BULB INTO THE BULB HOLDER, MAKING SURE THE REFERENCE FITTINGS MATCH.**

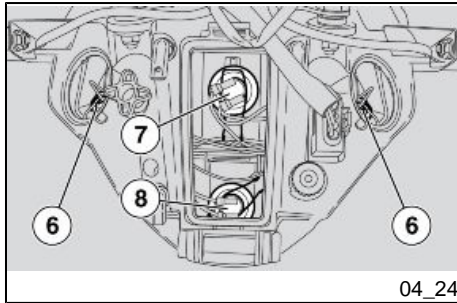

#### TAIL LIGHT BULBS

- Remove the plastic cover (4) with a screwdriver.
- Hold the tail light bulb holder, pull and take it out of its fitting.
- Remove the tail light bulb (6) and replace it with another of the same type.
- Check the proper insertion of the bulb in the bulb holder.

#### Headlight adjustment (04\_25, 04\_26, 04\_27)

#### NOTE

**IN COMPLIANCE WITH LOCAL LEGISLATION, SPECIFIC PROCEDURES MUST BE FOLLOWED WHEN ALIGNING THE LIGHTS.**

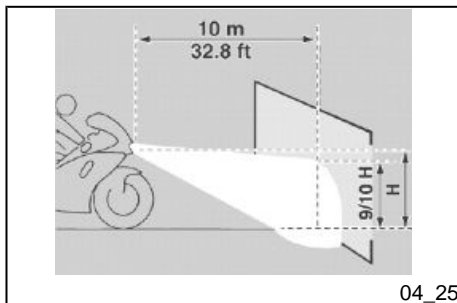

04\_25

EU: To quickly and easily check the alignment of the front light, place the vehicle on a level surface 10 m (32.8 ft) away from a vertical wall. Turn on the dipped beam light, sit on the vehicle and check that the light beam projected onto the wall is a little below the level of the headlight (about 9/10 of the total height).

#### In order to carry out vertical adjustment of the light beam:

- Rest the vehicle on its stand.
- Working from the left rear side of the windshield, use a short crosshead screwdriver on the specific screw (1). SCREW it (clockwise) to raise the light beams; UNDO the screw (anticlockwise) to lower the light beam.
- Repeat the same procedure for the right side headlight.

#### NOTE

**CHECK THAT THE LIGHT BEAM VERTICAL DIRECTION IS CORRECT.**

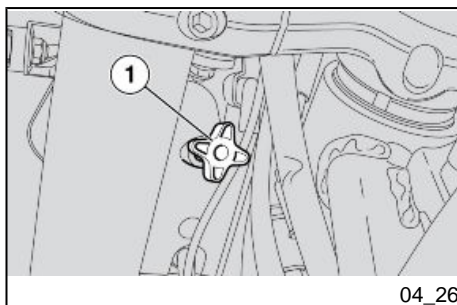

04\_26

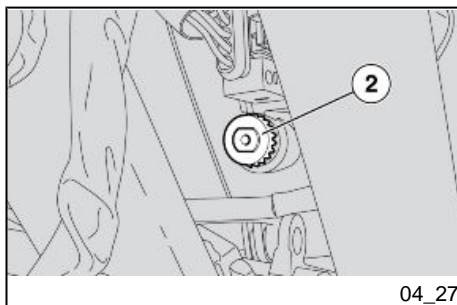

04\_27

#### In order to carry out horizontal adjustment of the light beam:

- Rest the vehicle on its stand.
- Working from the left rear side of the windshield, use a short crosshead screwdriver on the specific screw (2). SCREW it (clockwise) to move the light beam to the left; UNDO it (anticlockwise) to move the light beam to the right.
- Repeat the same procedure for the right side headlight.

#### NOTE

**CHECK THAT THE LIGHT BEAM HORIZONTAL DIRECTION IS CORRECT.**

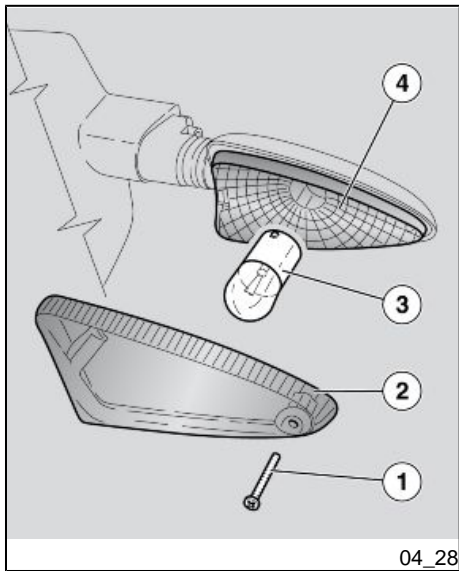

### Front direction indicators (04\_28)

- Rest the vehicle on its stand.
- Loosen and remove screw (1).
- Remove glass (2).
- Press bulb (3) slightly and turn it anticlockwise.
- Pull the bulb (3) out of its fitting.
- Insert a bulb of the same type adequately.

#### WARNING

**IF THE HEADLIGHT (4) PROTRUDES FROM ITS FITTING, INSERT IT AGAIN PROPERLY.**

### Rear optical unit

#### CAUTION

**TO REMOVE, CHECK AND REPLACE THE BULB, PLEASE CONTACT AN Official Aprilia Dealer. IF YOU ARE ADEQUATELY TRAINED AND EXPERIENCED, REFER TO THE INSTRUCTIONS IN THIS WORKSHOP BOOKLET AVAILABLE ALSO AT ANY DEALER.**

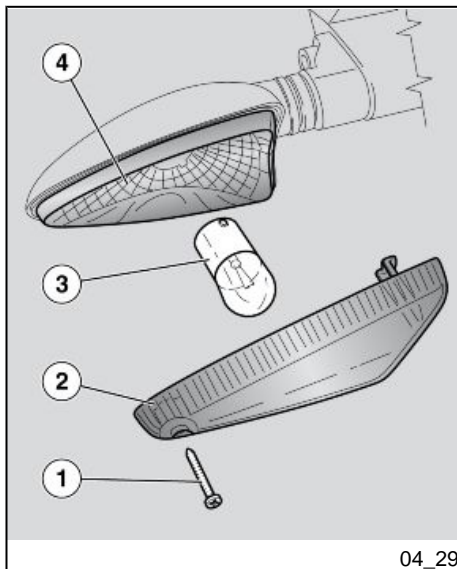

04\_29

### Rear turn indicators (04\_29)

- Rest the vehicle on its stand.
- Loosen and remove screw (1).
- Remove glass (2).
- Press bulb (3) slightly and turn it anticlockwise.
- Pull the bulb (3) out of its fitting.
- Insert a bulb of the same type adequately.

#### WARNING

**IF THE HEADLIGHT (4) PROTRUDES FROM ITS FITTING, INSERT IT AGAIN PROPERLY.**

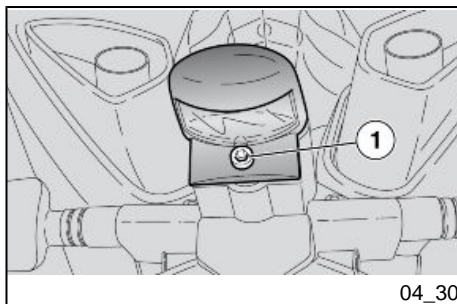

04\_30

### Number plate light (04\_30, 04\_31)

- Rest the vehicle on its stand.
- Unscrew and remove the fixing screw (1) and collect the nut.

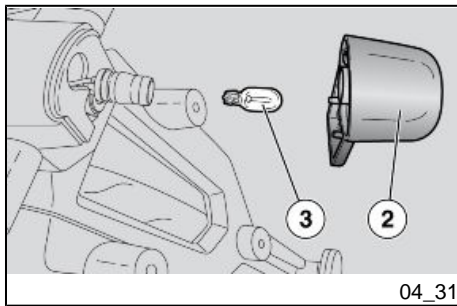

- Take out the glass of the license plate light (2).
- Remove the bulb (3) and replace it with another of the same type.

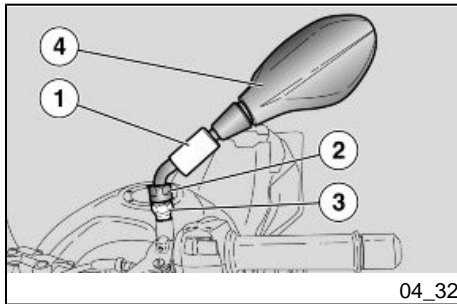

### Rear-view mirrors (04\_32, 04\_33)

- Park the vehicle on its centre stand on safe and level ground.
- Move the protection casing (1).



**HOLD THE REAR-VIEW MIRROR (4) TO AVOID DROPPING IT BY ACCIDENT.**

- Keep the screw (2) blocked and completely unscrew the nut (3).



**HANDLE PLASTIC AND PAINTED COMPONENTS WITH CARE, DO NOT SCRATCH OR SPOIL THEM.**

- Remove the rear-view mirror (4).

**CAUTION**

REPEAT THE PROCEDURE TO REMOVE THE OTHER MIRROR.



AFTER REFITTING, ADJUST THE REAR-VIEW MIRRORS CORRECTLY AND TIGHTEN THE NUTS IN ORDER TO ENSURE STABILITY.

After refitting:

- Adjust the rear-view mirror angle correctly.

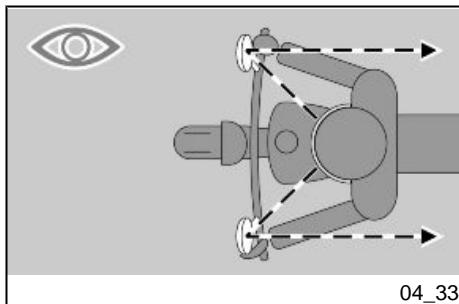

### Front and rear disc brake (04\_34, 04\_35, 04\_36)

**CAUTION**

CHECK THE BRAKE PAD WEAR BEFORE EACH TRIP AND EVERY 5000 km (3106 mi).

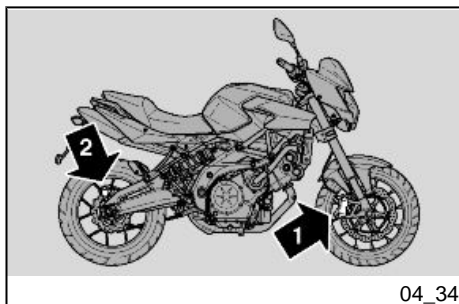

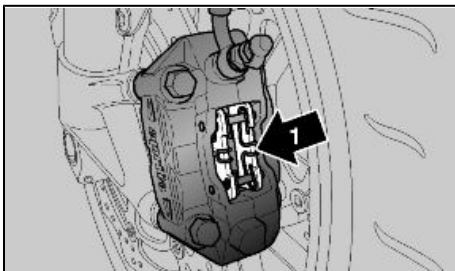

04\_35

### To perform a quick pad wear check:

- Rest the vehicle on its stand.
- Carry out a visual inspection of brake disc and pads as follows:

- look from the back, for the front brake callipers (1);

- on the right side of the vehicle, look from above downwards, for the rear brake calliper (2).

### CAUTION

**EXCESSIVE WEAR OF THE FRICTION MATERIAL MAKES THE PAD METAL SUPPORT GET INTO CONTACT WITH THE DISC, WHICH RESULTS IN A METALLIC NOISE AND SPARKS IN THE CALLIPER; THEREFORE, BRAKING EFFICIENCY AND DISC SAFETY AND INTEGRITY ARE AT RISK.**

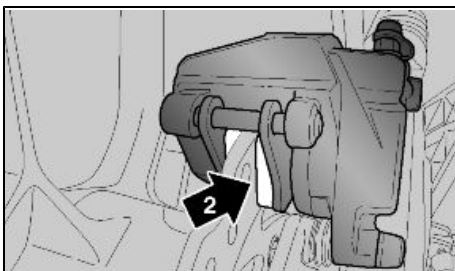

04\_36

If the friction material thickness (even of one front or rear pad) is reduced to a value of about **1.5 mm (0.06 in)** (or even if one of the wear indicators is not very visible), contact an Official **Aprilia** Dealer to have all the calliper pads replaced.

### Periods of inactivity (04\_37)

Take some measures to avoid the side effects of not using the scooter. Besides, it is necessary to carry out general repairs and checks before garaging the motorcycle as one can forget to do so afterwards.



Proceed as follows:

- Remove the battery.
- Wash and dry the vehicle.
- Polish the painted surfaces.
- Inflate the tyres.
- Set the vehicle in a room with no heating or humidity, with minimum temperature variations and not exposed to sun rays.
- Wrap and tie a plastic bag around the exhaust pipe opening to keep moisture out.

#### **NOTE**

**PLACE A SUITABLE SUPPORT UNDER THE VEHICLE TO KEEP BOTH WHEELS OFF THE GROUND.**

- Put the vehicle on the front stand (optional) and on the back stand (optional).
- Cover the vehicle (do not use plastic or waterproof materials).

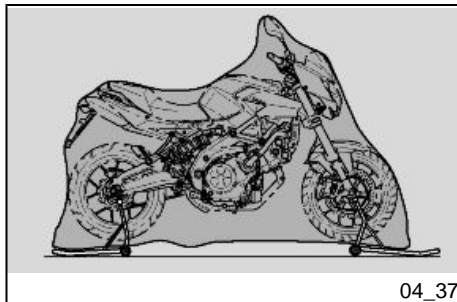

#### **AFTER STORAGE**

#### **NOTE**

**TAKE THE PLASTIC BAGS OFF THE EXHAUST PIPE OPENING.**

- Uncover and clean the vehicle.
- Check the battery for correct charge and install it.
- Refill the fuel tank.

- Carry out the pre-ride checks.

**CAUTION**

**AS A TEST, RIDE THE MOTORCYCLE FOR A FEW KILOMETRES AT A MODERATE SPEED AND AWAY FROM TRAFFIC AREAS.**

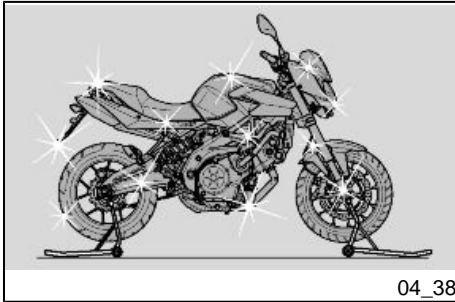
**Cleaning the vehicle (04\_38, 04\_39, 04\_40)**

**Clean the motorcycle frequently if exposed to adverse conditions, such as:**

- Air pollution (cities and industrial areas).
- Salinity and humidity in the atmosphere (seashore areas, hot and wet weather).
- Special environmental/seasonal conditions (use of salt, anti-icing chemical products on the roads in winter).
- Always clean off any smog and pollution residue, tar stains, insects, bird droppings, etc. from the bodywork.
- Avoid parking the vehicle under trees. During some seasons, resins, fruits or leaves containing aggressive chemical substances that may damage the paintwork may fall from trees.
- Clean the instrument panel with a soft, damp cloth.

**CAUTION**

**BEFORE WASHING THE VEHICLE, COVER THE ENGINE AIR INTAKES AND THE EXHAUST PIPES.**

**CAUTION**

**AFTER CLEANING YOUR MOTORCYCLE, BRAKING EFFICIENCY MAY BE TEMPORARILY AFFECTED DUE TO THE PRESENCE OF WATER ON THE FRICTION SURFACES OF THE BRAKING CIRCUIT. ALLOW LONGER BRAKING DISTANCES TO PREVENT ACCIDENTS. BRAKE REPEATEDLY TO RESTORE NORMAL OPERATION. CARRY OUT THE PRE-RIDE CHECKS.**

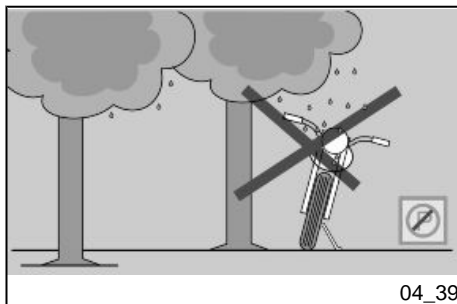

04\_39

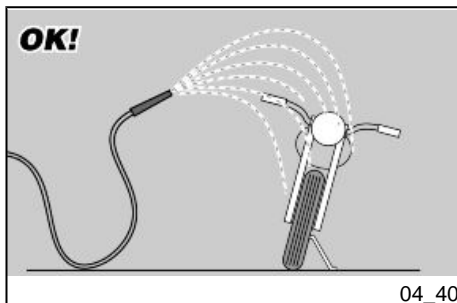

04\_40

To remove dirt and mud accumulated on painted surfaces, wet the soiled areas thoroughly with a low-pressure water jet, then remove dirt and mud with a soft car body sponge soaked abundantly in a solution of car body shampoo in water (2 - 4% shampoo dissolved in water). Then rinse with plenty of water, and dry with a chamois leather. To clean the engine outer parts, use degreasing detergent, brushes and old cloths. Wash anodised or painted aluminium parts with neutral soap and water. Using aggressive detergents may damage the surface treatment of these components.



**TO CLEAN THE HEADLIGHTS USE A SPONGE SOAKED IN WATER AND MILD DETERGENT, RUBBING THE SURFACE GENTLY AND RINSING FREQUENTLY WITH PLENTY OF WATER. REMEMBER TO CLEAN THE VEHICLE CAREFULLY BEFORE APPLYING SILICON WAX POLISH. DO NOT POLISH MATT-PAINTED SURFACES WITH POLISHING PASTE. THE VEHICLE SHOULD NEVER BE WASHED IN DIRECT SUNLIGHT, ESPECIALLY DURING SUMMER, OR WITH THE BODYWORK STILL HOT AS THE CAR SHAMPOO CAN DAMAGE THE PAINTWORK IF IT DRIES BEFORE BEING RINSED OFF.**

**CAUTION**

**NEVER USE CLOTHS SOAKED IN PETROL, DIESEL OIL OR KEROSENE FOR CLEANING THE PAINTED OR PLASTIC SURFACES SO AS NOT TO DAMAGE THE LUSTRE FINISH OR ALTER THE MECHANICAL PROPERTIES.**

**CAUTION**

**DO NOT USE WATER (OR LIQUIDS) AT TEMPERATURES OVER 40°C (104°F) WHEN CLEANING THE VEHICLE PLASTIC PARTS. DO NOT AIM HIGH PRESSURE AIR/WATER JETS OR STEAM JETS DIRECTLY ON THESE COMPONENTS. DO NOT USE ALCOHOL OR SOLVENTS TO CLEAN ANY RUBBER OR PLASTIC SADDLE COMPONENTS: USE WATER AND MILD SOAP.**

**CAUTION**

**DO NOT USE SOLVENTS OR PETROL BY-PRODUCTS (ACETONE, TRICHLOROETHYLENE, TURPENTINE, PETROL, THINNERS) TO CLEAN THE SADDLE. USE INSTEAD DETERGENTS WITH SURFACE ACTIVE AGENTS NOT EXCEEDING 5% (NEUTRAL SOAP, DEGREASING DETERGENTS OR ALCOHOL).**

**DRY THE SADDLE WELL AFTER CLEANING.**

**CAUTION**

**DO NOT APPLY PROTECTIVE WAX ON THE SADDLE AS IT MAY BECOME SLIPPERY.**

## Transport (04\_41)

### NOTE



BEFORE TRANSPORTING THE VEHICLE, IT IS NECESSARY TO EMPTY THE FUEL TANK AND THE CARBURETTOR ADEQUATELY, CHECKING THAT THEY ARE DRY.

DURING TRANSPORT, THE VEHICLE SHOULD BE UPRIGHT AND SECURELY ANCHORED AND SHOULD HAVE THE FIRST GEAR ENGAGED SO AS TO AVOID POSSIBLE FUEL, OIL OR COOLANT LEAKS.

IN CASE OF FAILURE, DO NOT TOW THE VEHICLE BUT CONTACT A ROAD ASSISTANCE SERVICE INSTEAD TO HAVE THE INFLAMMABLE FLUIDS DRAINED .

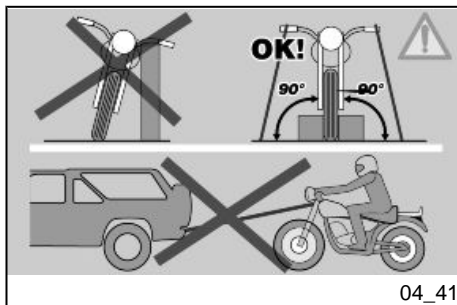

04\_41

## Chain backlash check (04\_42)

### To check the clearance:

- Shut off the engine.
- Rest the vehicle on its stand.
- Engage neutral gear.
- Check that vertical oscillation at a point between the pinion and the crown on the lower branch of the chain is around **25 mm (0.98 in)**.
- Move the vehicle forward so as to check the chain vertical oscillation in other positions too. clearance should remain constant at all wheel rotation phases.

Adjust backlash if it is uniform but higher or lower than **25 mm (0.98 in)**.

### CAUTION

IF CLEARANCE IS GREATER AT SOME POSITIONS, THIS MEANS THAT SOME CHAIN LINKS ARE FLATTENED OR JAMMED.

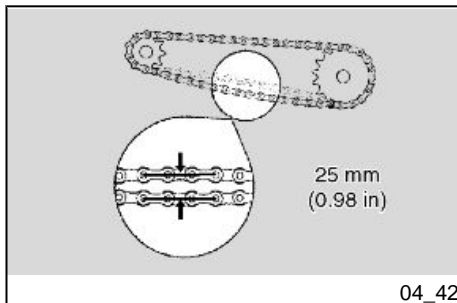

04\_42

TO AVOID RISK OF SEIZURE, LUBRICATE THE CHAIN ON A REGULAR BASIS.

## Chain backlash adjustment

### CAUTION

TO ADJUST THE CHAIN BACKLASH, PLEASE CONTACT AN Official Aprilia Dealer. IF YOU ARE ADEQUATELY TRAINED AND EXPERIENCED, REFER TO THE INSTRUCTIONS IN THIS WORKSHOP BOOKLET AVAILABLE ALSO AT ANY DEALER.

## Checking wear of chain, front and rear sprockets

Also check the following parts and make sure that the chain, pinion and sprocket do not have:

- Damaged rollers.
- Loosened pins.
- Dry, rusty, flattened or jammed chain links.
- Excessive wear.
- Missing sealing rings.
- Excessively worn or damaged pinion or sprocket teeth.

### CAUTION

IF THE CHAIN ROLLERS ARE DAMAGED, THE PINS ARE LOOSENED AND/OR THE SEAL RINGS ARE MISSING OR DAMAGED, THE WHOLE CHAIN APPARATUS (PINION, SPROCKET AND CHAIN) SHOULD BE REPLACED.

### CAUTION

LUBRICATE THE CHAIN ON A REGULAR BASIS, PARTICULARLY IF YOU FIND DRY OR RUSTY PARTS. FLATTENED OR JAMMED CHAIN LINKS SHOULD BE

**LUBRICATED AND GOOD OPERATING CONDITIONS RESTORED. IF REPAIR IS NOT POSSIBLE, CONTACT AN Official Aprilia Dealer TO HAVE IT REPLACED.**

### **Chain lubrication and cleaning**

Never wash the chain with high pressure air/water jets or steam jets or highly flammable solvents.

- Wash the chain with fuel oil or kerosene. Maintenance operations should be more frequent if there are signs of quick rust.

Lubricate the chain whenever necessary.

- After washing and drying the chain, lubricate it with spray grease for sealed chains.



**THE TRANSMISSION CHAIN HAS RUBBER O-RINGS BETWEEN THE SIDE PLATES OF THE CHAIN ITSELF THAT ARE USED TO HOLD THE GREASE. UT-MOST ATTENTION IS REQUIRED WHEN ADJUSTING, LUBRICATING, WASHING OR REPLACING THE CHAIN.**

**CHAIN LUBRICANTS AVAILABLE ON THE MARKET CAN CONTAIN SUBSTANCES THAT DAMAGE THE CHAIN'S RUBBER O-RINGS.**

**NEVER USE THE VEHICLE JUST AFTER LUBRICATING THE CHAIN, AS THE LUBRICANT WOULD BE SPRAYED OUTWARD AND SPREAD OUT IN THE SURROUNDING AREA.**





# SHIVER 750 - SHIVER 750 ABS



**Chap. 05**  
**Technical data**

### **DIMENSIONS**

Max. length	2100 mm (82.68 in)
Max. width	800 mm (31.50 in)
Max. height (to windshield)	1135 mm (44.69 in)
Saddle height	810 mm (31.89 in)
Wheelbase	1440 mm (56.69 in)
Kerb weight	210 kg (463 lb)

### **ENGINE**

Model	M551M
Type	90° longitudinal V-twin, 4-stroke, 4 valves per cylinder, 2 overhead camshafts.
No. of cylinders	2
Total engine capacity	749.9 cm <sup>3</sup> (45.76 cu.in)
Bore / stroke	92 x 56.4 mm (3.62 x 2.22 cu.in)

Intake valve clearance	0.11 - 0.18 mm (0.0043 - 0.0071 in)
Exhaust valve clearance	0.16 - 0.23 mm (0.0063 - 0.0091 in)
Compression ratio	11.0: 1
Electric	Electric starter
Engine idle speed	1400 ± 100 rpm
Clutch	Multiple-disk, oil-bathed clutch with control on the left side of the handlebar
Lubrication system	Wet crankcase. Pressure system regulated by a trochoidal pump
Air filter	With dry cartridge filter
Cooling	Fluid

### **GEARBOX**

Type	Mechanical, 6 speeds with foot lever on the left hand side of the engine
------	--

### **CAPACITY**

Fuel (reserve included)	15 l (3.30 UKgal; 3.96 USgal)
Fuel reserve	3 l (0.66 UKgal; 0.79 USgal)
Engine oil	3.0 l (without oil filter change) (0.66 UKgal; 0.79 USgal) 3.2 l (with oil filter change) (0.70 UKgal; 0.85 USgal)
Coolant	1.8 l (0.40 UKgal; 0.48 USgal)
Seats	2
Vehicle max. load	190 kg (418.9 lb) (Rider + passenger + luggage)

### **GEAR RATIOS**

Gear ratio	Gear primary drive 38/71
1st gear ratio	14/36 (secondary)
2nd gear ratio	17/32 (secondary)
3rd gear ratio	20/30 (secondary)
4th gear ratio	22/28 (secondary)
5th gear ratio	23/26 (secondary)

6th gear ratio	24/25 (secondary)
Final drive gear ratio	16/44

### **DRIVE CHAIN**

Type	Endless (without master link) and with sealed links. No. of links 108
Model	525 ZRPK

### **FUEL SYSTEM**

Type	Electronic injection (Multipoint)
Throttle valve diameter	Ø 52 mm (2.05 in)
Fuel	Premium unleaded petrol, minimum octane rating 95 (NORM) and 85 (NOMM)

### **CHASSIS**

Type	Die-cast aluminium plates and high-strength steel tubular chassis.
------	--

Steering inclination angle (with extended suspension)	25.9°
Trail	109.6 mm (4.29 in)

### **SUSPENSION**

Front	Upside-down hydraulic action telescopic fork, Ø 43 mm (1.69 in) stems
Travel	120 mm (4.72 in)
Rear	Oscillating swingarm and adjustable hydraulic single shock absorber
Wheel travel	122 mm (4.80 in)

### **BRAKES**

Front	Double floating disc, Ø 320 mm (12.60 in), radially-mounted callipers with four plungers- two of them Ø 27 mm (1.06 in), 2 diam. 32.03 mm (1.26 in) and 4 pads
Rear	240 mm diam. (9.45 in) disc brake with a single 35 mm (1.38in) diam. piston calliper

**WHEEL RIMS**

Type	Light alloy rims with extractable bolt
Front	3.50 x 17"
Rear	5.50 x 17" or 6.00 x 17"

**TYRES**

Tyre type (standard)	DUNLOP SPORTMAX QUALIFIER - METZELER M3
Front	120/70 ZR17" (58W)
Inflation pressure	1 passenger: 2.3 bar (230 kPa) (33.36 PSI)  2 passengers: 2.5 bar (250 kPa) (36.26 PSI)
Rear (with wheel rim 5.50 x 17")	180/55 ZR17" (73W)
Rear (with wheel rim 6.00 x 17")	180/55 ZR17" (73W) or 190/50 ZR17" (73W)
Inflation pressure	1 passenger: 2.5 bar (250 kPa) (36.26 PSI)  2 passengers: 2.8 bar (280 kPa) (40.61 PSI)

### **SPARK PLUGS**

Standard spark plugs	NGK CR7EKB
Spark plug electrode gap	0.6 - 0.7 mm (0.024 - 0.028 in)
Resistance	5 kOhm

### **ELECTRICAL SYSTEM**

Battery	12 V - 10 Ah or 12 V - 12 Ah
Main fuses	30A - 40A
Secondary fuses	3A, 10A, 15A, 20A
ABS fuses (where foreseen)	20 A
Alternator (permanent magnet type)	13.5 V - 450 W at 6000 rpm
Electric	Electric starter
Ignition	Electronic, inductive, high-efficiency, integrated with the injection system, with variable advance separate HV coil.
Ignition advance	Three-dimensional map managed by control unit



**BULBS**

Low beam light	12 V - 55 W H7
High beam light	12 V - 55 W H7
Front daylight running light	12V - 5W x 2
Turn indicator light	12V - 10W
License plate light	12V - 5W
Rear daylight running light /stop light	12V - 5/21W x 2
Rpm indicator lighting	LED
Multifunction display lighting	LED

**WARNING LIGHTS**

High beam light	LED
Right turn indicator	LED
Left turn indicator	LED
General warning	LED
Gear in neutral	LED
Side stand down	LED
Fuel reserve	LED
ABS	LED

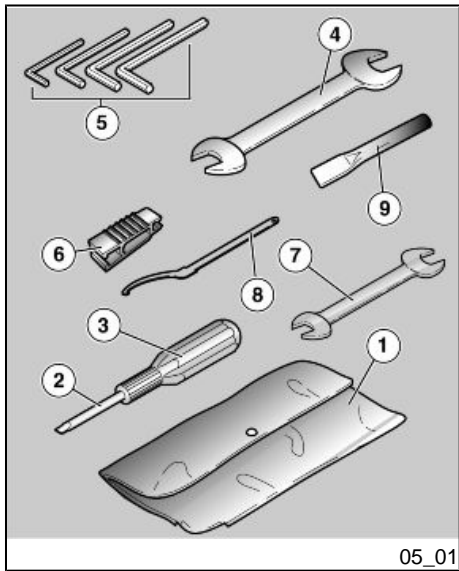

## Kit equipment (05\_01)

The tools supplied are:

- Toolkit pouch (1);
- Reversible screwdriver (2);
- Handle for reversible screwdriver (3);
- 11-13 mm (0.43 - 0.51 in) single open ended spanner (4);
- 3, 4, 5, 6 mm (0.12, 0.16, 0.20, 0.24 in) L-shaped hex Allen keys (5);
- Small pliers to extract fuses (6);
- 8-10 mm (0.31 - 0.39 in) double open ended spanner (7);
- Shock absorber ring nut preloading adjustment wrench (8)
- Flattened cylindrical wrench adaptor (9).

**Maximum weight allowed: 1.5 kg (3.30 lb)**

# SHIVER 750 - SHIVER 750 ABS

**aprilia**



**Chap. 06  
Programmed  
maintenance**

## Scheduled maintenance table

Correct maintenance is fundamental for ensuring the longevity of your vehicle and maintaining optimum function and performance.

To this end, Aprilia offers a set of checks and maintenance services (at the owner's expense), that are summarised in the table shown on the following page. Any minor faults must be reported without delay to an **Authorised Aprilia Dealer or Sub-Dealer** without waiting until the next scheduled service to solve it.

All scheduled services must be carried out at the specified intervals and mileage, as soon as the predetermined mileage is reached. Carrying out scheduled services on time is essential for the validity of your warranty. For further information regarding Warranty procedures and "Scheduled Maintenance", please refer to the "Warranty Booklet".

### NOTE

**CARRY OUT MAINTENANCE OPERATIONS AT HALF THE INTERVALS SPECIFIED IF THE VEHICLE IS USED IN PARTICULAR RAINY OR DUSTY CONDITIONS, OFF ROAD OR FOR TRACK USE.**

I: INSPECT AND CLEAN, ADJUST, LUBRICATE OR REPLACE IF NECESSARY

C: CLEAN, R: REPLACE, A: ADJUST, L: LUBRICATE

- (1) Check and clean and adjust or replace, if necessary, every 1000 Km (621 mi)
- (2) Replace every 2 years
- (3) Replace every 4 years
- (4) At each engine start
- (5) Check every month
- (6) Check each time the rear tyre is replaced
- (7) Replace at whichever of the following occurs first: 40000 km (24854 mi) or 4 years

**ROUTINE MAINTENANCE TABLE**

<b>km x 1,000</b>	<b>1</b>	<b>10</b>	<b>20</b>	<b>30</b>	<b>40</b>
Rear shock absorber			I		I
Spark plug			R		R
Drive chain (1)	I		I		I
Transmission cables and controls	I		I		I
Steering bearings and steering clearance	I		I		I
Wheel bearings			I		I
Diagnosis by tool	I	I	I	I	I
Brake discs	I		I		I
Air filter		I	R	I	R
Engine oil filter	R		R		R
Fork			I		I
General vehicle operation	I		I		I
Valve clearance			A		A
Cooling system			I		I
Braking systems	I		I		I
Light circuit	I		I		I
Safety switches			I		I
Clutch control fluid (2)	I		I		I
Brake fluid (2)	I		I		I
Coolant (2)	I		I		I

km x 1,000	1	10	20	30	40
Fork oil (7)					R
Engine oil	R		R		R
Light aiming			I		I
Fork oil seals			I		I
Flexible coupling (6)			I		I
Tyres - pressure/wear (5)	I	I	I	I	I
Wheels	I		I		I
Bolts and nuts tightening	I		I		I
Suspension and setting	I		I		I
Fault warning light on instrument panel (4)					
Fuel lines (3)			I		I
Clutch wear			I		I
Break pad wear	I	I	I	I	I



06\_01

### Table of recommended products (06\_01)

Piaggio & C. S.p.A. prescribes **eni** products for the scheduled maintenance of its vehicles

**RECOMMENDED PRODUCTS TABLE**

<b>Product</b>	<b>Description</b>	<b>Specifications</b>
ENI i-RIDE PG 15W-50	Engine oil	Use branded oils with performance equivalent to or exceeding API SJ, JASO MA - ACEA A3 - JASO MA2 specifications.
AGIP ARNICA SA 32	Fork oil (Marzocchi)	SAE 0W - ISO-L-HV
AGIP FORK 5W	Fork oil (Showa)	SAE 5W
FUCHS TITAN SAF 1091	Fork oil (Sachs)	-
AGIP MP GREASE	Black smooth textured lithium-calcium soap based grease containing EP (extreme pressure) additives with optimal water-repellent properties	ISO L-X-BCHB 2 - DIN 51 825 KP2K-20
AGIP CHAIN LUBE SPRAY	Spray lubricating grease	-
AGIP BRAKE 4	Brake fluid	SAE J 1703 - FMVSS 116 - DOT 3/4 - ISO 4925 - CUNA NC 956 DOT 4 synthetic fluid
AGIP BRAKE 5.1	Clutch fluid	FMVSS 116 - DOT 5.1 Non-silicone synthetic fluid
AGIP PERMANENT SPECIAL	Ethylene glycol-based antifreeze fluid with organic inhibition additives. Red, ready for use	ASTM D 3306 - ASTM D 4656 - ASTM D 4985 - CUNA NC 956-16





# TABLE OF CONTENTS

## **A**

ABS: 46  
Advanced functions: 36  
Air filter: 93  
Alarms: 30

## **B**

Battery: 15, 98, 99  
Brake: 15, 64, 96, 111  
Brake pedal: 64

## **C**

Chain: 117–119  
Clutch: 15, 65, 97  
Clutch fluid: 15, 97  
Clutch lever: 65  
coolant: 13  
Coolant: 13

## **D**

Disc brake: 111  
Display: 27

## **E**

Engine oil: 14, 86–89  
Engine stop: 46

## **F**

Fairings: 50  
Fork: 63  
Fuel: 12  
Fuses: 101

## **G**

Gearbox oil: 14

## **H**

Headlight: 106

Horn: 44

## **I**

Identification: 53  
Immobilizer: 49  
Instrument panel: 25

## **M**

Maintenance: 85, 131, 132  
Maintenance Table: 132  
Mirrors: 110

## **O**

Oil filter: 89

## **R**

rear-view mirrors: 110  
Recommended products:  
134

Ride by wire: 69

## **S**

Saddle: 51  
Scheduled maintenance:  
132  
Shock absorbers: 61  
Spark plug: 92  
Stand: 16, 77  
Start-up: 45  
Stop switch: 46

## **T**

Technical data: 121  
Turn indicators: 109  
Tyres: 90

## **W**

Warning lights: 13



#### THE VALUE OF SERVICE

As a result of continuous updates and specific technical training programmes for Aprilia products, only **Aprilia** Official Network mechanics know this vehicle fully and have the specific tools necessary to carry out maintenance and repair operations correctly.

The reliability of the vehicle also depends on its mechanical conditions. Checking the vehicle before riding it, its regular maintenance and the use of **original Aprilia spare parts** only are essential factors!

For information on the nearest **Official Dealer and/or Service Centre** consult our website:

[www.aprilia.com](http://www.aprilia.com)

Only by requesting aprilia original spare parts can you be sure of purchasing products that were developed and tested during the actual vehicle design stage. All aprilia original spare parts undergo quality control procedures to guarantee reliability and durability.

The descriptions and images in this publication are given for illustrative purposes only and are not binding.

Piaggio & C. While the basic characteristics as described and illustrated in this booklet remain unchanged, Piaggio & C. S.p.A. reserves the right, at any time and without being required to update this publication beforehand, to make any changes to components, parts or accessories, which it considers necessary to improve the product or which are required for manufacturing or construction reasons.

Not all versions/models shown in this publication are available in all Countries. The availability of individual versions/models should be confirmed with the official Aprilia sales network.

The Aprilia trademark is the property of Piaggio & C. S.p.A.

© Copyright 2015 - Piaggio & C. S.p.A. All rights reserved. Reproduction of this publication in whole or in part is prohibited.

Piaggio & C. S.p.A. Viale Rinaldo Piaggio, 25 - 56025 PONTEDERA (PI), Italy

[www.piaggio.com](http://www.piaggio.com)