

APRILIA WOULD LIKE TO THANK YOU

for having chosen one of its products. We have compiled this booklet to provide a comprehensive overview of your vehicle's quality features. Please read it carefully before riding the vehicle for the first time. It contains information, tips and precautions for using your vehicle. It also describes features, details and devices to assure you that you have made the right choice. We believe that if you follow our suggestions, you will soon find yourself in harmony with your new vehicle, and ride it fully satisfied for a long time. This booklet forms an integral part of the vehicle; should the vehicle be sold, it must be transferred to the new owner.

RSV4 1100



The instructions given in this manual are intended to provide a clear, simple guide to using your vehicle; it also describes routine maintenance procedures and regular checks that should be carried out on the vehicle at an **Aprilia Dealer or Authorised Workshop**. The booklet also contains instructions for simple repairs. Any operations not specifically described in this booklet require the use of special tools and/or particular technical knowledge: for these operations, please take your vehicle to an **Aprilia Dealer or Authorised Workshop**.



Personal safety

Failure to completely observe these instructions will result in serious risk of personal injury.



Safeguarding the environment

Sections marked with this symbol indicate the correct use of the vehicle to prevent damaging the environment.



Vehicle intactness

The incomplete or non-observance of these regulations leads to the risk of serious damage to the vehicle and sometimes even the invalidity of the guarantee

*The symbols illustrated above are very important. They are used to highlight parts of the booklet that should be read with particular care. The different symbols are used to make each topic in the manual simple and quick to locate. Before starting the engine, read this booklet carefully, particularly the "SAFE RIDING" section. Your safety as well as other's does not only depend on the quickness of your reflexes and agility, but also on how well you know your vehicle, the state of maintenance of the vehicle itself and your knowledge of the rules for SAFE RIDING. For your safety, get to know your vehicle well so as to safely ride and master it given any riding condition. **IMPORTANT** This booklet is an integral part of the vehicle, and must be handed over to the new owner in the event of sale.*

INDEX

GENERAL RULES.....	7	Button PIT.....	88
Foreword.....	8	System a-PRC (Aprilia Performance Ride Control).....	89
Motorcycle care.....	8	Immobilizer system operation.....	109
Carbon monoxide.....	11	The saddle.....	110
Fuel.....	12	Identification.....	113
Hot components.....	12	USE.....	115
Coolant.....	13	Checks.....	116
Used engine oil and gearbox oil.....	13	Refuelling.....	119
Brake fluid.....	14	Rear shock absorbers adjustment.....	121
Battery hydrogen gas and electrolyte.....	14	Rear shock absorbers setting.....	125
Stand.....	15	Front fork adjustment.....	127
Reporting of defects that affect safety.....	15	Front fork setting.....	130
VEHICLE.....	17	Steering shock absorber adjustment.....	133
Arrangement of the main components.....	18	Justering af greb til forbremse.....	135
Dashboard.....	21	Clutch lever adjustment.....	135
Digital instrument panel.....	23	Running in.....	136
Light unit.....	24	Starting up the engine.....	137
Digital lcd display.....	25	Moving off / riding.....	139
Alarms.....	32	Stopping the engine.....	144
Mapping selection.....	37	Parking.....	145
Control buttons.....	40	Catalytic silencer.....	146
Advanced functions.....	55	Stand.....	147
Ignition switch.....	78	Suggestion to prevent theft.....	148
Locking the steering wheel.....	79	Safe driving.....	148
a-PRC setting buttons.....	79	Basic safety rules.....	150
Horn button.....	80	MAINTENANCE.....	155
Switch direction indicators.....	81	Foreword.....	156
High/low beam selector.....	82	Engine oil level check.....	156
Passing button.....	82	Engine oil top-up.....	157
Daytime/night lights switch.....	83	Engine oil change.....	158
Start-up button.....	84	Engine oil filter replacement.....	158
Engine stop switch.....	84	Tyres.....	158
Selector Cruise Control / AWC.....	85	Spark plug dismantlement.....	160

Removing the air filter.....	160
Cooling fluid level.....	160
Coolant check.....	162
Coolant top-up.....	162
Checking the brake oil level.....	162
Braking system fluid top up.....	163
Battery.....	165
Battery removal.....	166
Use of a new battery.....	167
Charging the battery.....	168
Long periods of inactivity.....	170
Fuses.....	171
Lamps.....	176
Front light group.....	176
Headlight adjustment.....	177
Rear optical unit.....	179
Rear turn indicators.....	179
Number plate light.....	179
Rear-view mirrors.....	180
Front and rear disc brake.....	181
Periods of inactivity.....	182
Cleaning the vehicle.....	183
Transport.....	187
Transmission chain.....	187
Chain backlash check.....	189
Chain backlash adjustment.....	189
Checking wear of chain, front and rear sprockets.....	189
Chain lubrication and cleaning.....	190
TECHNICAL DATA.....	193
PROGRAMMED MAINTENANCE.....	205
Scheduled maintenance table.....	206
Recommended products.....	209

RSV4 1100



Chap. 01
General rules

Foreword

NOTE

HALVE THE SERVICE INTERVALS INDICATED IF THE VEHICLE IS USED IN PARTICULARLY RAINY OR DUSTY CONDITIONS, ON POOR ROADS OR FOR HIGH PERFORMANCE RIDING.

NOTE

IF THE VEHICLE IS INVOLVED IN A FALL, WHETHER WHILE MOVING OR STATIONARY, ALWAYS TAKE IT TO AN OFFICIAL APRILIA DEALER, WHICH WILL CHECK IT THOROUGHLY TO MAKE SURE THAT IT IS UNDAMAGED AND IN PERFECT WORKING ORDER.

Motorcycle care

Aprilia recommends using quality products for cleaning the vehicle. The use of unsuitable products can damage vehicle components. For cleaning do not use solvents such as "nitro thinner", "cold cleaning agents", fuels or the like, or cleaning products that contain alcohol.

WASHING THE MOTORCYCLE

Aprilia recommends softening with plenty water and then carefully removing insects and stubborn stains before washing the vehicle.

To prevent stains, do not wash the motorcycle immediately after exposure to sunlight, and do not wash it in the sun.

If the vehicle is used during the winter months, be sure to frequently wash the motorcycle. To remove anti-icing salt sprayed on roads in the winter, wash the motorcycle with cold water immediately after use.

CAUTION

AFTER CLEANING YOUR MOTORCYCLE, THE EFFICIENCY OF THE BRAKING SYSTEM MAY BE TEMPORARILY AFFECTED DUE TO THE PRESENCE OF WATER ON THE FRICTION SURFACES. CONSIDER AN INCREASE IN BRAKING SPACE, OPERATE THE BRAKES REPEATEDLY TO RESTORE NORMAL CONDITIONS. CARRY OUT THE PRE-RIDE CHECKS BEFORE USE.



USE OF HOT WATER INTENSIFIES THE EFFECT OF THE SALT. USE ONLY PLENTY OF COLD WATER TO WASH AND REMOVE ANTI-ICING SALT



USE OF HIGH PRESSURE WASHING SYSTEMS (OR STEAM CLEANERS) CAN DAMAGE THE SEALS, OIL SEALS, BRAKING SYSTEM, ELECTRICAL SYSTEM AND THE SADDLE. DO NOT USE STEAM OR HIGH PRESSURE CLEANING SYSTEMS. DO NOT USE STEAM OR HIGH PRESSURE CLEANING SYSTEMS.

CLEANING OF SENSITIVE PARTS**BODYWORK**

To keep the motorcycle bright, wash it regularly, especially if used in areas with high levels of pollution or mud. Stubborn stains of tree resin, petrol, oil, brake liquid or bird droppings should be removed immediately, otherwise the stains risk becoming permanent.

After washing it is easy to identify marks and residual stains, remove them from the body using a soft cloth and brand-name, non-abrasive polish, and protect with a protective wax for cars. Periodic care, a thorough cleaning and regular protective wax for the bodywork preserves the aesthetic quality of the motorcycle over the long term.

PLASTIC COMPONENTS



IF THE PLASTIC COMPONENTS ARE CLEANED USING AGGRESSIVE AGENTS, THE SURFACE MAY BE DAMAGED. DO NOT USE CLEANING PRODUCTS CONTAINING ALCOHOL, SOLVENTS OR THAT ARE ABRASIVE FOR THE CLEANING OF PLASTIC PARTS. ROTARY BRUSHES OR SPONGES WITH HARD SURFACES CAN MAKE SCRATCHES

CHROME PARTS AND POLISHED METAL



TREAT THE PARTS MADE OF CHROME, ALUMINIUM OR POLISHED STEEL IN A SPECIAL MANNER. WASH THEM WITH PLENTY OF WATER AND CAR SHAMPOO, POLISH AND REGULARLY BRIGHTEN THEM WITH POLISH PASTE, PROTECT THEM WITH WAXES OR SUITABLE ACID-FREE PRODUCTS (E.G. VASELINE)

RADIATOR



IF THE VEHICLE IS USED IN WINTER ON ROADS TREATED WITH SALT, WASH THE RADIATOR FREQUENTLY TO PREVENT COSMETIC DAMAGE TO THE FINISH AND THE RISK OF ENGINE OVERHEATING. WASH WITH PLENTY OF WATER. WASH WITH A LOW PRESSURE JET OF WATER, USING A GARDEN HOSE FOR EXAMPLE.

RUBBER PARTS

Clean the rubber parts using water and mild shampoo (brand-name, suitable for car bodies)



THE USE OF SILICONE SPRAY TO CLEAN THE RUBBER SEALS MAY CAUSE DAMAGE. DO NOT USE OTHER PRODUCTS CONTAINING SILICON FOR CLEANING THE MOTORCYCLE

Carbon monoxide

If you need to keep the engine running while working on the vehicle, please ensure that you do so in an open or very well ventilated area. Never run the engine in an enclosed area. If you do work in an enclosed area, make sure to use a fume extraction system.

CAUTION



EXHAUST EMISSIONS CONTAIN CARBON MONOXIDE, A POISONOUS GAS WHICH CAN CAUSE LOSS OF CONSCIOUSNESS AND EVEN DEATH.

CAUTION



CARBON MONOXIDE IS ODOURLESS AND COLOURLESS, THEREFORE IT CANNOT BE DETECTED BY SMELL, SIGHT OR OTHER SENSES. DO NOT BREATHE IN EXHAUST FUMES UNDER ANY CIRCUMSTANCES.

Fuel

CAUTION



FUEL USED TO DRIVE EXPLOSION ENGINES IS HIGHLY INFLAMMABLE AND CAN BECOME EXPLOSIVE UNDER SPECIFIC CONDITIONS. IT IS THEREFORE RECOMMENDED TO CARRY OUT REFUELLING AND MAINTENANCE PROCEDURES IN A VENTILATED AREA WITH THE ENGINE SWITCHED OFF. DO NOT SMOKE DURING REFUELLING OR NEAR FUEL VAPOUR. AVOID ANY CONTACT WITH NAKED FLAME, SPARKS OR OTHER HEAT SOURCES WHICH MAY CAUSE IGNITION OR EXPLOSION.

DO NOT ALLOW FUEL TO DISPERSE INTO THE ENVIRONMENT.

KEEP OUT OF THE REACH OF CHILDREN.



IF THE VEHICLE FALLS OR IS ON A STEEP INCLINE FUEL CAN LEAK.

Hot components

The engine and the exhaust system components get very hot and remain in this condition for a certain time interval after the engine has been switched off. Before handling these components, make sure that you are wearing insulating gloves or wait until the engine and the exhaust system have cooled down.

Coolant

Coolant contains ethylene glycol, which may be flammable in certain conditions. Ethylene glycol burns with an invisible flame which may still cause burns.

CAUTION



TAKE PARTICULAR CARE NOT TO SPILL COOLANT ONTO HOT PARTS OR THE ENGINE AND EXHAUST SYSTEM; THE FLUID MAY CATCH FIRE AND BURN WITH INVISIBLE FLAMES. WHEN CARRYING OUT MAINTENANCE OPERATIONS, IT IS ADVISABLE TO WEAR LATEX GLOVES. WHILE POISONOUS, COOLANT HAS A SWEET TASTE WHICH MAKES IT EXTREMELY APPEALING TO ANIMALS. NEVER LEAVE COOLANT IN OPEN CONTAINERS WHERE IT MAY BE REACHED AND DRUNK BY AN ANIMAL.

KEEP OUT OF THE REACH OF CHILDREN.

NEVER REMOVE THE RADIATOR CAP WHILE THE ENGINE IS STILL HOT. COOLANT IS UNDER PRESSURE AND MAY CAUSE BURNS.

Used engine oil and gearbox oil

CAUTION



WHEN CARRYING OUT MAINTENANCE OPERATIONS, IT IS ADVISABLE TO WEAR PROTECTIVE IMPERMEABLE GLOVES.

THE ENGINE OR GEARBOX OIL MAY CAUSE SERIOUS INJURIES TO THE SKIN IF HANDLED FOR PROLONGED PERIODS OF TIME AND ON A REGULAR BASIS.

WASH YOUR HANDS CAREFULLY AFTER HANDLING OIL.

HAND THE OIL OVER TO OR HAVE IT COLLECTED BY THE NEAREST USED OIL RECYCLING COMPANY OR THE SUPPLIER.

DO NOT DISPOSE OF OIL IN THE ENVIRONMENT

KEEP OUT OF THE REACH OF CHILDREN.

Brake fluid



BRAKE FLUID MAY BE HARMFUL TO PAINTWORK, PLASTIC AND RUBBER. WHEN SERVICING THE BRAKING SYSTEM PROTECT THESE COMPONENTS WITH A CLEAN CLOTH. ALWAYS WEAR PROTECTIVE GOGGLES WHEN SERVICING THESE SYSTEMS. BRAKE FLUID IS EXTREMELY HARMFUL TO THE EYES. IN THE EVENT OF ACCIDENTAL CONTACT WITH THE EYES, RINSE THE EYES IMMEDIATELY WITH PLENTY OF COOL, CLEAN WATER AND SEEK IMMEDIATE MEDICAL ATTENTION.

KEEP OUT OF THE REACH OF CHILDREN.

Battery hydrogen gas and electrolyte

(IF AVAILABLE)

CAUTION



THE BATTERY ELECTROLYTE IS TOXIC, CORROSIVE AND, AS IT CONTAINS SULPHURIC ACID, MAY CAUSE BURNING IF IT COMES INTO CONTACT WITH

THE SKIN. WHEN HANDLING BATTERY ELECTROLYTE, WEAR TIGHT-FITTING GLOVES AND PROTECTIVE APPAREL. IN THE EVENT OF SKIN CONTACT WITH THE ELECTROLYTIC FLUID, RINSE WELL WITH PLENTY OF CLEAN WATER. IT IS PARTICULARLY IMPORTANT TO PROTECT YOUR EYES BECAUSE EVEN TINY AMOUNTS OF BATTERY ACID MAY CAUSE BLINDNESS. IN THE EVENT OF CONTACT WITH THE EYES, RINSE WITH PLENTY OF WATER FOR FIFTEEN MINUTES AND CONSULT AN EYE SPECIALIST IMMEDIATELY. THE BATTERY RELEASES EXPLOSIVE GASES; KEEP IT AWAY FROM FLAMES, SPARKS, CIGARETTES OR ANY OTHER HEAT SOURCES. ENSURE ADEQUATE VENTILATION WHEN SERVICING OR RECHARGING THE BATTERY.

KEEP OUT OF THE REACH OF CHILDREN.

BATTERY LIQUID IS CORROSIVE. DO NOT POUR OR SPILL ON PLASTIC COMPONENTS IN PARTICULAR. ENSURE THAT THE ELECTROLYTIC ACID IS COMPATIBLE WITH THE BATTERY BEING ACTIVATED.

Stand



ALTHOUGH THE MOTORCYCLE IS EQUIPPED WITH AN INSTRUMENT PANEL THAT SIGNALS THAT THE STAND IS DOWN, BEFORE STARTING MAKE SURE THE STAND IS COMPLETELY BACK IN POSITION.

DO NOT REST THE RIDER OR PASSENGER WEIGHT ON THE SIDE STAND.

Reporting of defects that affect safety

Unless otherwise specified in this Use and Maintenance Manual, do not remove any mechanical or electrical component.

CAUTION

SOME OF THE CONNECTORS ON THE VEHICLE MAY BE ACCIDENTALLY SWAPPED, AND MAY COMPROMISE NORMAL VEHICLE OPERATION AND/OR CAUSE IRREPARABLE DAMAGE TO PARTS OF THE VEHICLE IF INCORRECTLY INSTALLED.

RSV4 1100



Chap. 02
Vehicle

Arrangement of the main components (02_01, 02_02)



02_01



02_02

Key:

1. Left side fairing
2. Horn
3. Left headlamp with turn indicator
4. Steering damper
5. ASC control unit (Aprilia Suspension Control) (if available)
6. Left rear-view mirror
7. Top fairing
8. Clutch lever
9. Left hand switch
10. Fuel tank cap
11. Fuel tank
12. Left side fairing
13. Rider saddle

14. Battery
15. Secondary fuses
16. Main fuses
17. Left tail fairing
18. Taillight
19. Licence plate light
20. Rear left turn indicator
21. Tail fairing/ passenger saddle lock
22. Left hand passenger footrest
23. Side stand
24. Left hand rider footrest
25. Gearbox lever
26. AQS (Aprilia Quick Shift)
27. Left hand fairing lug
28. Engine oil radiator
29. Coolant radiator
30. Front left brake calliper
31. Left hand front brake disc
32. Right tail fairing
33. Tail fairing/ passenger saddle
34. Rear shock absorber
35. ABS control unit
36. Sensor box (inertia sensor platform)
37. ECU
38. Air filter
39. Right hand switch
40. Front brake fluid tank
41. Front brake master cylinder
42. Right rear-view mirror
43. Right headlamp with turn indicator
44. Coolant expansion tank
45. Front fork
46. Right hand front brake disc
47. Front tone wheel
48. Front ABS sensor
49. Front right brake calliper
50. Exhaust valve actuator
51. Right hand fairing lug

52. Engine oil level dipstick
53. Engine oil load cap
54. Rear brake lever
55. Right hand rider footrest
56. Exhaust valve
57. Rear brake master cylinder with oil reservoir
58. Rear brake disc
59. Rear tone wheel
60. Rear ABS sensor
61. Rear brake calliper
62. Exhaust muffler
63. Left hand passenger footrest

Dashboard (02_03)

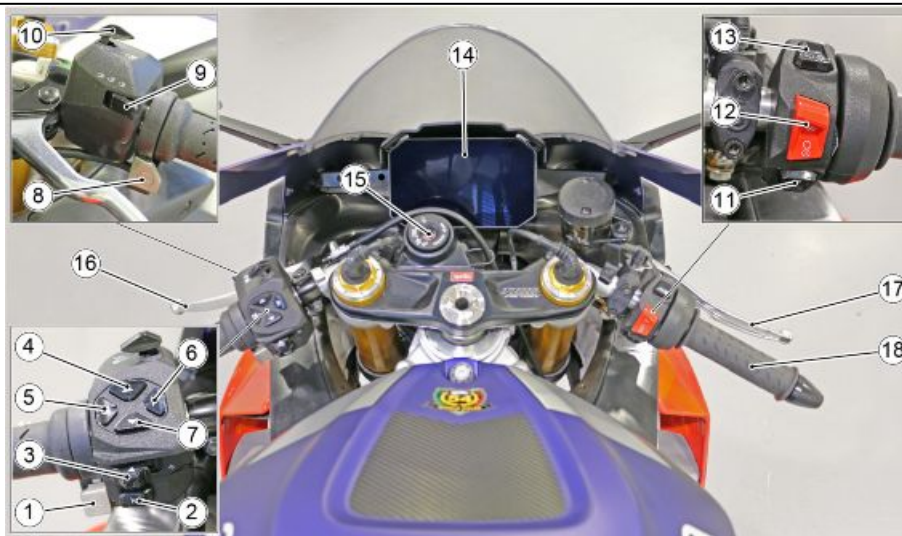

02_03

Key:

1. "+" button;
2. Horn button;
3. Turn indicator control;
4. Up button (MODE UP);
5. Set button (MODE SET);
6. Right button (MODE RIGHT);
7. Down button (MODE DOWN);
8. "-" button;
9. Low beam / high beam / flash high beam switch;
10. Cruise control/AWC selector (ROAD/NAVI mode) / PIT (RACE mode);
11. Riding mode button;
12. Engine start / stop switch;
13. Daytime running lights (DRL) / night lights switch;

14. Instruments and indicators;
15. Ignition switch / steering lock;
16. Clutch lever;
17. Front brake lever;
18. Throttle grip.

Digital instrument panel (02_04, 02_05)

Key:

1. Multifunctional digital display box.
2. Indicator lights.



02_04

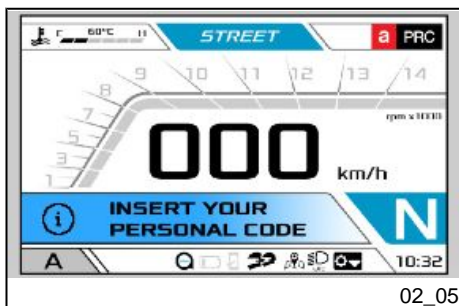

02_05

The dashboard has an immobilizer system which prevents start-up in case the system does not identify a key which has been stored before.

The vehicle is delivered to the customer with two pre-programmed keys. The dashboard accepts a maximum of four keys at the same time: contact an Authorised **Aprilia** Dealer to enable these keys or to disable a key that has been lost. Upon vehicle delivery, approximately ten seconds after the key is set to ON, the instrument cluster requests a personal five-digit code to be entered.

See the chapter "Advanced functions" for instructions on modifying the personal code

When the code is requested, a value (from 0 to 9) is shown for the first figure of the code. Use the MODE navigation buttons to modify the value. Press MODE SET briefly to confirm the value entered for the first figure of the code, and repeat the procedure to enter the remaining four figures of the code.

It is important to remember the personal code because:

- **the vehicle can be started if the immobilizer system is faulty**

- the dashboard need not be replaced should the ignition switch be changed
- new keys can be programmed

NOTE

IF THE PERSONA CODE IS NOT MEMORISED AND THE VEHICLE IS USED, THE MESSAGE DISAPPEARS AFTER 10 SECONDS BUT REAPPEARS WITH EACH KEY ON.

NOTE

THE FACTORY SET CODE IS COMPOSED OF FIVE ZEROES.



Light unit (02_06)

Key:

1. MI warning light, orange;
2. High beam indicator lamp, blue;
3. Cruise control indicator lamp, green;
4. ABS warning light, orange;
5. Left turn signal indicator lamp, green;
6. Right turn signal indicator lamp, green;
7. a-PRC warning light, orange;
8. DRL on indicator lamp, green;
9. Low fuel warning light, orange;
10. Neutral indicator lamp, green;
11. Immobilizer indicator lamp, red.

Digital Lcd display (02_07, 02_08, 02_09, 02_10, 02_11, 02_12, 02_13, 02_14, 02_15, 02_16)

NOTE

THE DASHBOARD INSTRUMENT PANEL IS EQUIPPED WITH A TWILIGHT SENSOR WHICH IS USED TO SWITCH AUTOMATICALLY BETWEEN DAY MODE AND NIGHT MODE, CHANGING THE BACKGROUND COLOUR ACCORDINGLY, IN RELATION TO AMBIENT LIGHT CONDITIONS.

IF THE "HEADLAMP MODE" FUNCTION (SEE PARAGRAPH "ADVANCED FUNCTIONS") IS SET TO "AUTO" (AUTOMATIC), THE TWILIGHT SENSOR IS ALSO USED TO SWITCH THE LOW BEAM HEADLIGHTS ON AND OFF AUTOMATICALLY.

- Turning the ignition switch to 'KEY ON', the following illuminate on the dashboard for about two seconds:
 - A dynamic graphic presentation.
 - All indicator lights.

Two different riding modes are available: ROAD and RACE.

ROAD mode is set by default. To change to RACE mode, the mode must be selected from the VEHICLE MENU.

Press and hold the MODE RIGHT button. The VEHICLE MENU is shown on the digital display. From the menu, press the MODE SET button briefly to select RACE mode.

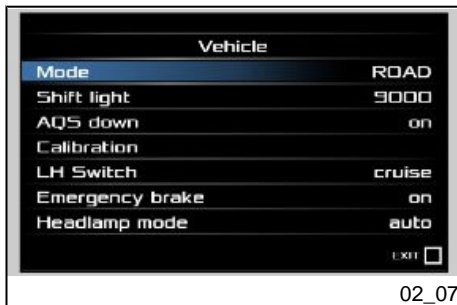

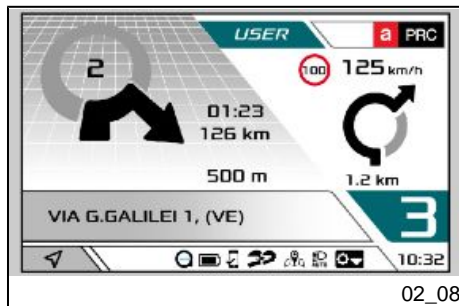

(where available)

On vehicles equipped with the APRILIA MIA electronic control unit, a navigation display mode may also be accessed by pressing and holding MODE RIGHT while in ROAD mode only .

Pressing and holding the button changes the digital display mode from ROAD to NAVI, and then to MENU.

Pressing and holding the MODE RIGHT button again cycles through the modes available

The following information is displayed in ROAD mode:

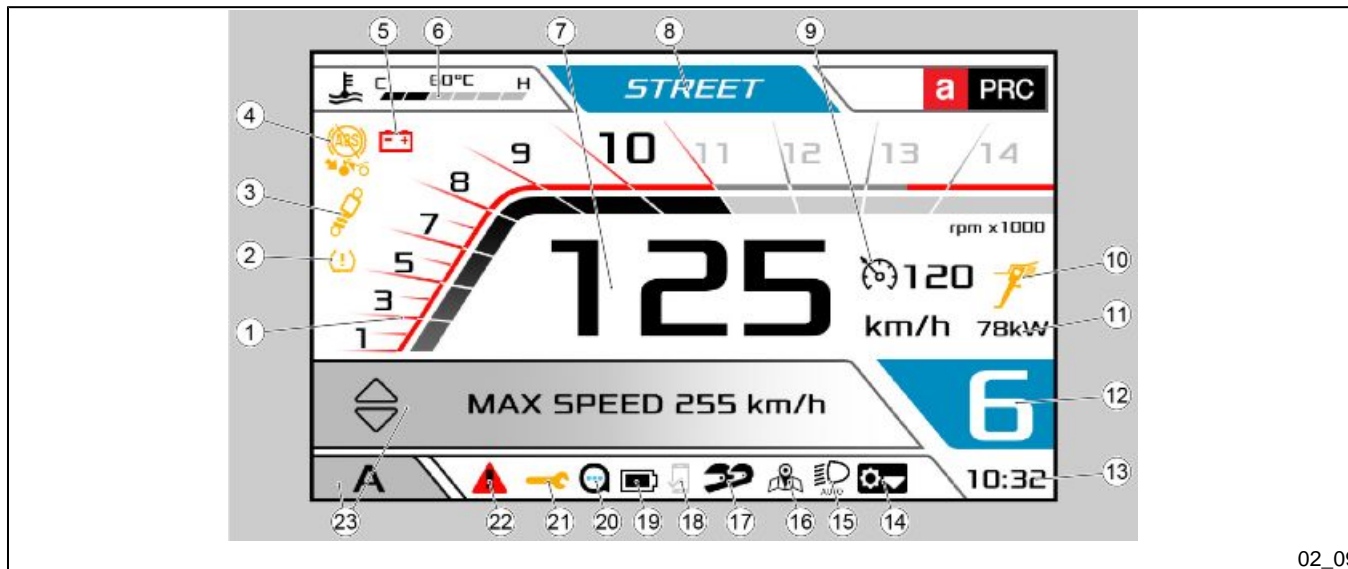

ROAD MODE - TRIP 1/TRIP 2

- 1) Engine speed (rpm x 1000);
- 2) Tyre pressure too low alarm (where provided);
- 3) Electronic suspension alarm (where provided);
- 4) Indication of the ABS system on the front wheel only when the control level is set to "1";
- 5) Low battery voltage warning icon;
- 6) Water temperature (viewable in °C or °F);
- 7) Speed (speedometer) (displayed in km/h or in mph);
- 8) Riding mode selected;
- 9) Cruise speed (speedometer dial icon with same symbol as respective indicator lamp is displayed when function is active);
- 10) Side stand down indicator;
- 11) Indication of the reduced power map presence;
- 12) Gear selected (displayed only with engine running and vehicle moving);
- 13) Clock (time viewable in 24 or 12 hour format, without AM / PM indication);
- 14) Downshift / reverse shift status (where implemented);
- 15) Automatic lights mode active;
- 16) GPS/Navigator (where active);
- 17) Rider/passenger intercom;
- 18) Audio transmission with smartphone for calling, sending vocal commands and playing music;
- 19) Battery level indicator relative to connected smartphone;
- 20) Data link with smartphone;

21) Service icon;

22) General Warning icon;

23) Trip computer log (TRIP A / TRIP B), phone, music, media player, system settings information a-PRC "T1" (ATC / AWC) or "T2" (ATC or ASC (where required) / AEM / AEB / ABS / ALC);

The following information is displayed in RACE mode:

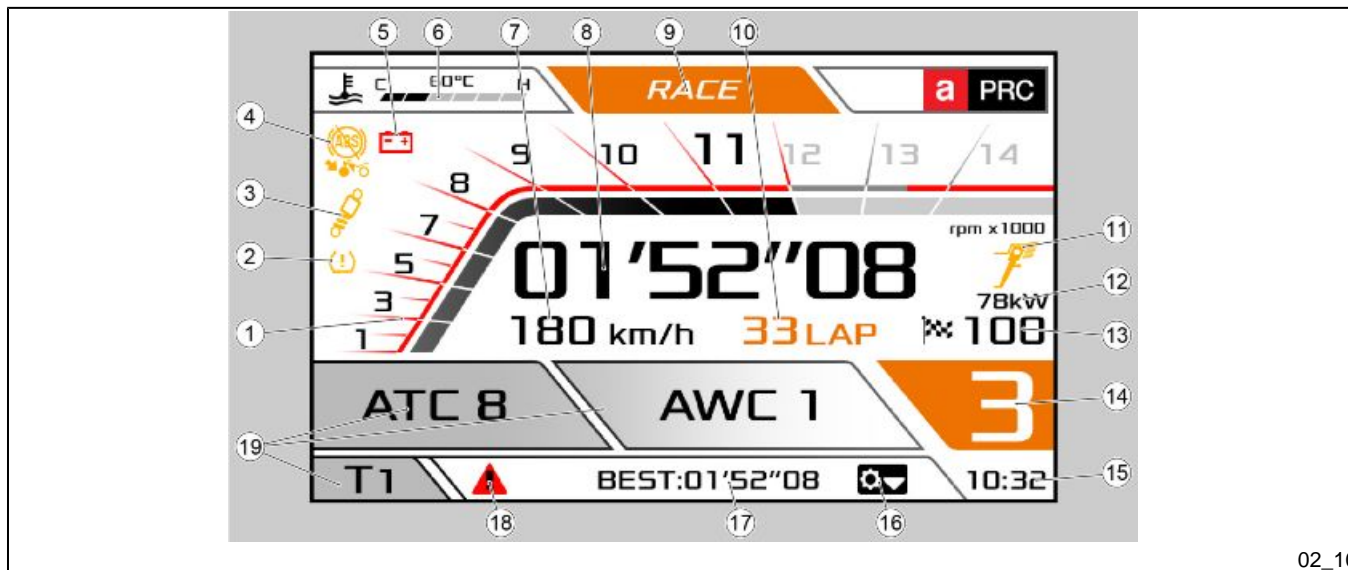

02_10

RACE MODE

- 1) Engine speed (rpm x 1000);
- 2) Tyre pressure too low alarm (where provided);
- 3) Electronic suspension alarm (where provided);
- 4) Indication of the ABS system on the front wheel only when the control level is set to "1";
- 5) Low battery voltage warning icon;
- 6) Water temperature (viewable in °C or °F);
- 7) Speed (speedometer) (displayed in km/h or in mph);
- 8) Stopwatch;
- 9) Riding mode selected;
- 10) Progressive LAPs;
- 11) Side stand down indicator;
- 12) Indication of the reduced power map presence;
- 13) PIT speed (chequered flag icon is displayed when function is active)
- 14) Gear selected (displayed only with engine running and vehicle moving);
- 15) Clock (time viewable in 24 or 12 hour format, without AM / PM indication);
- 16) Downshift / reverse shift status (where implemented);
- 17) Best lap;
- 18) General Warning icon;
- 19) System settings information a-PRC "T1" (ATC / AWC) or "T2" (ATC or ASC (where required) / AEM / AEB / ABS / ALC);

LAP TIMES			
Lap	Time	Speed	Angle
1	2'33"59	240	38
2	2'34"12	234	37
3	2'34"45	236	37
>4	2'33"20	244	39
5	2'35"18	232	35
6	2'34"49	237	37
7	2'35"31	230	34

02_11

LAP TIMER

The screen with the registered times can be displayed only in the RACE riding mode, within the specific menu section (see the paragraph "ADVANCED FUNCTIONS").

While the vehicle is moving, the timer is activated by briefly pressing the high beam flash button.

Timekeeping starts when the button is pressed. If the button is pressed again within 5 seconds after starting timekeeping, the lap timer is reset. After this period of time, when next pressed memorisation is carried out, with a consequent increase in the LAP number and the successive measurement starts.

Longer pressure on the high beam flasher switch, or when the speed returns to zero, the measurement is annulled, and the last measurement is shown on the display. Timekeeping starts again following the steps described above.

After 80 counts the acquisition of new counts will overwrite the first acquisition.

With the vehicle at a standstill and the timer paused, the LAP times can be viewed only in the specific screen within the MENU.

Press MODE UP or MODE DOWN briefly to scroll up or down through recorded LAP times.

Briefly press the MODE SET button to return to the RACE screen.

NOTE

PRESS AND HOLD MODE RIGHT TO CANCEL THE INDIVIDUAL LAP TIME HIGH-LIGHTED.

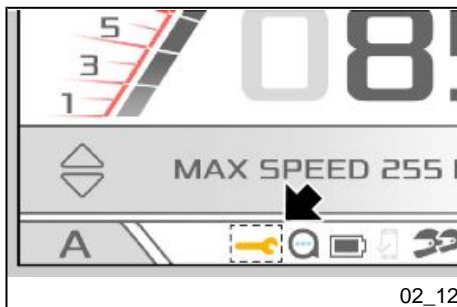

MAINTENANCE ICON

When a maintenance interval threshold is exceeded, an icon with a spanner is shown.

This indicator may be reset once the scheduled service has been completed by an **authorised Aprilia Dealer or service centre**.

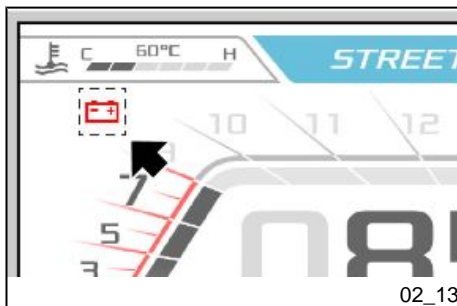

LOW BATTERY WARNING

The battery icon displayed at the top left of the digital display indicates a problem at the battery charging system.

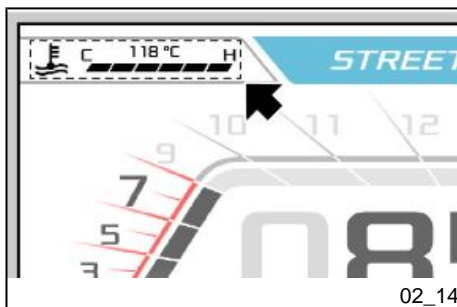

OVERTEMPERATURE WARNING

At engine coolant temperatures of 115 °C (239 °F) and higher, the temperature icon flashes and the general warning lamp is steadily lit.

CAUTION

STOP THE VEHICLE AND WAIT FOR THE ENGINE TO COOL.

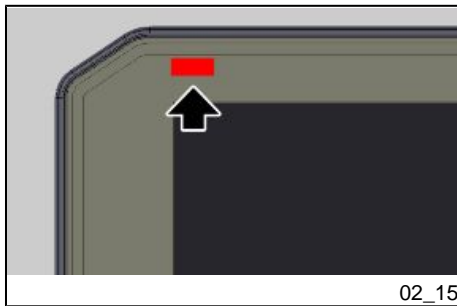

IMMOBILIZER

With the key in the "KEY OFF" position, the immobilizer indicator light flashes to indicate the activation of the system. To reduce battery consumption the light stops flashing after about 48 hours.

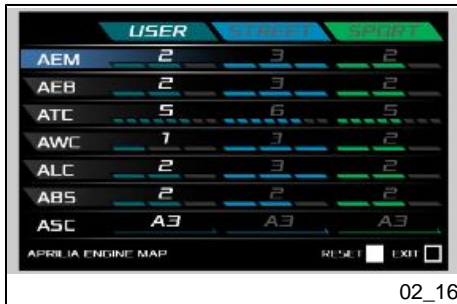

RIDING MODE SETTING SCREEN

From ROAD and RACE modes, a specific screen for setting the parameters of the riding mode may be accessed by pressing and holding the "RIDING MODE" button on the right hand handlebar control set.

See the paragraph "a-PRC system" for instructions on modifying parameters.

Press RIDING MODE or MODE SET briefly to exit the setting mode screen.

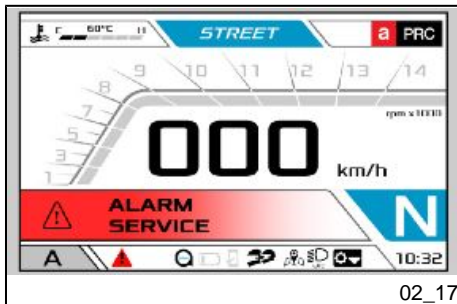

Alarms (02_17, 02_18, 02_19, 02_20, 02_21, 02_22, 02_23, 02_24, 02_25, 02_26, 02_27, 02_28)

In the event of a fault, the digital display will show the cause.

Take your vehicle as soon as possible to an Authorised **Aprilia Dealer**.

SERVICE ALARM

In case of failure found in the instrument panel or in the electronic control unit, the instrument panel signals the failure by displaying the **ALARM SERVICE** message and the red general warning icon comes on.



If there is an immobilizer failure at ignition, the dashboard requests you to enter a user code. If the code is entered correctly, the dashboard signals the failure by displaying the message SERVICE and the red general warning icon turns on.

URGENT SERVICE ALARM

A serious failure is signalled by a fast flashing (two flashes per second) of the general warning icon and by the message **ALARM URGENT SERVICE** on the digital display. Take your vehicle as soon as possible to an Authorised **Aprilia Dealer**. In these cases, the control unit activates a safety procedure that limits the vehicle performance so that the rider is able to reach an Authorised **Aprilia Dealer** at low speed. Depending on the type of failure, performance can be limited in three ways: a) by reducing the maximum torque produced; b) by keeping the engine at idle speed but slightly accelerated (during this operation, the throttle control is disabled); c) the engine rpm is steady at around 3000 rpm; Under these conditions the throttle control provides limited management of the torque.

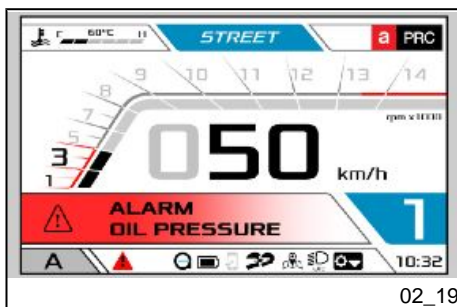

Oil failure

If a fault is detected with the oil pressure, the digital display shows the message **ALARM OIL PRESSURE**.

CAUTION

THE INDICATION IS ACCOMPANIED BY THE RED GENERAL WARNING ICON FLASHING.



STOP THE VEHICLE AND IMMEDIATELY CONTACT AN Approved Aprilia Dealer.

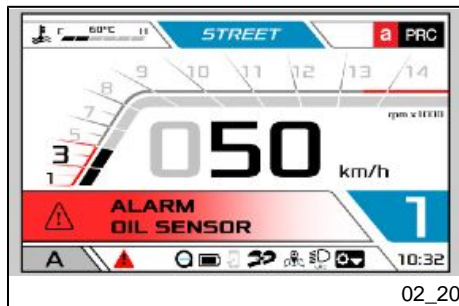

If a fault is detected with the oil pressure sensor, the digital display shows the message **ALARM OIL SENSOR**.

CAUTION

THE INDICATION IS ACCOMPANIED BY THE RED GENERAL WARNING ICON FIXED.

CAUTION

AS SOON AS POSSIBLE GO TO AN Authorised Aprilia Dealer.

Engine overheating alarm

The engine overheating alarm is activated when the temperature reaches 115 °C (239 °F). This is indicated by the lighting up of the red general alarm icon and by the flashing temperature symbol and the temperature itself on the digital display.

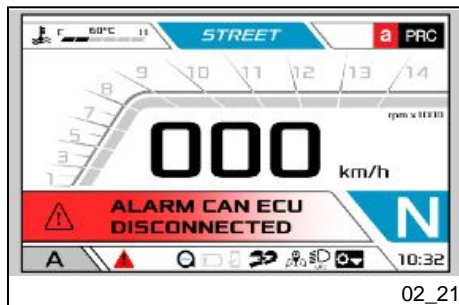

Electronic control unit disconnected alarm

If no connection is detected, the fault is indicated on the dashboard instrument panel by the message "**ALARM CAN ECU DISCONNECTED**" and by the red general alarm icon, which illuminates steadily.

NOTE

THE MESSAGE "ALARM CAN ECU DISCONNECTED" REMAINS ON THE DIGITAL DISPLAY AND THE HAZARD WARNING LIGHTS WILL CONTINUE TO FLASH (TO WARN OTHER ROAD USERS BEHIND THE VEHICLE OF POTENTIAL DANGER) UNTIL THE RIDER ACTIVATES THE RIGHT HAND TURN SIGNAL TO INDICATE THAT THEY ARE ABOUT TO PULL OVER AND STOP.

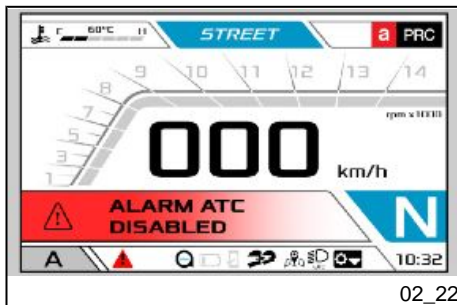

02_22

ATC alarm disabled

The ATC system disabling alarm is activated when there is a problem that can cause the system itself to be disabled.

CAUTION

DRIVE CAREFULLY AND IMMEDIATELY CONTACT AN Official Aprilia Dealer

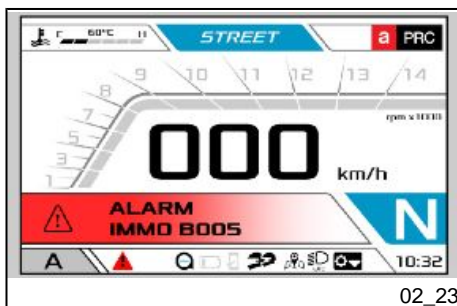

02_23

Immobilizer alarms

For immobilizer alarms, refer the specific paragraph "Immobilizer system operation". The error code may vary.

If there is an alarm, the user code must be entered to start the vehicle.

CAUTION

THE INDICATION IS ACCOMPANIED BY THE RED GENERAL WARNING ICON FIXED.

CAUTION

DRIVE CAREFULLY AND IMMEDIATELY CONTACT AN Official Aprilia Dealer

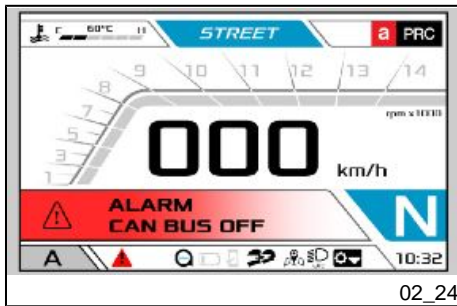

"CAN BUS OFF" electronic control unit disconnected alarm

If no connection is detected, the fault is indicated on the dashboard instrument panel by the message **ALARM CAN BUS OFF** and by the red general alarm icon, which illuminates steadily.



Headlamp disconnected alarm

If no connection is detected between the instrument panel and the headlight, the instrument panel itself signals the fault by displaying the message **ALARM CAN HLU** and by the red general alarm icon, which illuminates steadily.

NOTE

THE FRONT TURN INDICATORS ALSO FLASH WHILE THE ERROR "ALARM CAN HLU" IS ACTIVE ON THE DIGITAL DISPLAY.



Brakes stuck alarm

If constant pressure on one or both brake controls is detected for over 30 seconds while the vehicle is moving at a speed of 10 km/h (6 mph) or higher, the fault is indicated on the dashboard instrument panel by the message **WARNING BRAKE STUCK**.

If constant pressure on one or both brake controls is detected for over 60 seconds, the message **ALARM BRAKE STUCK** is shown on the dashboard instrument panel and the red general alarm icon illuminates steadily.

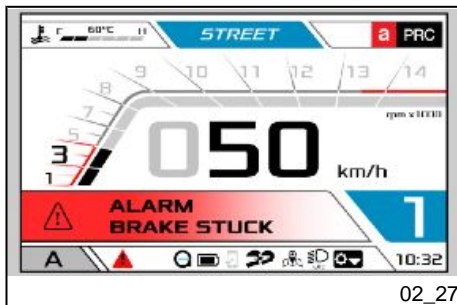

02_27

Electronic suspension ECU disconnection alarm (where provided)

If the electronic suspension ECU is not detected, the instrument panel signals the anomaly by displaying the message **ALARM CAN SCU DISCONNECTED**.

CAUTION

THE INDICATION IS ACCOMPANIED BY THE RED GENERAL WARNING ICON FIXED.



02_28

Mapping selection (02_29, 02_30, 02_31)

The engine control unit has 6 different selectable fly-by-wire throttle management "riding modes", with 3 for ROAD mode and 3 for RACE mode.

The currently selected riding mode is displayed in the upper centre part of the digital display.

ROAD/NAVI mode:

- USER
- STREET
- SPORT



02_29

USER riding mode is intended for non-performance oriented day-to-day use. Power and torque delivery is progressive and less aggressive.

STREET riding mode offers more aggressive throttle response, for more performance-oriented usage than in **USER** riding mode.

SPORT riding mode is fully customisable.

RACE mode:

- **TRACK 1**
- **TRACK 2**
- **RACE**

TRACK 1 riding mode is fully customisable.

TRACK 2 riding mode is fully customisable.

RACE riding mode is intended for performance-oriented usage, with less invasive traction control and engine brake effect settings.

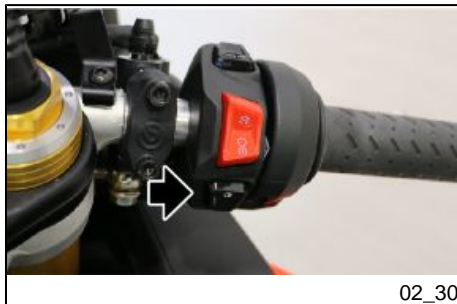

02_30

To cycle through the different riding modes, press the specific button on the right hand handlebar control set briefly.

CAUTION

DIFFERENT RIDING MODES MAY ALSO BE SELECTED ON THE FLY WHILE THE VEHICLE IS MOVING, PROVIDED THAT THE THROTTLE GRIP IS RELEASED.

RIDING MODES MAY ALSO BE PRESELECTED WHILE THE THROTTLE IS OPEN. IN THIS CASE, THE NEW MODE IS ONLY EFFECTIVELY IMPLEMENTED WHEN THE THROTTLE IS CLOSED AGAIN. THE ICON FLASHES WHEN A NEW MODE IS PRESELECTED AND PENDING IMPLEMENTATION.

CAUTION

IF THE THROTTLE IS OPENED WHILE THE NEW RIDING MODE IS SHOWN IN FLASHING MODE ON THE DISPLAY (I.E. MODE IS PRESELECTED ONLY AND PENDING IMPLEMENTATION BY THE ECU), THE PRESELECTED NEW RIDING MODE WILL NOT BE EFFECTIVELY IMPLEMENTED UNTIL THE THROTTLE GRIP IS RELEASED.

IF A NEW RIDING MODE IS SELECTED WHILE THE THROTTLE IS OPEN, THE NEW RIDING MODE REQUESTED WILL BE SHOWN IN FLASHING MODE UNTIL THE THROTTLE GRIP IS RELEASED.

CAUTION

IF THE REQUESTED RIDING MODE CONTINUES TO BE DISPLAYED IN FLASHING MODE, THIS MEANS THAT NOT ALL THE CONDITIONS NECESSARY FOR IMPLEMENTATION OF A NEW MODE ARE MET, E.G.: THROTTLE OPEN, CLUTCH LEVER IN USE ETC.

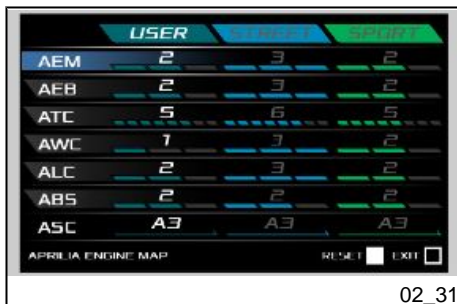

02_31

To gain access to the riding mode settings screen, press and hold the relative button on the right hand lights switch.

The only riding modes with user-modifiable parameters are: SPORT, for the ROAD/NAVI modes, and TRACK 1 / TRACK 2 for the RACE mode.

Using the MODE UP or MODE DOWN buttons the desired parameter may be selected and by briefly pressing the MODE RIGHT button the intervention value can be increased.

Once the maximum level is reached, the setting will restart from the minimum intervention.

After setting the parameters as desired, press MODE SET briefly to exit the screen.

Press and hold MODE SET to restore the factory settings.

NOTE

THE NAME OF THE SELECTED FUNCTION AND A BRIEF DESCRIPTION OF WHAT IT DOES ARE SHOWN AT THE BOTTOM OF THE DIGITAL DISPLAY.

CAUTION

DISABLING THE ATC SYSTEM ALSO AUTOMATICALLY DISABLES THE AWC SYSTEM.

AFTER DISABLING THE ATC SYSTEM, IT IS NOT POSSIBLE TO MODIFY THE PARAMETERS OF AND REACTIVATING THE AWC SYSTEM SEPARATELY.

THE AWC SYSTEM IS AUTOMATICALLY REACTIVATED WHEN THE ATC SYSTEM IS REACTIVATED.

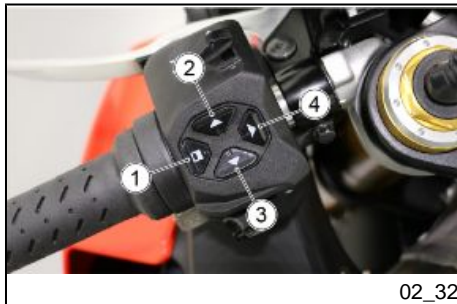

Control buttons (02_32, 02_33, 02_34, 02_35, 02_36, 02_37, 02_38, 02_39, 02_40, 02_41, 02_42, 02_43, 02_44, 02_45, 02_46, 02_47, 02_48, 02_49, 02_50, 02_51, 02_52, 02_53, 02_54)

The system tabs can be navigated using the control buttons on the left hand light switch.

In the ROAD/NAVI drive modes the following data can be viewed: the A/B trip log information, the "T1" / "T2" a-PRC system intervention level information and if the APRILIA MIA ECU is present, the phone, music and media information as well.

In the RACE drive mode the following data can be viewed: the A/B trip log information and the "T1" / "T2" a-PRC system intervention level information

The navigation buttons are as follows:

1. **MODE SET** (selection / exit / reset, with a long press)
2. **MODE UP** (up)
3. **MODE DOWN** (down)
4. **MODE RIGHT** (right / modification)

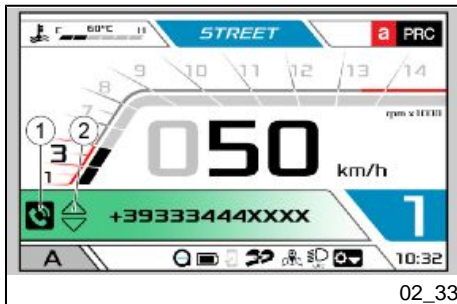

A number of different symbols (such as the examples (1) and (2) shown in the figure) may be displayed in the popup space.

- Where shown as a solid shape (1), the symbol indicates that it is necessary to press and hold the relative control for the function described.
- Where shown as an outline only (2), the symbol indicates that it is necessary to press the relative control briefly and release for the function described.

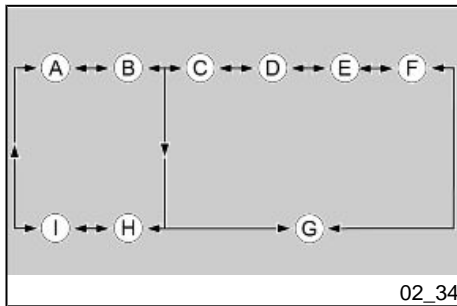

Repeated brief presses on the "MODE RIGHT" button will cyclically show:

- A) Trip log A.
- B) Trip log B.
- C) Phone information. (if applicable)
- D) Music information. (if applicable)
- E) Media information. (if applicable)
- F) Tyre pressure information. (if applicable)
- G) Navigation destination. (if applicable)
- H) "T1" a-PRC system intervention level information
- I) "T2" a-PRC system intervention level information



A / B) Trip log A and B (displayed in ROAD / NAVI modes only)

Two trip logs are available.

Press "MODE UP" or MODE DOWN" briefly to cycle through the following information on the digital display:

- ODOMETER.
- TRIP ODOMETER.
- TRIP TIME.
- MAXIMUM SPEED.
- AVERAGE SPEED.
- AVERAGE FUEL CONSUMPTION.
- INSTANTANEOUS FUEL CONSUMPTION.

From any of the following view modes: TRIP ODOMETER, TRIP TIME, MAXIMUM SPEED, AVERAGE SPEED or AVERAGE FUEL CONSUMPTION, press and hold MODE SET to reset all the values logged in the currently active TRIP LOG.

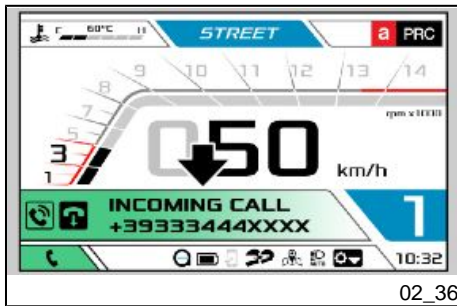

C) Phone information (displayed in ROAD / NAVI modes only) (where applicable)

Information relative to phone calls is displayed in this menu, such as:

- Active call.
- Incoming call.
- Outgoing call.
- Call ended.
- Voice control active.
- Call log.

See the chapter "ADVANCED FUNCTIONS" for more details.



D) Music information (displayed in ROAD / NAVI modes only) (where applicable)

Information relative to audio playback is displayed in this menu, such as:

- Track playing.
- Playback paused.

See the chapter "ADVANCED FUNCTIONS" for more details.

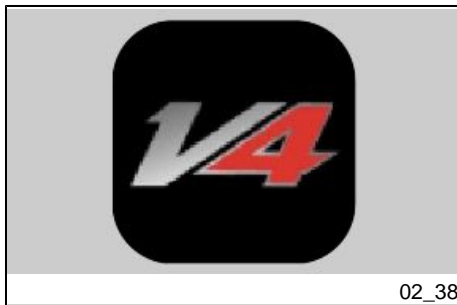

E) Media information (displayed in ROAD / NAVI modes only) (where applicable)

The vehicle is equipped with the "APRILIA MIA" accessory, which communicates with the smartphone via Bluetooth. Using the special "APRILIA" application installed on the smartphone, it is possible to exchange data with the vehicle and manage multimedia contents. Once a connection is established correctly between the control unit and the smartphone, the following functions can be directly managed by the digital display of the vehicle:

- manage phone calls;
- manage audio playback;
- GPS navigation.



02_39

The "MIA PAIRING" menu contains 3 functions:

- pairing phone;
- pairing handset 1;
- pairing handset 2.

After selecting "PAIRING PHONE" (only available with vehicle stationary), press MODE SET briefly to enable discoverable mode.



02_40

Enable the bluetooth search on your smartphone, select the "BT-ROUTER" device and, if required, enter the password "0000" and press on pair. The message "PAIRING ENABLED", confirming that pairing with the smartphone is enabled, appears on the digital display

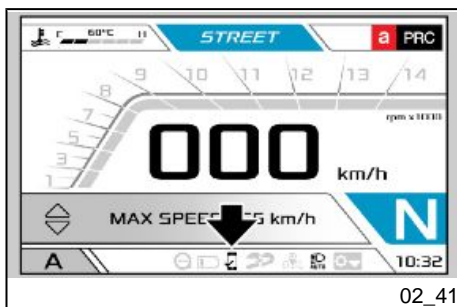

02_41

The "BT-ROUTER" device will be visible in the list of associated devices on the smartphone. Wait for the digital display to automatically connect the smartphone. **Do NOT force the connection from the telephone.** The smartphone icon on the display indicates active communication. **When requested, allow phone book and notifications sharing.** These enabling operations are necessary to display the caller's name on the display.

NOTE

UPON THE FIRST PAIRING BETWEEN THE DISPLAY AND SMARTPHONE, MORE TIME MAY BE REQUIRED FOR THE SYNCHRONIZATION OF THE PHONE BOOK.

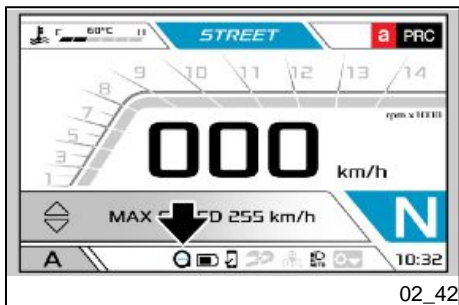

THE CONNECTION BETWEEN THE SMARTPHONE AND VEHICLE WILL BE SIGNALLED BY THE LIGHTING OF THE SMARTPHONE ICON ON THE DISPLAY.

CAUTION

TO PAIR WITH HANDSET 1 AND 2, REPEAT THE PROCEDURE DESCRIBED ABOVE, ENABLING BLUETOOTH DISCOVERABLE MODE FROM THE RESPECTIVE DEVICES.

CONNECTION BETWEEN THE APPLICATION AND THE DIGITAL DISPLAY

Search for the «APRILIA» application from the Play Store or App Store, and install it. Register your account by following the instructions. Select "allow" for the position and notifications management requests.

PAIRING A BLUETOOTH HEADSET FROM THE APP

Multimedia functions may be accessed using the MODE buttons if a bluetooth headset is paired with the digital display from the "APRILIA" app. After pairing it will be possible to answer or reject calls, activate voice commands and control the music on the smartphone.

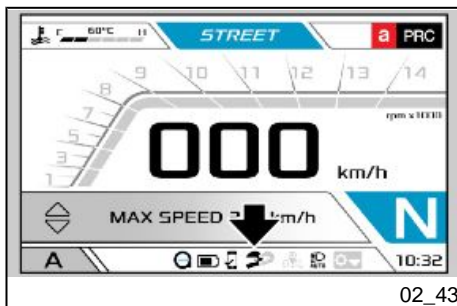

02_43

Activate the **"pairing"** mode of the bluetooth headset to be paired (refer to the instructions of the device itself). Press the Bluetooth icon on the main screen of the **"APRILIA"** application and perform a new search for devices until the headset is displayed. Select the bluetooth headset, check the **"Handsfree/driver headset"** option and press **"Pair"**. Successful pairing is indicated by the helmet icon displayed on the digital display. If the pairing is not successful, perform a new search.

Repeat the operation to connect a second device also. If this pairing procedure is successful, the 2nd helmet icon will be highlighted in black on the digital display.



02_44

No multimedia function can be managed from the handlebar of the vehicle if there is no bluetooth headset, or if the headset is directly connected to the smartphone. **The pairing of the bluetooth headset to the vehicle is only possible via the "APRILIA" application and this must be connected to the vehicle in order to correctly use the multimedia functions of the system. For this reason, the headsets that automatically connects to the smartphone are not compatible (Ex: Apple AirPods).**

If pairing between Smartphone and Vehicle is not successful, proceed as follows:

- restart the smartphone;
- turn the ignition key to **"OFF"** and then to **ON"**; wait for the animation on the display to end.

If the smartphone icon on the display is not illuminated after approximately 1 minute, proceed as follows;

- open **"APRILIA"** and select **"Connect"**;
- select your vehicle from the list of suggestions and follow the instructions on the device;

- once the Application is connected, select the Bluetooth icon that appears on the main screen;
- open the Bluetooth devices menu;
- select "**Configure**" and delete all paired devices, leaving the current device as the last one;
- make sure that the application icon on the display is off;
- turn the ignition key to "**OFF**" and then to "**ON**", then wait until the animation on the screen ends;
- the display must show the pop up "**No connected device**";
- repeat the pairing procedure from the start.

NOTE

PLEASE NOTE THAT TO CONNECT THE APP TO THE VEHICLE AGAIN, THE FOLLOWING WILL BE NECESSARY:

- **ON iOS, DELETE THE PREVIOUSLY INSTALLED APP AND REINSTALL IT.**
- **ON ANDROID, SIMPLY DELETE THE APPLICATION DATA FROM THE APP MANAGEMENT MENU (THIS WILL RETURN THE APPLICATION TO THE INITIAL CONDITION AND THE LOGIN AND FIRST CONNECTION TO THE VEHICLE MUST BE PERFORMED AGAIN).**
- **IN CASE OF CONNECTION TO A NEW VEHICLE, IT IS NECESSARY TO REMOVE THE PREVIOUS BT-ROUTER FROM THE ASSOCIATED DEVICES.**

NOTE

IT IS RECOMMENDED TO PAIR A MAXIMUM OF 2 SMARTPHONES AND 2 HEADSETS TO THE SAME VEHICLE, TO OPTIMIZE THE OPERATION OF THE SYSTEM.

IN CASE OF PAIRING THE SECOND SMARTPHONE, NOTE THAT THE SECOND ONE WILL REQUIRE A LONGER TIME (MORE THAN 30 SECONDS) TO CONNECT TO THE "BT-ROUTER". ONCE THE SMARTPHONE IS CONNECTED TO THE "BT-ROUTER", THE OPERATING SYSTEM WILL REQUEST ACCESS TO THE PHONE BOOK AND TO THE NOTIFICATIONS; ACCEPT TO DISPLAY THE NAMES OF THE CALLERS ON THE DISPLAY.

Required operation for iOS 10.0 versions or higher

If the "BT-ROUTER" device does not automatically request permission to share notifications, the following procedure is necessary:

- Enter the menu: "Settings" > "Bluetooth" > "Phone devices";
- select "BT-ROUTER", select "Info", enable the options manually.

INTERCOM AND VOCAL COMMANDS MANAGEMENT

The "APRILIA" system manages the connection between the intercom and smart-phone upon activation by the user.



FOR SAFETY REASONS, IT IS RECOMMENDED TO CARRY OUT THE ACTIVATION / DEACTIVATION PROCEDURES WITH THE VEHICLE AT A STANDSTILL.

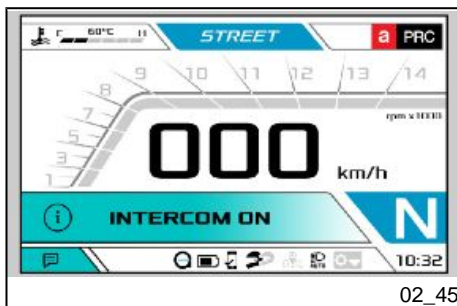

To activate the "INTERCOM" function, press MODE SET from the "Media information" screen.

A pop-up with the message "INTERCOM ON" will be shown on the digital display.

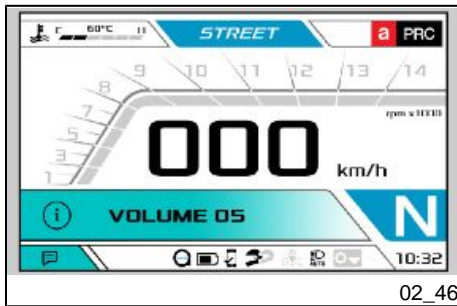

02_46

The audio volume may now be controlled by pressing and holding MODE UP or MODE DOWN.

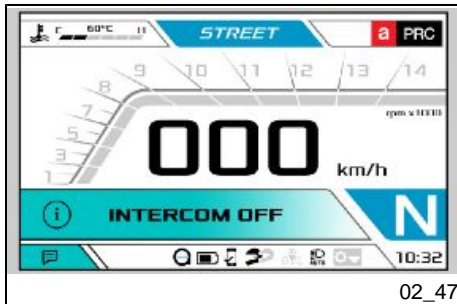

02_47

Pressing MODE SET briefly again deactivates the connection. The state "INTERCOM OFF" is now shown on the digital display.



02_48

To activate the "VOICE" function, which allows the user to access and use functions of their smartphone with voice commands from the handset (e.g. via Siri or Google Assistant), select the function with the MODE UP or MODE DOWN buttons and then press MODE SET briefly.



THE "VOICE" FUNCTION CANNOT BE ACTIVATED IF THE "INTERCOM" FUNCTION IS ALREADY ACTIVATED.

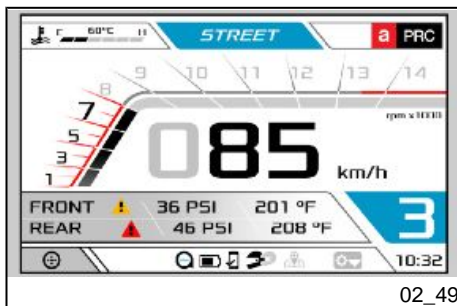

F) Tyre pressure information (displayed in ROAD and NAVI modes only) (where applicable)

Select this screen to view information relative to tyre pressure and temperature.

G) Navigation destination (where applicable)

Select this screen to view the destination for the navigation system entered via the smartphone.

«APRILIA MIA» SYSTEM MESSAGES

The «APRILIA MIA» system communicates with the user through messages that can be viewed on the graphic panel of the digital display. Depending on the message type, the graphic panel shows the icon, colours and the specific message.

The following information is displayed:

- Information messages related to the infotainment system.

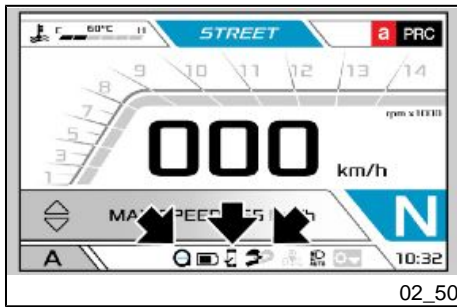

CALL MANAGEMENT

To use phone features, view caller notifications and identifiers, it is necessary to:

- pair the smartphone with the "APRILIA MIA" system via bluetooth as described above;
- install the "APRILIA" app on your smartphone and access your account from the app or from the dashboard instrument panel;
- pair a bluetooth headset with the "APRILIA MIA" system from the "APRILIA" app or from the dashboard instrument panel;
- allow sharing of the phonebook and notifications when the smartphone is paired with the "APRILIA MIA" system.

NOTE

WHEN A SMARTPHONE CONNECTS WITH THE "APRILIA MIA" SYSTEM (BT-ROUTER), AUDIO IS AUTOMATICALLY ROUTED TO THE APRILIA MIA SYSTEM. IF A HEADSET IS NOT CONNECTED TO THE "APRILIA MIA" SYSTEM YOU CAN NOT MANAGE THE AUDIO OF CALLS OR LISTEN TO MUSIC, THEREFORE YOU NEED TO MANUALLY DIRECT THE AUDIO OF YOUR SMARTPHONE TOWARDS THE DESIRED DEVICE (E.G. SPEAKERS / MICROPHONE OF THE SMARTPHONE).

The following information is shown in the relative area on the digital display:

- call in progress;
- call ended;
- voice control active;
- incoming call;
- outgoing call;
- call log.

Press and hold MODE SET to enable voice commands.

Press MODE DOWN or MODE UP briefly to scroll through the log of all calls (missed calls, calls made, outgoing calls made with no reply).

Select the required log entry and then press and hold MODE SET to call the relative contact.

MODE SELECTOR FUNCTIONS FOR CALL MANAGEMENT

Accept incoming call	PRESS MODE SET BRIEFLY
End an active call	PRESS AND HOLD MODE SET
Reject incoming call	PRESS AND HOLD MODE SET
Cancel outgoing call	PRESS AND HOLD MODE SET
Activate volume control (with call in progress)	PRESS AND HOLD MODE UP OR MODE DOWN
Increase volume (with call in progress)	PRESS MODE UP BRIEFLY
Lower volume (with call in progress)	PRESS MODE DOWN BRIEFLY

MANAGING A SECOND CALL

If the smartphone paired with the "APRILIA MIA" system is capable of receiving a second incoming call, a number of functions for managing a second call are available.

A popup appears on the digital display showing the identification details of the current and of the new incoming call are displayed in alternation (at intervals of approximately 1 second).

FUNCTIONS OF MODE SELECTOR FOR MANAGING SECOND CALL

Accept incoming call and put current call on hold PRESS MODE SET BRIEFLY

Reject incoming call and continue current call PRESS AND HOLD MODE SET

Switch between call 1 and call 2 PRESS MODE SET BRIEFLY

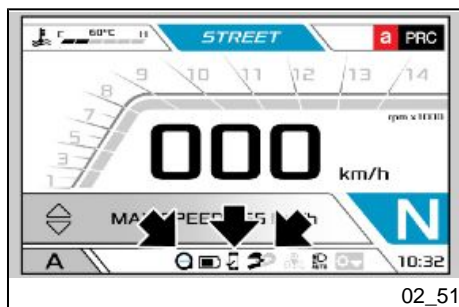

MUSIC PLAYBACK MANAGEMENT

To use the functions of the music player, the following must be performed:

- pair the smartphone with the "APRILIA MIA" system via bluetooth as described above;
- install the "APRILIA" app on your smartphone and access your account from the app or from the dashboard instrument panel;
- pair a bluetooth headset with the "APRILIA MIA" system from the "APRILIA" app or from the dashboard instrument panel.

The corresponding three icons are shown on the digital display.

NOTE

WHEN A SMARTPHONE CONNECTS WITH THE "APRILIA MIA" SYSTEM (BT-ROUTER), AUDIO IS AUTOMATICALLY ROUTED TO THE APRILIA MIA SYSTEM. IF A HEADSET IS NOT CONNECTED TO THE "APRILIA MIA" SYSTEM YOU CAN NOT MANAGE THE AUDIO OF CALLS OR LISTEN TO MUSIC, THEREFORE YOU NEED TO MANUALLY DIRECT THE AUDIO OF YOUR SMARTPHONE TOWARDS THE DESIRED DEVICE (E.G. SPEAKERS / MICROPHONE OF THE SMARTPHONE).

The following information appears on the digital display:

- track playing;

- playback paused;
- playback interrupted.

Use the MODE buttons to manage audio playback as shown in the table:

MODE SELECTOR FUNCTIONS FOR MUSIC MANAGEMENT

Play track	PRESS MODE SET BRIEFLY
Activate volume control (with call in progress)	PRESS AND HOLD MODE UP OR MODE DOWN
Increase volume (with call in progress)	PRESS MODE UP BRIEFLY
Lower volume (with call in progress)	PRESS MODE DOWN BRIEFLY
Next music track	PRESS MODE UP BRIEFLY
Previous audio track	PRESS MODE DOWN BRIEFLY
Activate Siri	PRESS AND HOLD MODE SET

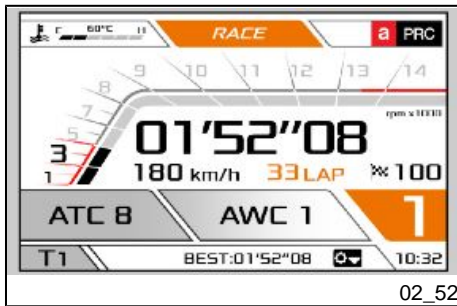

H) "T1" a-PRC system intervention level information

When this tab is selected, the ATC and AWC system intervention levels will be displayed.

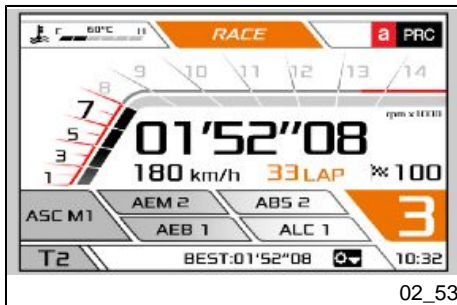

I) "T2" a-PRC system intervention level information

Select this screen to view the ATC or ASC (if available), AEM, AEB, ABS, ALC system intervention levels.



From the screen that shows the "T2" information, briefly press the MENU SET to gain direct access to the configuration menu of the ASC MODE displayed.

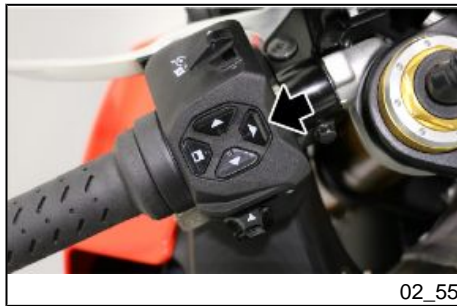

Advanced functions (02_55, 02_56, 02_57, 02_58, 02_59, 02_60, 02_61, 02_62, 02_63, 02_64, 02_65, 02_66, 02_67, 02_68, 02_69, 02_70, 02_71, 02_72, 02_73, 02_74, 02_75, 02_76, 02_77, 02_78, 02_79, 02_80, 02_81, 02_82, 02_83, 02_84, 02_85, 02_86, 02_87, 02_88, 02_89, 02_90, 02_91, 02_92, 02_93, 02_94, 02_95, 02_96, 02_97, 02_98)

The configuration menu may be accessed, with the vehicle stationary, by pressing and holding MODE RIGHT directly from the main screen.

The menu structure, which varies depending on the selected riding mode, is illustrated in the following flow diagram.

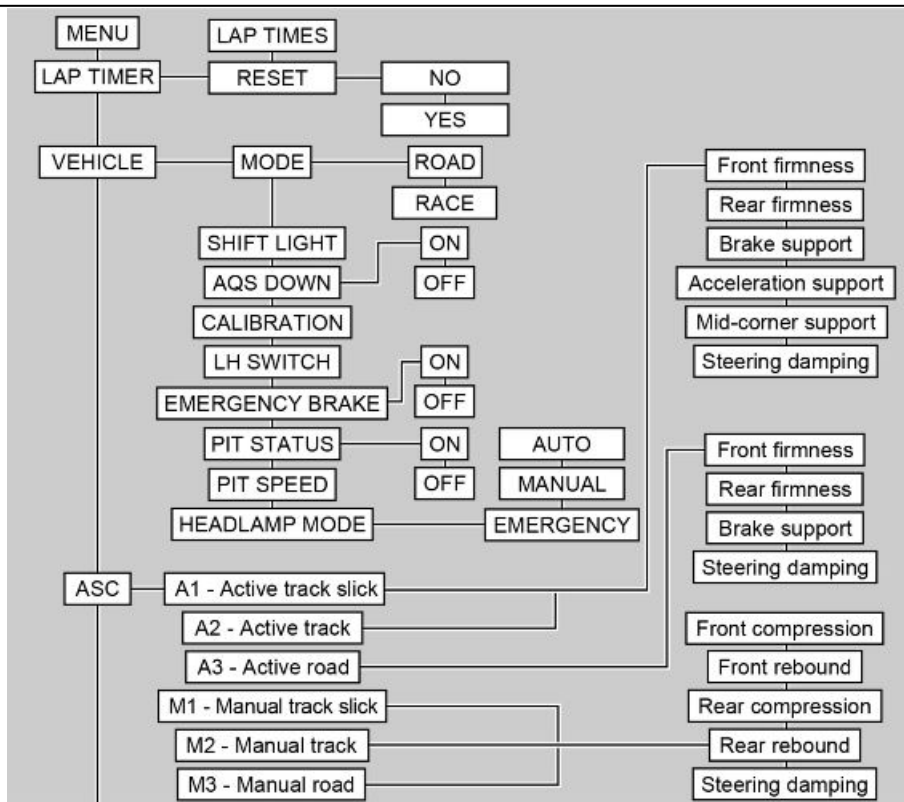

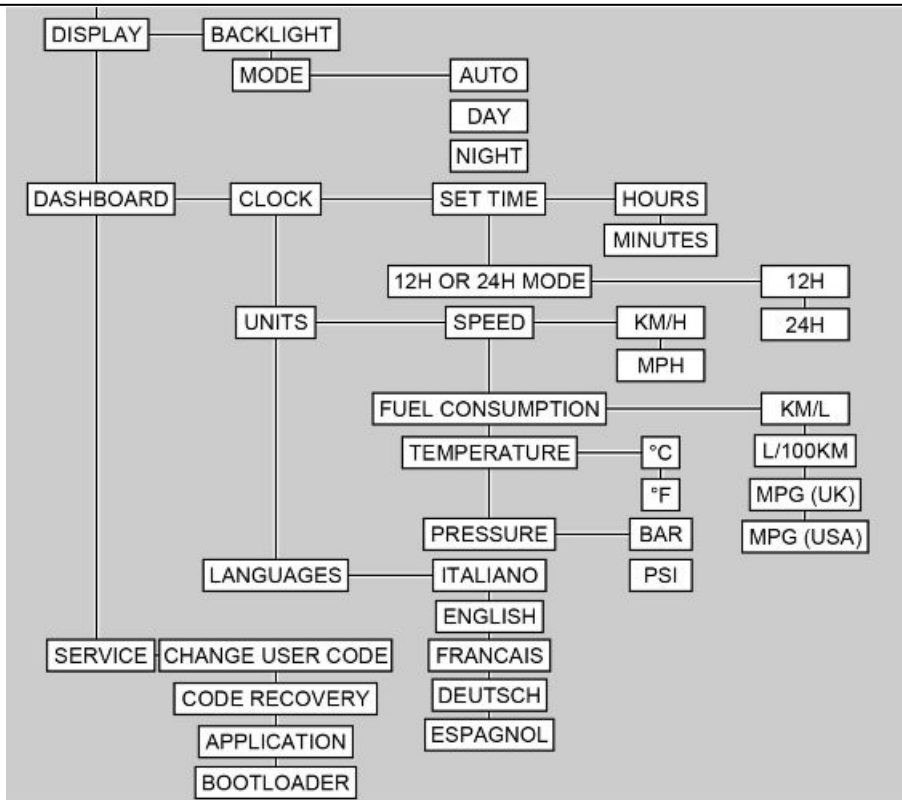

02_57



The menu is composed of the following entries:

- 1) Lap timer (in RACE mode only)
- 2) Vehicle
- 3) ASC (if supplied)
- 4) Display
- 5) Dashboard (Dashboard)
- 6) Service (Service)



1) Lap timer (in RACE mode only)

The "Lap timer" menu contains the following options:

- 1.1) Lap times
- 1.2) Reset

The functions available in the "Lap timer" menu are explained in the following paragraphs.



1.1) Lap times (in RACE mode only)

Press MODE RIGHT briefly to access the "Lap times" functions.

This function allows you to display the memorised laps and the relative specific information, including:

- Number of the lap.
- Lap time.
- Maximum speed.
- Maximum lean angle.

Use the MODE UP and MODE DOWN buttons to scroll through all the laps times recorded.

The ">" before the lap number identifies the best memorised time.

Press and hold MODE RIGHT to reset the individual highlighted lap time.

Press MODE SET briefly to go back to the "Lap times" menu.

LAP TIMES			
Lap	Time	Speed	Angle
1	2'33"59	240	38
2	2'34"12	234	37
3	2'34"45	236	37
>4	2'33"20	244	39
5	2'35"18	232	35
6	2'34"49	237	37
7	2'35"31	230	34

02_61

1.2) Reset (clear times) (in RACE mode only)

This function resets all lap times stored in memory. This function is composed of the following entries:

1.2.1) No

1.2.2) Yes

The functions available in the "Reset" (Clear times) menu are described in the following paragraphs.

Press MODE SET briefly to go back to the "Lap timer" menu.



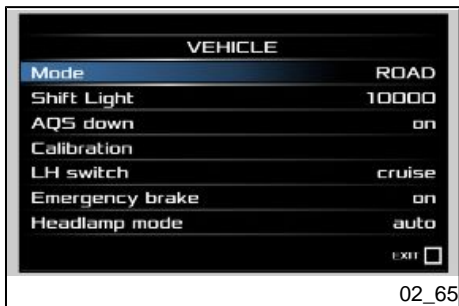
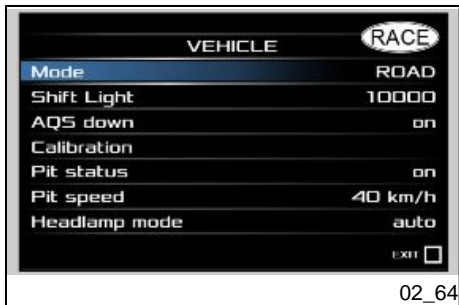
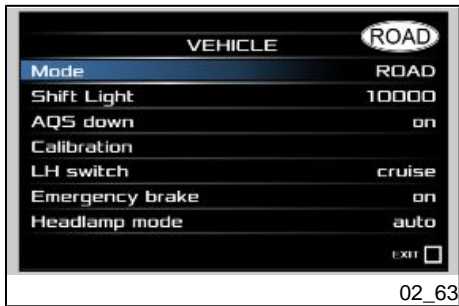

2) Vehicle

The "Vehicle" menu contains the following options:

- 2.1) Mode (Mode)
- 2.2) Shift light (Shift light)
- 2.3) AQS down
- 2.4) Calibration (Calibration)
- 2.5) LH Switch (only in the ROAD/NAVI mode)
- 2.6) Emergency brake (brake light) (in ROAD/NAVI mode only)
- 2.7) PIT status (in RACE mode only)
- 2.8) Pit speed (pit limiter speed) (in RACE mode only)
- 2.9) Headlamp mode

The functions available in the "Vehicle" menu are described in the following paragraphs.

Press MODE SET briefly to go back to the main MENU.

2.1) Mode (Mode)

This function lets the user choose from the two base display modes ROAD and RACE.

Briefly press the MODE RIGHT button to change the display type. Further presses will cyclically show the modes.

Press MODE SET briefly to go back to the main MENU.

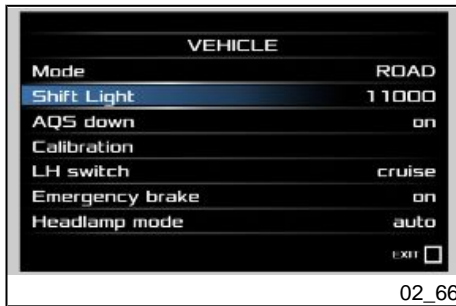

2.2) Shift light (Shift light)

This function is used to set the rpm threshold above which the engine rpm bar and the immobilizer indicator light flash.

Briefly press on the MODE right button to increase the threshold.

Once the maximum rpm is exceeded, the threshold restarts from 6,000 rpm.

Press MODE SET briefly to exit edit mode.

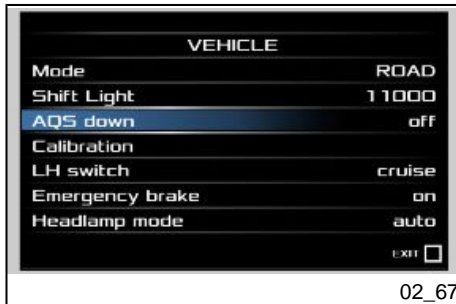

2.3) AQS Down

This function may be used to enable or disable the automatic matching system allowing downshifts without using the clutch.

Briefly press the button to change the activation state.

Further presses on the MODE RIGHT button will cyclically change the function.

Press MODE SET briefly to go back to the main MENU.

AQS ICON KEY:

- Black icon (day mode)/White icon (nigh mode) = AQS enabled
- Grey icon = AQS disabled by user
- Orange icon = AQS disabled by system
- Red icon = AQS system malfunction

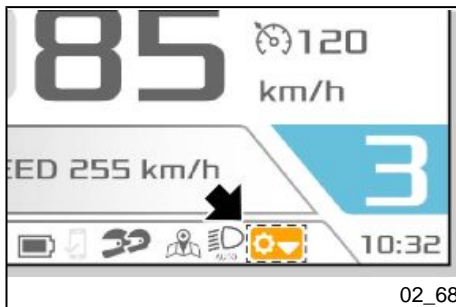

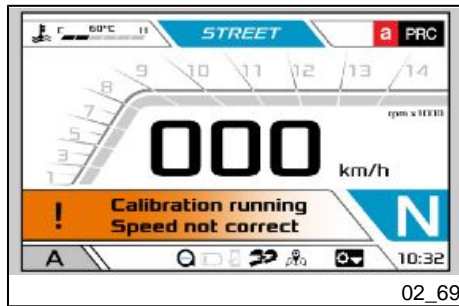

2.4) Calibration (Calibration)

When the Calibration function is selected (with the vehicle at a standstill), once calibration is activated by pressing MODE RIGHT briefly to the right, a screen appears with the following description at the bottom left of the display:

Calibration running Speed not correct

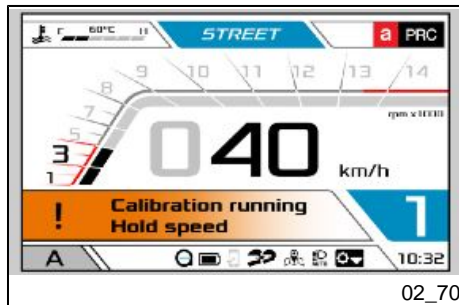

To calibrate the a-PRC system (Aprilia Performance Ride Control), ride the vehicle on a straight section of level road in the second gear at a speed of 40 +/- 2 km/h (24.85 +/- 1.24 mph) for about 10 seconds.

The message "Calibration running Hold speed" appears on the digital display.



If calibration is completed successfully, the message "Calibration done Key OFF Wait 60 seconds" is displayed.

NOTE

WHEN THE MESSAGE "Calibration done Key OFF wait 60 seconds" APPEARS ON THE DISPLAY, STOP THE VEHICLE AND TURN THE IGNITION TO KEY-OFF FOR AT LEAST 60 SECONDS TO COMPLETE THE CALIBRATION.

THIS ALLOWS THE CALIBRATION TO BE STORED IN THE MEMORY.

NOTE

THE CALIBRATION PROCEDURE IS USED TO OPTIMISE a-PRC FUNCTIONALITY IN THE EVENT OF CHANGING TYRE TYPE OR FINAL DRIVE RATIO (PINION-SPROCKET COMBINATION).

IF THE VEHICLE IS FITTED WITH TYRES OTHER THAN THOSE INDICATED IN THIS USE AND MAINTENANCE MANUAL, THE LEVEL SETTINGS OF THE SYSTEM MAY NEED TO BE MODIFIED IN ORDER TO OBTAIN THE SAME BEHAVIOUR AS BEFORE.

NOTE

TURN THE IGNITION SWITCH OFF TO ABORT THE CALIBRATION PROCEDURE.

DURING CALIBRATION, ATC IS AUTOMATICALLY DEACTIVATED (IF PREVIOUSLY ACTIVATED).

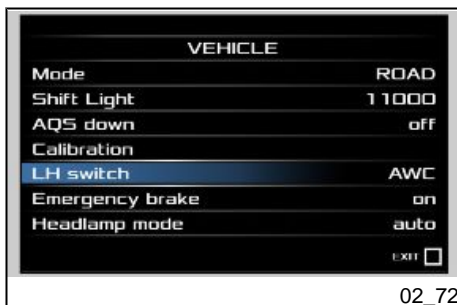
**2.5) LH Switch (left control) (only in the ROAD/NAVI mode)**

This function allows you to assign to the selector the "cruise control" or "AWC" function.

If the AWC is active assigned to the control on the left switch cluster, it will be possible to change the value of the AWC system while moving.

Select the LH switch item and briefly press on the MODE right button to select the desired function.

Press MODE SET briefly to go back to the main MENU.

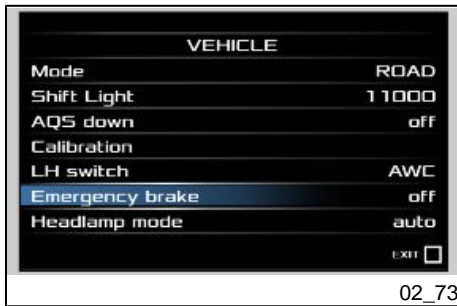

2.6) Emergency brake (brake light) (in ROAD/NAVI mode only)

When enabled, this function automatically activates the hazard warning lights in the event of hard and/or sudden braking. Activation of the hazard warning lights is not dependent on whether the ABS system is triggered.

Briefly press the MODE RIGHT button to activate the function if it is inactive and press it again to reactivate the function.

Press MODE SET briefly to go back to the main MENU.



2.7) PIT status (in RACE mode only)

This system allows you to control the system that limits the speed in the pit-lane (for example on a race track). The "PIT status" function may be enabled or disabled from this submenu.

Briefly press the MODE RIGHT button to activate the system if it is inactive. Further presses on the button will cyclically activate and deactivate the system.

Press MODE SET briefly to go back to the main MENU.

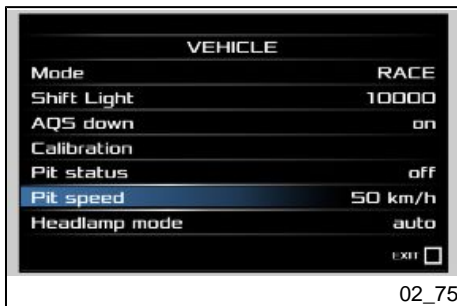

2.8) Pit speed (pit limiter speed) (in RACE mode only)

This function may be used to modify the speed limit when the "PIT limiter" function is active.

Press MODE RIGHT briefly to highlight the function in red, and then press MODE UP or MODE DOWN briefly to increase or decrease the speed setting.

Press MODE RIGHT again to confirm the selection. Once confirmed, the newly selected setting is highlighted in green.

Press MODE SET briefly to go back to the main MENU.

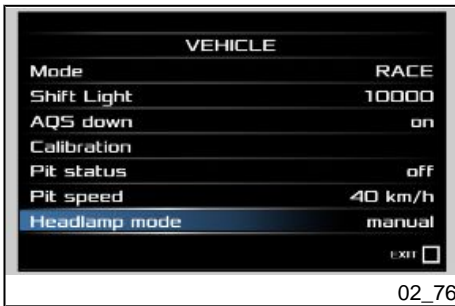

2.9) Headlamp mode

This function is used to set the operating mode of the lights.

Briefly press on the MODE RIGHT button to select the use mode. These modes will be visible cyclically every time the button is pressed.

Auto = Automatic

Manual = Manual

Emergency = Emergency; (emergency mode must only be used in the event of a malfunction of the headlamp; and enables usage of the low beam headlights and DRL lights only)

Press MODE SET briefly to go back to the main MENU.

NOTE

THE RELATIVE ICON IS SHOWN ON THE DIGITAL DISPLAY WHEN "AUTO" MODE IS ACTIVE.

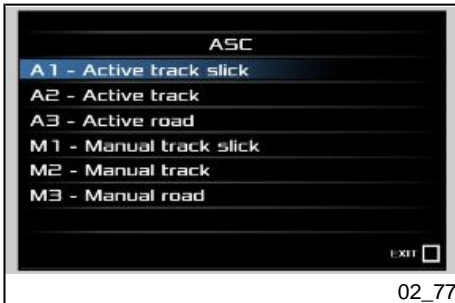

3) ASC (only for version with Ohlins - ASC suspensions)

The "ASC" menu is composed of the following entries:

- 3.1) A1 - Active track slick
- 3.2) A2 - Active track
- 3.3) A3 - Active road
- 3.4) M1 - Manual track slick
- 3.5) M2 - Manual track
- 3.6) M3 - Manual road

The functions of the "ASC" menu are shown in the paragraphs below.

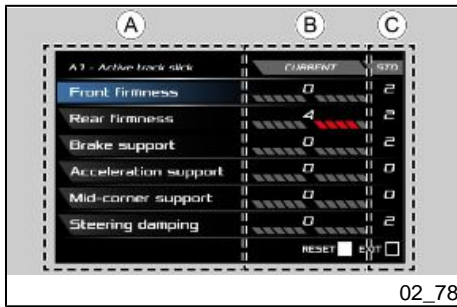

3.1) A1 - Active track slick / 3.2) A2 - Active track / 3.3) A3 - Active road

The automatic modes actively adapt the settings based on the vehicle's behaviour in relation with the driving style. More or less editable settings may be visible depending on the mode selected. The screen displayed will contain the following information:

- A) Type of parameter;
- B) Setting set by the user;
- C) Standard reference setting.

The parameters that can be edited in these two modes are:

- Front firmness (front damping)
- Rear firmness (rear damping)
- Brake support
- Acceleration support
- Mid-corner support
- Steering damping (Steering damper)

Press the MODE RIGHT button briefly to modify the parameter, increasing it by one point.

By pressing and holding the MODE RIGHT button, the increase will be continuous until the button is released.

Once the maximum setting value of the parameter being modified is reached, the count restarts from the lowest negative value.

By pressing and holding the MODE SET button, the selected parameter will be reset to the standard reference value.

The values can be modified from minimum -5 to maximum +5.

Briefly push the MODE SET button to return to the "ASC" menu.

NOTE

THE NUMBERS SET AT A LOW VALUE CORRESPOND TO A LOWER CONTROL AND THUS ARE IDEAL FOR A MORE SPORTIVE DRIVING.

THE NUMBERS SET AT A HIGH VALUE CORRESPOND TO A HIGHER CONTROL AND THUS ARE IDEAL FOR A MORE TOURISTIC DRIVING.

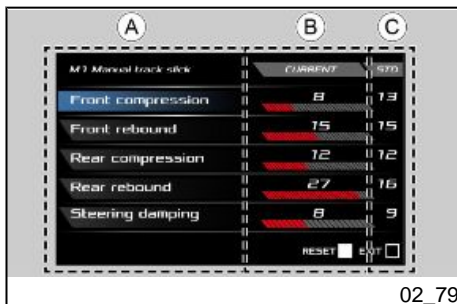
**3.4) M1 - Manual track slick / 3.5) M2 - Manual track / 3.6) M3 - Manual road**

These menus allow modifying the suspension settings in "manual" modes, by operating electronically on the mechanical settings. In each mode, the reference standard values are preset. More or less editable settings may be visible depending on the mode selected. The screen displayed will contain the following information:

- A) Type of parameter;
- B) Setting set by the user;
- C) Standard reference setting.

The parameters that can be edited in these two modes are:

- Front compression
- Front extension
- Rear compression
- Rear extension
- Steering damping (Steering damper)

Press the MODE RIGHT button briefly to modify the parameter, increasing it by one point.

By pressing and holding the MODE RIGHT button, the increase will be continuous until the button is released.

Once the maximum setting value of the parameter being modified is reached, the count restarts from the lowest negative value.

By pressing and holding the MODE SET button, the selected parameter will be reset to the standard reference value.

The "compression/extension" parameters can be modified from minimum 1 to maximum 31 (the value corresponds to one click of a traditional suspension)

The "steering damper" values can be modified from minimum 1 to maximum 21 (the indicated value corresponds to one click of a traditional steering damper)

Briefly push the MODE SET button to the left to return to the "ASC" menu.

NOTE

THE NUMBERS SET AT A LOW VALUE CORRESPOND TO A LOWER CONTROL AND THUS ARE IDEAL FOR A MORE SPORTIVE DRIVING.

THE NUMBERS SET AT A HIGH VALUE CORRESPOND TO A HIGHER CONTROL AND THUS ARE IDEAL FOR A MORE TOURISTIC DRIVING.

From the ROAD or RACE main screen showing the "T2" tab parameters, the **active** electronic suspension setting adjustment page can be directly accessed by briefly pressing the MODE SET button.

Briefly press the MODE SET button to return to the main screen.



4) Display

The "Display" menu contains the following options:

- 4.1) Backlight (Backlight)
- 4.2) Mode

The functions available in the "Display" menu are described in the following paragraphs.



4.1) Backlight (Backlight)

This function allows you to change the backlight of the digital display, from a minimum value of 1 to a maximum value of 10.

With each brief press on the MODE RIGHT button the back light intensity can be increased by one point. Once the maximum level is reached, any further press will restart the setting from the minimum value.

Press and hold the MODE RIGHT button to continuously increase the value until the button is released.

Press MODE RIGHT again to confirm the selection. Once confirmed, the newly selected setting is highlighted in green.

Press MODE SET briefly to go back to the main MENU.

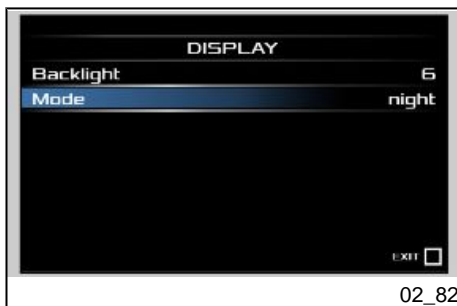

4.2) Mode

This function allows you to change the display mode of the digital display:

- AUTO (Automatic)
- DAY (Day)
- NIGHT (Night)

Briefly press on the MODE RIGHT button to select the use mode. These modes will be visible cyclically every time the button is pressed.

Press MODE SET briefly to go back to the main MENU.

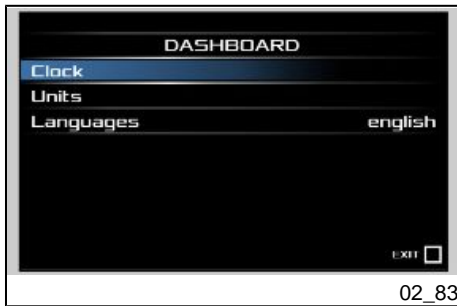

5) Dashboard (Dashboard)

The "Dashboard" menu contains the following options:

- 5.1) Clock (Clock)
- 5.2) Units (Units)
- 5.3) Languages (Languages)

The functions available in the "Dashboard" menu are described in the following paragraphs.



5.1) Clock (Clock)

The "Clock" menu contains the following options:

- 5.1.1) Set time (Set time)
- 5.1.2) 12H or 24H mode (12 H or 24 H display)

The functions available in the "Clock" menu are described in the following paragraphs.

Press MODE SET briefly to go back to the "Dashboard" menu.



5.1.1) Set time (Set time)

This menu allows you to set the clock and is divided in turn into the following entries:

- Hours
- Minutes

The value is increased by one point every time the MODE RIGHT button is briefly pressed. Once the maximum level is reached, any further press with restart the setting from the minimum value.

Press and hold the MODE RIGHT button to continuously increase the value until the button is released.

Press MODE SET briefly to go back to the "Clock" menu.

5.1.2) 12H or 24H mode (12 H or 24 H display)

To change the clock display format, briefly press the MODE RIGHT button.

Press MODE SET briefly to go back to the "Dashboard" menu.



02_86

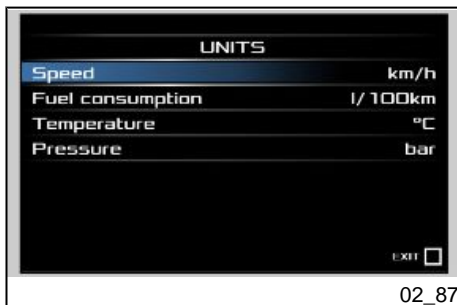

02_87

5.2) Units (Units)

This menu allows you to change the settings for displaying the units and is divided as follows:

5.2.1) Speed (Speed)

5.2.2) Fuel consumption (Fuel consumption)

5.2.3) Temperature (Temperature)

5.2.4) Pressure (where applicable)

Press MODE SET briefly to go back to the "Dashboard" menu.

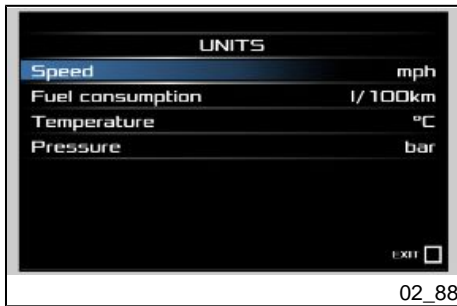

5.2.1) Speed (Speed)

This function may be used to change the unit of measurement used for speed.

Briefly press on the MODE RIGHT button to change the measurement unit.

Press MODE SET briefly to go back to the "Dashboard" menu.

NOTE

IF THE UNIT OF MEASURE SET AT THE FACTORY HAS BEEN CHANGED, THE SPEED'S UNIT OF MEASURE WILL FLASH FOR 30 SECONDS EACH TIME THE KEY IS ENGAGED.

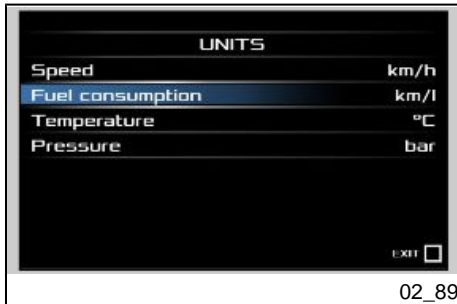

5.2.2) Fuel consumption (Fuel consumption)

This function is used to change the unit of measurement used for the fuel consumption:

- km/l
- l/100 km
- mpg (UK)
- mpg (USA)

Briefly press on the MODE RIGHT button to select the measurement unit. These units will be visible cyclically every time the button is pressed.

Press MODE SET briefly to go back to the "Dashboard" menu.

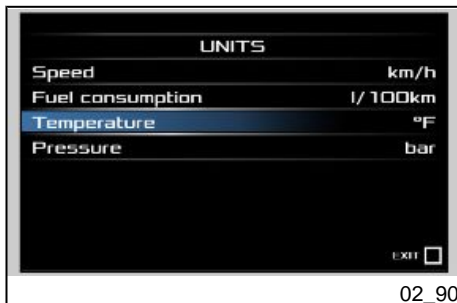

5.2.3) Temperature (Temperature)

This function is used to change the unit of measurement used for temperature:

- °C (Celsius degrees)
- °F (Fahrenheit degrees)

Briefly press on the MODE RIGHT button to change the measurement unit.

Press MODE SET briefly to go back to the "Dashboard" menu.

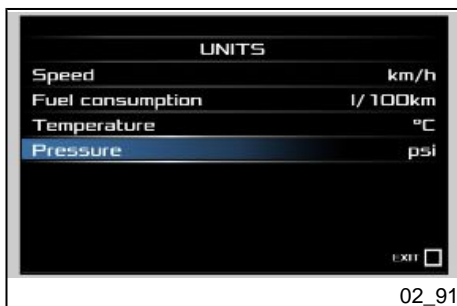

5.2.4) Pressure (where applicable)

This function is used to change the unit of measurement used for tyre pressure:

- bar;
- psi.

Briefly press on the MODE RIGHT button to change the measurement unit.

Press MODE SET briefly to go back to the "Dashboard" menu.

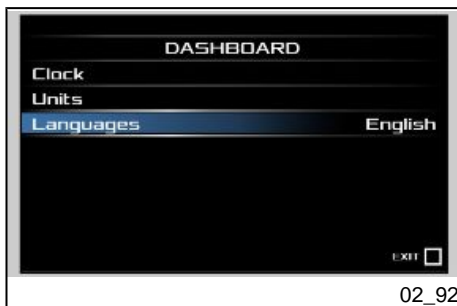

5.3) Languages (Languages)

This function is used to change the instrument panel display language:

- English
- Italian
- Francais (French)
- Deutsch (German)
- Espagnol (Spanish)

Briefly press on the MODE RIGHT button to select the next language. These languages will be visible cyclically every time the button is pressed.

Press MODE SET briefly to go back to the "Dashboard" menu.

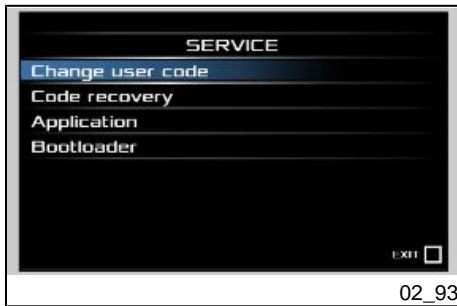

02_93

6) Service (Service)

The "Service" menu contains the following options:

- 6.1) Change user code (Change user code)
- 6.2) Code recovery (Code recovery)
- 6.3) Application
- 6.4) Boot loader

The functions available in the "Service" menu are described in the following paragraphs.

Press MODE SET briefly to go back to the main MENU.

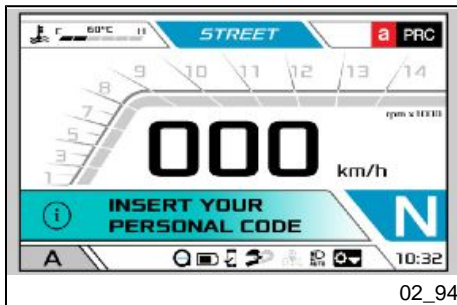

02_94

6.1) Change user code (Change user code)

This function may be used to modify the existing code (you must be in possession of the code itself in order to do this). The user code enables engine start even in the event of an immobiliser system fault. On a new vehicle, the user code is set by default as five zeros (00000) and the message "INSERT YOUR PERSONAL CODE" appears on the display for ten seconds when the ignition is switched on.

This function allows you to change the code itself and remove this message.

A value (from 0 to 9) is shown for the first figure of the code (furthest to left) on the display. Press MODE UP or MODE DOWN to modify the value. Press MODE SET briefly to confirm the selection. Repeat the operation for all the digits. Once the code is confirmed, the new code is shown steadily on the display to let the user verify that the code has been entered correctly. Turn the ignition off and then on again to unlock the dashboard. The last code set may be modified again in future. Access the setting mode again, enter the last user code used (OLD CODE), then enter a new user code (NEW CODE) as described previously.

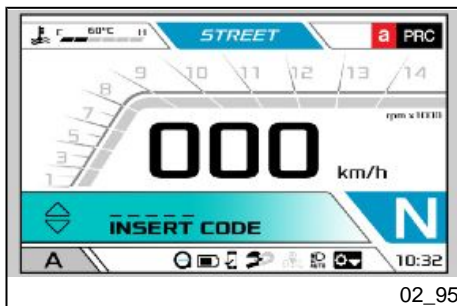

02_95

6.2) Code recovery (Code recovery)

This function must be used should it be necessary to change the user code when the user no longer remembers the current code. Both keys stored in the vehicle memory are needed to access this function.

Once the function is activated, pressing the MODE SET briefly displays the message "INSERT KEY 1", requesting identification of the first key. Insert the key. If the correct key is recognised within twenty seconds, the message "INSERT KEY 2" is shown on the display. Insert the second key. If the second key is also recognised within twenty seconds, the dashboard resets the user code to the default code (five zeros - 00000). Enter the new user code following the "CHANGE USER CODE " procedure.

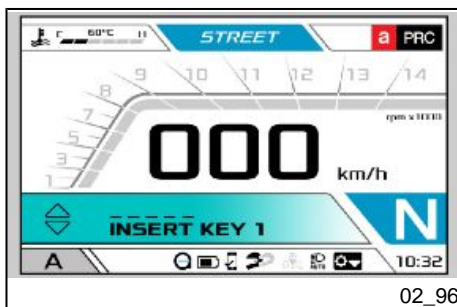

02_96

GPS NAVIGATION (where applicable)

The "APRILIA MIA" system, paired with the "APRILIA" application, allows GPS indications to be shown on the digital display. By means of pictograms, distance and travel time data, the desired destination can be reached.

Consult the navigation guide by accessing the "APRILIA" application with your account. The navigation icon appears on the digital display after setting the destination address.

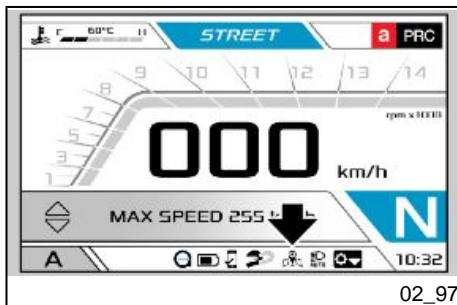

02_97

Press and hold down MODE UP to access the GPS navigation directions and information screen.

NOTE

BY SETTING THE DESTINATION ADDRESS THROUGH THE "APRILIA" APPLICATION, THE DIGITAL DISPLAY AUTOMATICALLY DISPLAYS THE DIRECTIONS SCREEN.

NOTE

"SHORT PRESS": PRESS THE BUTTON AND RELEASE WITHIN 0.5 SECONDS;

"PRESS AND HOLD": PRESS THE BUTTON AND HOLD FOR AT LEAST 2 SECONDS.

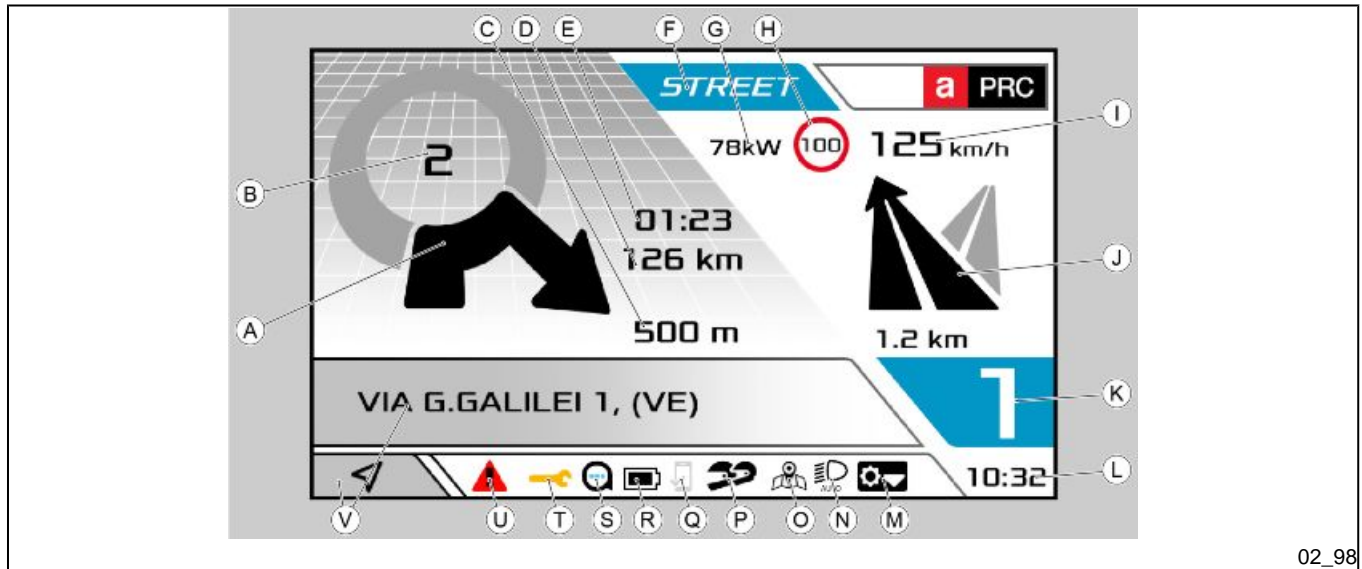

Navigation screen key:

A = next manoeuvre symbol;

B = number of exit to take from roundabout;

C = distance remaining to manoeuvre "A";

D = distance remaining to arrival at destination;

E = time remaining to arrival at destination;

F = selected/active riding mode;

G = Indication of the reduced power map presence;

H = speed limit applicable on current road;

I = speed (speedometer) (viewable in km/h or mph);

J = symbol of manoeuvre after next manoeuvre, and relative distance;

K = gear selected (displayed only with engine running and vehicle moving);

L = clock (time viewable in 24 or 12 hour format, without AM / PM indication);

M = downshift function state;

N = automatic lights mode enabled;

O = GPS/Navigator (if active);

P = rider/passenger intercom;

Q = Audio link with smartphone used to make calls, use voice commands and play music;

R = smartphone battery level;

S = data link with smartphone;

T = Maintenance icon

U = general warning icon

V = Trip computer log (TRIP A / TRIP B), phone, music, media player, system settings information a-PRC "T1" (ATC / AWC) or "T2" (ATC or ASC (where required) / AEM / AEB / ABS / ALC).

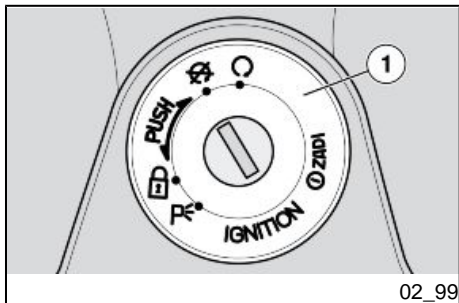

Ignition switch (02_99)

The ignition switch (1) is located on the upper plate of the headstock.

The vehicle is supplied with two keys (one is the spare key).

The lights can only be switched off with the ignition switch turned to "OFF".

NOTE

THE KEY IS USED IN THE IGNITION/STEERING LOCK SWITCH, THE KEYHOLE FOR THE FUEL TANK CAP, AND FOR THE SADDLE COMPARTMENT.

NOTE

THE LOW BEAM LIGHTS COME ON AUTOMATICALLY AFTER THE ENGINE STARTS.

NOTE

KEEP THE SPARE KEY IN DIFFERENT PLACE, NOT WITH THE VEHICLE.

LOCK: The steering is locked. It is not possible to start the engine or switch on the lights. The key can be extracted

OFF: The engine and lights cannot be set to work. The key can be extracted.

ON: The engine can be started. The key cannot be removed

PARKING: The steering is blocked. The engine cannot be started. The daylight running lights of the front and rear headlamps are activated. The ignition key can be extracted. Once the key has been extracted, the immobilizer system is active (if present).



02_100

Locking the steering wheel (02_100)

To lock the steering:

- Turn the handlebar fully to the left.
- Turn the ignition switch to "OFF".
- Push the key in and turn it anticlockwise (to the left), and steer the handlebar slowly until the key engages in the "LOCK" position.
- Extract the key.

CAUTION



TO PREVENT THE LOSS OF CONTROL OF THE VEHICLE, NEVER SET THE KEY ON ITS "LOCK" POSITION WHILE RUNNING.

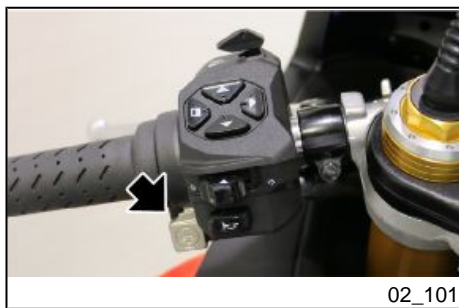

02_101

a-PRC setting buttons (02_101, 02_102)

Allow the adjustment of some functions of the a-PRC system, in particular of the ATC and ALC system.

From the main **ROAD** or **RACE** screen:

- By displaying the T1 parameters and using the "+" or "-" buttons it is possible to increase or decrease the control level of the ATC system.

- By displaying the T2 parameters and using the "+" or "-" buttons:

- If the motorcycle is not equipped with electronic suspension, managed by the ASC connection, the modification of the ATC level will be visible in this screen.
- If the motorcycle is equipped with electronic suspensions, managed by the ASC connection, the screen will change to the "T1" display highlighting the modified ATC control level.

- From all other trip computer views, if the ATC control level is changed, the instrument panel will automatically switch to the "T1" display.

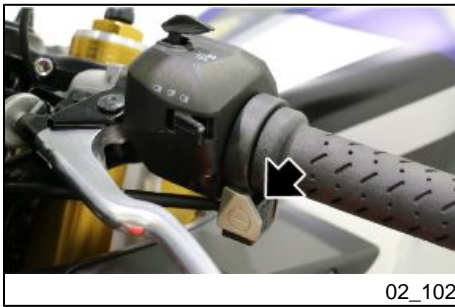

From the **NAVI** screen:

- From all trip computer views, if the ATC control level is changed, the instrument panel will automatically switch to the "T1" display.

To start the ALC system at the level previously selected in the menu, it is necessary to simultaneously press, at zero speed, the "+" and "-" buttons for more than three seconds, until the message "LAUNCH" appears on the digital display.

For further function details see paragraph "A-PRC SYSTEM"



Horn button (02_103)

Press it to activate the horn.



02_104

Switch direction indicators (02_104, 02_105)

Move the switch to the left to indicate a left turn; move the switch to the right to indicate a right turn. Pressing the switch deactivates the turn indicator.

CAUTION

IF THE TURN SIGNAL INDICATOR LAMP FLASHES RAPIDLY, THIS MEANS THAN ONE OR BOTH OF THE TURN SIGNAL LED MODULES HAVE FAILED.

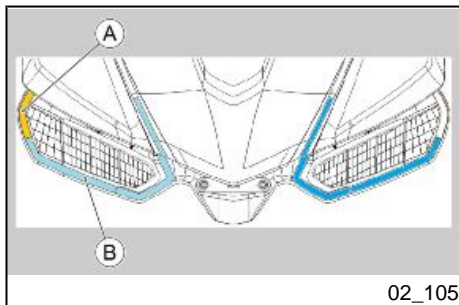

02_105

In DRL ON mode, the DRL light on the relative side (left or right) is dimmed automatically when a turn signal is activated (see figure).

The turn indicators have a self-cancelling function that implements the following logic.

With the vehicle at standstill (speed = zero), the turn indicators continue flashing indefinitely.

With the vehicle in motion, the turn signals self-cancel when one the two following conditions is met:

- After a time (t) = 40 sec.
- After riding 500 m (0.31 mi)

If the vehicle speed reaches zero during this period, the time and distance counts are reset and start again from zero when the vehicle starts moving once again.

Switching on the opposite side turn indicators without pressing the switch in the intermediate reset position causes both the time and distance counters to reset and recommence from zero.

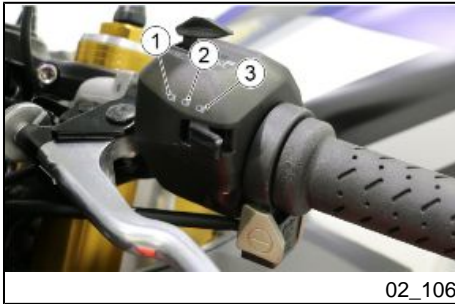

High/low beam selector (02_106)

In DRL ON mode:

- the DRL lights only are lit when the selector is left in the centre position (2).
- pressing the selector into position (1) switches on the high beam headlight
- press the selector into position (3) to flash the high beam headlamp to signal danger or an emergency.

When the low beam headlights are on (DRL OFF):

- the low beam lights only are lit when the selector is left in the centre position (2).
- pressing the selector into position (1) switches on the high beam headlight
- press the selector into position (3) to flash the high beam headlamp to signal danger or an emergency.



Passing button (02_107)

Press button (3) to flash the high beam headlamp to signal danger or an emergency.

Releasing the switch deactivates the high beam flash.



02_108

Daytime/night lights switch (02_108, 02_109)

This button selects the operating mode of the daytime running lights (DRL) or low beam headlights.

- Press the button briefly to cycle through the modes available.

NOTE

IF THE "HEADLAMP MODE" FUNCTION (SEE PARAGRAPH "ADVANCED FUNCTIONS") IS SET TO "AUTO" (AUTOMATIC), THE TWILIGHT SENSOR IS ALSO USED TO SWITCH THE LOW BEAM HEADLIGHTS ON AUTOMATICALLY IN LOW LIGHT CONDITIONS.

IF THE "HEADLAMP MODE" FUNCTION IS SET TO "EMERGENCY", THE DAY-TIME RUNNING LIGHTS (DRL) ARE DISABLED AND THE LOW BEAM HEADLIGHTS ONLY REMAIN PERMANENTLY LIT.

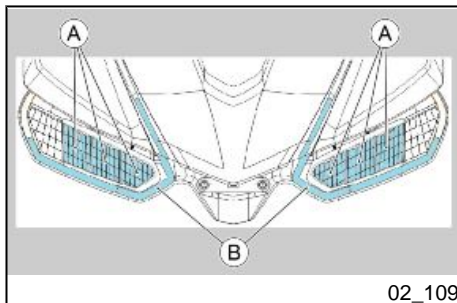

02_109

NOTE

WHEN THE LOW BEAM HEADLIGHTS ARE ON (A), THE BRIGHTNESS OF THE DRL LIGHTS (B) IS DIMMED.



Start-up button (02_110)

Press the button on the right hand handlebar control set to turn the engine over with the starter motor.

The following conditions are necessary to permit engine start:

- If the vehicle is in neutral with the side stand extended: apply the front or rear brake and simultaneously press the starter button on the right hand handlebar control set.
- If any gear is engaged: pull the clutch lever, apply the front or rear brake and simultaneously press the starter button on the right hand handlebar control set.

Engine stop switch (02_111)

CAUTION



DO NOT OPERATE THE ENGINE STOP SWITCH WHILE RIDING THE VEHICLE.



It acts as a safety or emergency switch.

Press and hold the ignition switch in the "KEY ON" position to start the engine; press the switch to set it to "KEY OFF" to stop the engine.

NOTE

WITH ENGINE OFF AND THE IGNITION SWITCH SET TO «ON» THE BATTERY MAY DISCHARGE.

Selector Cruise Control / AWC (02_112, 02_113, 02_114, 02_115)**CAUTION**

CRUISE CONTROL IS ONLY AVAILABLE IN ROAD AND NAVI MODES

CAUTION

ALWAYS SWITCH OFF THE SYSTEM (SWITCHING FROM ON TO OFF) BEFORE CHANGING THE RIDING MODE.

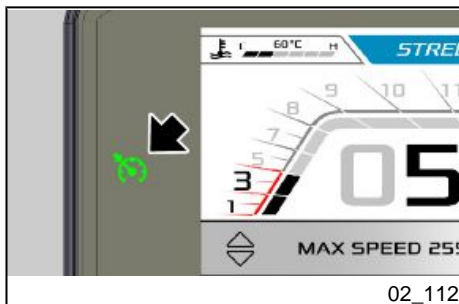

Cruise control is an electronic system that keeps the vehicle at a constant speed selected by the rider.

Push and hold (more than 1 second) the cruise control selector to the left switch the system on (OFF -> ON). The relative indicator on the dashboard instrument panel flashes to confirm that the system is on.

Going from OFF to ON is also possible with the engine off, as long as the engine stop switch is on RUN.

NOTE

IF THERE IS AN ANTI-THEFT SYSTEM, IT SHOULD BE UNLOCKED TO ALLOW THE SYSTEM TO BE ACTIVATED.



02_113

The system can be used in certain ranges of speeds for the gears from the third to the sixth, even during deceleration and with the throttle grip released.

The maximum and minimum settable speed values depend on the gear currently selected

Once at the required speed, the cruise control system may be activated by the rider (switched to SET state) by pushing the cruise control selector briefly (for less than 1 second) to the left, provided that the following conditions are met:

- The engaged gear cannot be less than the third and even in neutral;
- The brakes should not be operated;
- The clutch must not be operated;
- The speed conforms to the limit established for each gear

The indicator lamp on the instrument cluster lights continuously to indicate that the system is active.

The rider may now release the throttle grip, as the system will automatically maintain the set speed.

It is possible to increase or decrease the cruising speed by a short press (less than 1 second) of the cruise control switch up or down (increase / decrease the speed of 2 km/h (1.24 mph)) or via a long press (from 1 to 20 seconds) up or down (increase / decrease in the constant speed). The throttle may be used to increase speed temporarily by up to 30 km / h (18.64 mph) for the third, fourth and fifth gear and 40 km / h (24.85 mph) for the sixth gear with respect to the selected speed without turning off the system (e.g. passing). If the increase in speed exceeds 30 km/h (18.64 mph) for the third, fourth and fifth gear and 40 km/h (24.85 mph) for the sixth gear, it will cause a system deactivation (change from SET to ON, flashing light). Released the throttle grip, the motorcycle will return to the selected cruising speed.

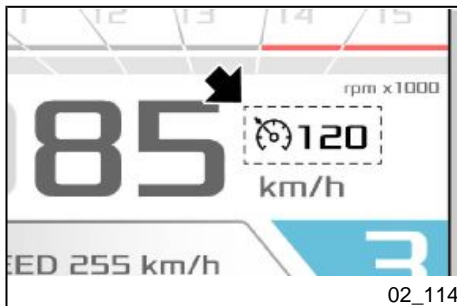
**NOTE**

THE SYSTEM WILL DEACTIVATE IF DURING ACCELERATION THE SPEED EXCEEDS THE MAXIMUM PERMISSIBLE SPEED FOR THE GEAR IN WHICH THE SYSTEM WAS ACTIVE.

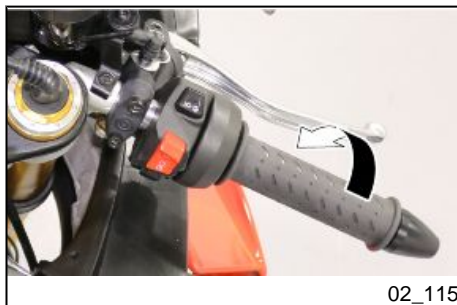

The system is deactivated (change from SET to ON status) if any of the following conditions:

- By operating the clutch;
- Operating the front/rear brake;
- Inserting a lower gear than 3rd or shift into neutral;
- By briefly moving the selector to the left;
- If the engine rpm limiter is activated;
- If the tracking control is activated;
- If climbs or particularly steep descents appear;
- Turning the throttle grip in the direction of contrary rotation

The system can be activated any time observing as usual the previously described conditions and keeping the selector pressed upward (for more than 1 second) if you want to reconfirm the last cruise speed used or by briefly moving the selector to the left to set a new cruising speed.

The system turns off completely (change from SET to the OFF state), then the stored speed is lost and the instrument cluster light goes off, if any of the following conditions are present:

- Keeping the cruise control selector moved to the left (for more than 1 second);
- Run-off interrupter activated;
- Engine stop (Key-OFF);
- Failure, malfunction of a component involved in controlling the speed (tone wheels sensors, control units, etc.)

CAUTION

WHEN ENTERING THE ADJUSTMENT MODE OF THE CRUISE CONTROL, THE QUICK SHIFT SYSTEM IS DISABLED.

AWC SELECTOR (Aprilia Wheelie Control)

(when enabled from the menu)

Once the AWC function has been activated by the menu settings and therefore can be interacted with, using the selector switch it is possible to change the intervention value with a short shift up or down.

Each modification of the intervention level switches the digital display to the "T1" information view.

The AWC function can be disabled from level 1 with a short shift downwards of the MODE selector.

**Button PIT (02_116, 02_117)**

This button activates the PIT LANE function (in RACE mode only), which limits the speed of the vehicle in a predetermined geographical area, such as the pit lane on a race track.

Once the function has been activated from the relative menu (see chapter "ADVANCED FUNCTIONS"), pushing the PIT selector briefly to the left activates the function, and the chequered flag symbol appears on the digital display to confirm that the function is active.

To deactivate the PIT LANE function, press the PIT button again briefly to the left or change gear.

The PIT speed limiter function may be set within a speed range from 30 to 90 km/h (19 to 56 mph)

**CAUTION**

THE PIT LANE FUNCTION CAN ONLY BE ACTIVATED WITH THE VEHICLE IN FIRST GEAR.

CAUTION

WHEN THE SYSTEM IS ACTIVE, THE IMMOBILIZER INDICATOR LIGHT FLASHES.

System a-PRC (Aprilia Performance Ride Control) (02_118, 02_119, 02_120)

Aprilia Performance Ride Control is an integrated electronic control system that helps improving the performance and the driver's safety.

a-PRC consists of 9 systems:

ALC: Aprilia Launch Control;

AEM: Aprilia Engine Map;

AEB: Aprilia Engine Brake;

ASC: Aprilia Suspension Control (if available);

ABS: Anti-locking system;

ATC: Aprilia Traction Control;

AWC: Aprilia Wheelie Control;

AQS: Aprilia Quick Shift;

PIT: Pit Control.

Aprilia Launch Control

Launch control: a system designed to help the rider optimise acceleration during standing starts. Its level can be changed from 1 (minimum intervention) to 3 (maximum intervention)

CAUTION

THE ALC SYSTEM MUST BE USED WITH EXTREME PRUDENCE AS THERE IS NO FUNCTION TO PREVENT THE MOTORCYCLE FROM TIPPING OVER IN ANY OF THE THREE POSSIBLE SETTING LEVELS.

THE SYSTEM IS FOR EXPERT RIDERS AND EXCLUSIVELY FOR TRACK USE.

RELEASE THE CLUTCH PROGRESSIVELY TO PREVENT EXCESS SLIPPAGE, WHICH COULD DAMAGE THE MECHANICALS OF THE VEHICLE.

CAUTION

TO GAIN FAMILIARITY WITH THE ABS SYSTEM, WE RECOMMEND USING LEVEL "3" TO START WITH. AND THEN, ONCE YOU FEEL COMFORTABLE WITH THE SYSTEMS, TRY THE OTHER LEVELS TO IDENTIFY WHICH ARE THE BEST SUITED TO YOUR RIDING STYLE AND FOR DIFFERENT ROAD AND WEATHER CONDITIONS.

LEVEL "1" IS RECOMMENDED FOR EXPERT RIDERS IN IDEAL ROAD SURFACE CONDITIONS.

LEVEL "2" IS AN INTERMEDIATE SETTING BETWEEN LEVEL "1" AND LEVEL "3".

THE HIGHER THE INTERVENTION LEVEL, THE HIGHER THE ENGINE RPM WILL BE TO WHICH THE LIMITATION IS APPLIED.

CAUTION



AVOID REPEATING THE LAUNCH SEVERAL CONSECUTIVE TIMES WITHOUT COOLING THE CLUTCH FIRST.

ALC, controlled launch, is a specific traction control use system that takes into consideration the initial speed as zero. Once the LAUNCH control function is activated and the throttle is opened completely, the engine speed increases to and is maintained at approximately 10,000 rpm, irrespective of the level set. The LAUNCH function is automatically deactivated in the event of any of the three following situations:

- A gear higher than second is selected.
- Vehicle speed exceeds the preset speed limit of 160 Km/h (99 mph).
- The throttle grip is closed.

To start the ALC system at the level previously selected in the menu, it is necessary to simultaneously press, at zero speed, the keys "+" and "-" for more than 3 seconds, until the "LAUNCH" message appears on the digital display.

When ALC is activated, the ATC and AWC systems are automatically deactivated and remain so until the ALC function is exited ALC (message cleared from digital display). Once the ALC function is exited, the ATC and AWC systems resume operation with the settings selected previously.

To reach the a-PRC system adjustment screen and change the ALC system intervention level, keep the "riding mode/a-PRC" button on the right light switch pressed.

The system intervention level depends on the selected riding mode.

CAUTION

DURING THE INITIAL STAGE OF ALC FUNCTION (DURING CLUTCH RELEASE), THE SYSTEM HELPS THE RIDER KEEP THE FRONT WHEEL AS CLOSE TO THE GROUND AS POSSIBLE.

DURING THE SECOND STAGE OF ALC FUNCTION (WITH THE CLUTCH LEVER COMPLETELY RELEASED), THE OBJECTIVE OF THE SYSTEM IS TO HELP THE RIDER MAXIMISE VEHICLE ACCELERATION IN RELATION TO THE ALC LEVEL SELECTED. DURING THE SECOND STAGE OF OPERATION, THE SYSTEM ALLOWS THE FRONT WHEEL TO LIFT FROM THE GROUND TO MAXIMISE ACCELERATION.

AWC and/or **ALC** can only be activated if the **ATC** system is on. This means that neither the wheelie control function nor launch control can be selected unless the

traction control is on. The three systems can therefore be set independently of one another and can function simultaneously.

AEB

Aprilia Engine Brake is a system which manages the engine brake, with three selectable levels:

- Level 1 has the least invasive engine brake.
- Level 2 has an intermediate level.
- Level 3 has the most invasive engine brake.

The effects are perceived at medium and high rpm values.

AEM

Aprilia Engine Map is a system controlling power delivery maps:

- Level 1, suitable for performance use causes high fuel consumption.
- Level 2 is recommended for on-road use in good grip conditions.
- Level 3 is recommended for road use in poor grip / wet conditions. The vehicle is easier to manage.

Aprilia Suspension Control (if available)

This vehicle is equipped with an ÖHLINS Smart EC 2.0. system.

The system is composed of front suspension, rear suspension, steering damper and control unit (Suspension Control Unit).

ASC provides preset damping levels, optimized for various conditions, for front and rear suspensions.

Through the control unit that receives signals from the various control units of the vehicle, the front and rear suspensions are constantly updated with the driving conditions.

This results in an optimized compression and extension damping, based on the vehicle's behaviour during driving. The system permanently adjusts the compression and extension damping levels according to the circumstances.

The ASC system also controls the steering damper, whose function is to dampen the rotation of the handlebar.

ASC operates electronically on the hydraulic brake of the steering damper, according to the setting.

The spring pre-load of the front and rear suspension can be manually adjusted.



PAY SPECIFIC ATTENTION WHEN DISCONNECTING THE CONNECTORS, TO AVOID DAMAGING THEM, WHICH WOULD COMPROMISE THE OPERATION OF THE VEHICLE.

There are two modes: Automatic and Manual:

- **A1 - Active track slick** Mode specific to closed tracks, racetrack use.
- **A2 - Active track** Mode specific for sportive road use.
- **A3 - Active road** Mode specific for more comfortable road use.
- **M1 - Manual track slick** Mode specific to closed tracks, racetrack use.
- **M2 - Manual track** Mode specific for sportive road use.
- **M3 - Manual road** Mode specific for more comfortable road use.

For each mode, the control type of the ASC system can be modified.

Depending on the selected mode, the following parameters can be modified:

- **Front firmness (front damping):**Control that allows balancing the front suspension between comfort and stability. An adjustment aimed at comfort improves the filtering of the road bumps and the shock absorption; vice versa, an adjustment aimed at stability, increases the dampening of the movements.

- **Front compression:** Energy absorption control when the front suspension is compressed. Therefore, the compression is adjusted when the front wheel is subjected to a load.
- **Front extension:** Energy absorption control when the front suspension is in extension phase. It adjusts the speed with which the suspension returns to the normal position after having been compressed.
- **Rear firmness (rear damping):** Control that allows balancing the rear suspension between comfort and stability. An adjustment aimed at comfort improves the filtering of the road bumps and the shock absorption; vice versa, an adjustment aimed at stability, increases the dampening of the movements.
- **Rear compression:** Energy absorption control when the rear shock absorber is compressed. Therefore, the compression speed is adjusted when the rear wheel is subjected to a load.
- **Rear extension:** Energy absorption control when the rear suspension is in extension phase. It adjusts the speed with which the suspension returns to the normal position after having been compressed.
- **Brake support:** Energy absorption control when the vehicle is braking, based on the set resistance value, the load variation and consequently offering better control.

- **Acceleration support** Control that allows balancing the suspensions during the acceleration phases, limiting (depending on the set value) the load variation and consequently offering better control.
- **Mid-corner support:** Control that allows balancing the suspensions while cornering, limiting (based on the set value) the load variations and consequently offering better control.
- **Steering damper:**Steering dampening control.

FACTORY SETTINGS TABLE

Parameters	A1 - Active track slick	A2 - Active track	A3 Active road	M1 - Manual track slick	M2 - Manual track	M3 - Manual road
Front firmness	2	0	0	-	-	-
Front compression	-	-	-	13	23	28
Front extension	-	-	-	15	21	28
Rear firmness	2	0	0	-	-	-
Rear compression	-	-	-	12	20	25
Rear extension	-	-	-	16	16	28
Brake support	2	0	0	-	-	-
Acceleration support	0	0	-	-	-	-
Mid-corner support	0	0	-	-	-	-

Parameters	A1 - Active track slick	A2 - Active track	A3 Active road	M1 - Manual track slick	M2 - Manual track	M3 - Manual road
Steering damper	2	0	0	9	9	9

CAUTION

IN CASE OF AN ELECTRICAL ANOMALY OR IF A SUSPENSION CONNECTOR IS DISCONNECTED, THE CURRENTLY USED MODE INDICATOR LIGHT WILL FLASH, INDICATING A FAULT OF THE ASC SYSTEM. THEREFORE, DRIVE CAREFULLY AND IMMEDIATELY CONTACT AN OFFICIAL APRILIA DEALER.

CAUTION

EVEN IF A FAULT IS SIGNALLED AND THEREFORE WHEN THERE IS NO ELECTRONIC SUSPENSION MANAGEMENT, THEY WILL NOT LOSE THEIR TRADITIONAL MECHANICAL FUNCTIONALITY.

ABS

The ABS with CORNERING is a device to avoid the wheels locking in case of emergency braking also when cornering, thus increasing vehicle stability when braking when compared with a traditional braking system.

The CORNERING mode takes into account the motorcycle's lean angle, so as to maximise efficiency without endangering the rider.

The ABS system improves vehicle control provided that the physical limits of vehicle grip on the road are not exceeded. The rider is fully responsible for riding at a suitable speed based on weather and road conditions, always leaving an appropriate safety margin.

Under no circumstances can the ABS system compensate for the rider's misjudgment or improper use of brakes.

The ABS system may be set to three different levels from 1 (minimum slip control) to 3 (maximum slip control), from the specific setting screen (see paragraph in the "SELECTING MAPS").

Level 1 is suitable for performance use by expert riders only. At this level the lifting control of the rear wheel is not active and neither is the cornering system. ABS is effective on the front wheel only.

Level 2 is suitable for performance use in good grip conditions. Rear wheel lift control is active, but at a more performance-biased setting, allowing a certain degree of rear wheel lift in specific braking conditions

Level "3" is suitable for day-to-day usage in all conditions - e.g. on urban or extra-urban roads, in wet surface conditions. It does not allow, in most cases, for the lifting of the rear wheel.

CAUTION

BEFORE RIDING OFF, CHECK THE ABS LEVEL OF INTERVENTION SELECTED. SHUTTING DOWN THE VEHICLE RETURNS THE ABS SYSTEM'S FUNCTIONALITY TO THE LAST ABS LEVEL UTILISED.

NOTE

WHEN THE ABS STARTS WORKING, A PULSING IS FELT ON THE BRAKE LEVER.



THE ANTI-WHEEL LOCK SYSTEM DOES NOT PREVENT FALLS ON A BEND WHEN LEVEL "1" IS USED.

AN EMERGENCY BRAKING WITH THE VEHICLE INCLINED, HANDLEBAR TURNED, ON UNEVEN OR SLIPPERY ROADS, OR WITH POOR GRIP, CREATES A LACK OF STABILITY DIFFICULT TO HANDLE. RIDE CAREFULLY AND SENSIBLY AND ALWAYS BRAKE GRADUALLY.

DO NOT SPEED RECKLESSLY. THE VEHICLE GRIP ON THE ROAD IS SUBJECT TO LAWS OF PHYSICS WHICH NOT EVEN THE ABS SYSTEM CAN ELIMINATE.

When the vehicle is started, after the initial instrument panel check cycle, the ABS warning lamp flashes until the vehicle reaches a speed of 3.1 mph (5 km/h), after which it goes out.

If with the ABS activated (level 3, 2, 1) the ABS warning light turns on permanently, or continues to flash even when exceeding 5km/h (3.1 mph), a failure has been detected and the ABS has been deactivated.

In this case carry out the following operations:

- stop the vehicle;
- Key OFF-ON;
- ride the vehicle to a speed above 5 km/h (3.1 mph): the ABS warning light must be turned off;
- the ABS system is working.

If the ABS disabled indication remains:

NOTE

SHOULD THIS OCCUR, CONTACT AN Aprilia Approved Dealer.

NOTE



IN CASE OF EXTENDED REAR WHEEL ROTATION WITH THE FRONT ONE LOCKED (BURNOUT, MOTORCYCLE ON THE CENTRE STAND, ETC.) THE SYSTEM CAN BE DEACTIVATED AUTOMATICALLY WHEN THE ABS and a-PRC INDICATOR LIGHT STAYS ON.

TO REACTIVATE, TURN THE IGNITION SWITCH OFF AND THEN ON AGAIN AND SELECT THE REQUIRED SETTING.

NOTE

THE SAFETY PROVIDED BY THE ABS DOES NOT, IN ANY CASE, JUSTIFY RISKY MANOEUVRES. EVEN THOUGH THE ABS SYSTEM ENSURES GREATER VEHICLE CONTROL IN THE EVENT OF EMERGENCY BRAKING, ALWAYS OBSERVE THE CORRECT MINIMUM SAFETY DISTANCE FROM THE VEHICLE IN FRONT OF YOU.



THE ABS SYSTEM ACTS ON BOTH THE FRONT AND REAR WHEELS BY OBTAINING INFORMATION FROM THE ROTATION/ LOCKING TONE WHEELS. ALWAYS CHECK THAT THE TONE WHEEL IS CLEAN, AND REGULARLY CHECK THAT THE DISTANCE FROM THE SENSOR IS CONSTANT ON ALL 360 DEGREES. SHOULD THE WHEELS BE REMOVED AND REFITTED, IT IS VERY IMPORTANT TO CHECK THAT THE DISTANCE BETWEEN TONE WHEEL AND SENSOR IS THE ONE SPECIFIED. FOR CHECKING AND ADJUSTMENT, CONTACT AN Authorised Aprilia Workshop.



WHERE THE MOTORCYCLE HAS AN ABS SYSTEM, NON-APPROVED BRAKE PADS AND TYRES COMPROMISE SMOOTH BRAKING, DRASTICALLY REDUCING DRIVING SAFETY.

NOTE

THE SYSTEM'S SENSORS, HAVING A SIGNIFICANT ACCURACY OF READING THE TONE WHEELS, MAY GENERATE, A MOTORCYCLE STOPPED AND THE ENGINE RUNNING, INDICATION OF SPEED OF SOME km / h (mph) ON THE DIGITAL DISPLAY.

SUCH BEHAVIOUR IS TO BE CONSIDERED NORMAL AND DOES NOT CREATE MALFUNCTIONS IN THE SYSTEM.



IF THE GAP FOR ONE OR BOTH SENSORS IS NOT WITHIN THE TOLERANCE INDICATED BELOW, TAKE THE MOTORCYCLE TO AN Approved Aprilia Dealer

Characteristic

Distance between tone wheel and front sensor

0.5 - 2.00 mm (0.020 - 0.079 in)

Distance between tone wheel and rear sensor

0.5 - 2.00 mm (0.020 - 0.079 in)

Aprilia Traction Control

Traction control: a system designed to help the rider control wheelspin.

ATC is a system that monitors and, if necessary, limits rear wheelspin under acceleration to increase vehicle stability.

While ATC improves vehicle control, it does not allow the physical handling limits of the vehicle to be exceeded. The rider is fully responsible for riding at a suitable speed based on weather and road conditions, always leaving an appropriate safety margin.

Under no circumstances can ATC compensate for any rider error or improper use of the throttle.



THE TRACTION CONTROL SYSTEM CANNOT PREVENT FALLS WHILE CORNERING.

ACCELERATING SUDDENLY WHILE THE VEHICLE IS INCLINED OR WITH THE HANDLEBARS TURNED WILL PUT THE VEHICLE IN AN UNSTABLE STATE THAT IS EXTREMELY DIFFICULT TO RECTIFY.

DO NOT SPEED RECKLESSLY. LIMITS OF GRIP ARE DETERMINED BY LAWS OF PHYSICS WHICH EVEN THE ATC SYSTEM CANNOT OVERCOME.

The ATC system also responds optimally and limits wheelspin during cornering.

This is made possible by the inertia sensor platform, which provides the ECU with precise information concerning the inclination of the motorcycle.

ATC SYSTEM DEACTIVATED MANUALLY

At key-on and after the initial instrument panel check cycle, if the system is deactivated, the a-PRC indicator light remains lit constantly until the rider activates the system again.

ATC SYSTEM ACTIVE

At key-on and after the initial instrument panel check cycle, if the system was active at the last key-off, the a-PRC indicator light flashes until the vehicle exceeds 5 Km/h (3.1 mph), after which it extinguishes.

If the a-PRC indicator light remains constantly lit, this means that a fault has been detected and the ATC system has been automatically deactivated.

In this case carry out the following operations:

- stop the vehicle;

- Key OFF-ON;
- reactivate the system manually
- ride the vehicle to a speed above 5 km/h (3.1 mph): the a-PRC indicator light should extinguish;
- ATC system working correctly.

If the 'ATC system deactivated' indication persists:

NOTE

SHOULD THIS OCCUR, CONTACT AN Aprilia Approved Dealer.



THE ATC SYSTEM ACTS ON THE REAR WHEEL ON THE BASIS OF INFORMATION RECEIVED FROM TONE WHEELS INSTALLED ON BOTH WHEELS. ALWAYS CHECK THAT THE TONE WHEELS ARE CLEAN, AND REGULARLY CHECK THAT THE GAP BETWEEN THE TONE WHEEL AND THE SENSOR IS CONSTANT AROUND THE ENTIRE CIRCUMFERENCE OF THE TONE WHEEL ITSELF. SHOULD THE WHEELS BE REMOVED AND REFITTED, IT IS VERY IMPORTANT TO CHECK THAT THE DISTANCE BETWEEN TONE WHEEL AND SENSOR IS THE ONE SPECIFIED. FOR CHECKING AND ADJUSTMENT, CONTACT AN Authorised Aprilia Workshop.

NOTE

IN CASE OF EXTENDED REAR WHEEL ROTATION WITH THE FRONT ONE LOCKED (BURNOUT, MOTORCYCLE ON THE CENTRE STAND, ETC.) THE SYSTEM CAN BE DEACTIVATED AUTOMATICALLY WHEN THE a-PRC INDICATOR LIGHT STAYS ON.

TO REACTIVATE, TURN THE IGNITION SWITCH OFF AND THEN ON AGAIN AND SELECT THE REQUIRED SETTING.

NOTE

a-PRC SYSTEM SENSORS, WITH HIGH PRECISION OF READING THE TONE WHEELS, CAN GENERATE, WITH MOTORCYCLE AT STANDSTILL AND ENGINE RUNNING, A km/h (mi) SPEED INDICATION IN THE DIGITAL DISPLAY.

SUCH PERFORMANCE IS NORMAL AND DOES NOT CAUSE MALFUNCTIONING OF THE a-PRC SYSTEM.

Characteristic**Distance between tone wheel and front sensor**

0.5 - 2.00 mm (0.020 - 0.079 in)

Distance between tone wheel and rear sensor

0.5 - 2.00 mm (0.020 - 0.079 in)

The system is active by default. However, if the system has been deactivated, in order to reactivate it, the user must access the specific screen using the selector button on the right hand handlebar control set

Using the MODE navigation buttons, select level 1 if the level was set to 0.

When the ATC system is activated with the vehicle at a standstill, the a-PRC indicator light flashes until the vehicle reaches a speed of 5 Km/h (3.1 mph).

Press the MODE UP e MODE DOWN buttons briefly to increase or decrease the ATC level setting from "0" (minimum system intervention) to "8" (maximum system intervention).

NOTE

THIS IS ALSO POSSIBLE WITH THE MOTORCYCLE IN MOTION.

CAUTION

TO GAIN FAMILIARITY WITH THE ATC SYSTEM, PREFERABLY USE LEVEL "8" TO START WITH, THEN TRY THE OTHER LEVELS TO IDENTIFY WHICH ARE

THE BEST SUITED TO YOUR RIDING STYLE AND FOR DIFFERENT ROAD AND WEATHER CONDITIONS.

LEVEL "1" IS RECOMMENDED FOR EXPERT RIDERS IN IDEAL ROAD SURFACE CONDITIONS.

ALL OTHER LEVELS ARE INTERMEDIATE SETTINGS BETWEEN LEVEL "1" AND LEVEL "8".

To deactivate the system, set the control level to "0".

The a-PRC indicator light is constantly lit.

CAUTION

WHEN THE ATC SYSTEM DEACTIVATED, A POPUP WITH THE MESSAGE "ATC DISABLED" IS SHOWN ON THE SCREEN TO WARN THE RIDER THAT THERE IS NO TRACTION CONTROL ASSISTANCE.

THIS POPUP CLEARS AFTER 5 SECONDS.

NOTE

THIS IS ALSO POSSIBLE WITH THE MOTORCYCLE IN MOTION.

NOTE

WHEN THE BATTERY IS CONNECTED FOR THE FIRST TIME, THE a-PRC INDICATOR LIGHT IS CONSTANTLY LIT (SYSTEM NOT ACTIVE)

NOTE

IF THE IGNITION SWITCH IS TURNED OFF AND LEFT OFF FOR MORE THAN 30 SECONDS, AT THE NEXT KEY-ON, THE ATC SYSTEM MAINTAINS THE SETTINGS SELECTED PREVIOUSLY.

AWC can only be activated if the **ATC** system is active. In other terms, the wheelie control function cannot be activated unless the traction control system has already been activated. Disabling **ATC** also automatically disables **AWC**.

Aprilia Wheelie Control

Wheelie control: a system designed to help the rider control wheelieing by reducing torque to gently lower the front wheel to the ground.

While AWC improves vehicle control, it does not allow the physical handling limits of the vehicle to be exceeded. The rider is fully responsible for riding at a suitable speed based on weather and road conditions, always leaving an appropriate safety margin.

Under no circumstances can AWC compensate for any rider error or improper use of the throttle.

The AWC system may be ACTIVE or DEACTIVATED.

CAUTION

WITH THE AWC DISABLED AND ATC ENABLED, WHEELING IS NOT ALLOWED FOR MORE THAN 10 SECONDS; ONCE THIS LIMIT IS EXCEEDED, THE SYSTEM BRINGS THE FRONT WHEEL BACK TO THE GROUND;

Aprilia Quick Shift

It is a system that allows go up and down the gears without having to use the clutch 'and without changing the position of the throttle grip.

It uses the gear shift sensor signal on the gear lever to shift gears more quickly with a lower decrease in rpm than a traditional gear shift as regards upshifting.

The system is only active above an engine speed: of approximately 3,000 rpm.

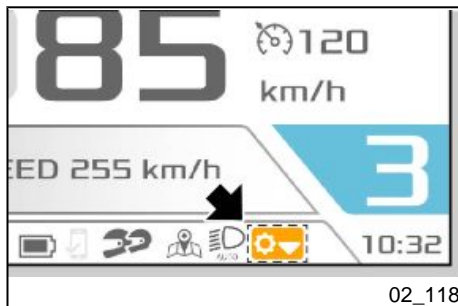

02_118

CAUTION

THE CLUTCH MUST BE USED FOR UPSHIFTS AT ENGINE SPEEDS BELOW 3,000 RPM.

CAUTION

THE SYSTEM IS ACTIVE WHEN SHIFTING UP ONLY WITH THE THROTTLE OPEN.

It can operate when downshifting as long as all the required conditions are met, including an rpm less than the maximum threshold, which varies according to the gear. If the downshifting system is not available temporarily for some reason (e.g. RPM too high, first gear engaged), the instrument panel icon will be orange.



02_119

PIT

This button activates the PIT LANE function (in RACE mode only), which limits the speed of the vehicle in a predetermined geographical area, such as the pit lane on a race track.

Once the function has been activated from the relative menu (see chapter "ADVANCED FUNCTIONS"), pushing the PIT selector briefly to the left activates the function, and the chequered flag symbol appears on the digital display to confirm that the function is active.

To deactivate the PIT LANE function, press the PIT button again briefly to the left or change gear.

The PIT function may be set within a speed range from 30-90 km/h (19-56 mph)

CAUTION

THE PIT LANE FUNCTION CAN ONLY BE ACTIVATED WITH THE VEHICLE IN FIRST GEAR.

**CAUTION**

WHEN THE SYSTEM IS ACTIVE, THE IMMOBILIZER INDICATOR LIGHT FLASHES.

TABLE OF RECOMMENDED SETTINGS

Engine map	ATC	AWC	ABS	AEM	AEB	ASC	ALC	Road surface
User	5	1	2	2	2	A3	2	Customisable (all parameters may be modified)
STREET	6	3	2	3	3	A3	3	Daily use on the road
Sport	5	2	2	2	2	A3	2	Dry road, excellent grip conditions
TRACK 1	3	1	1	2	2	A1	1	Customisable (all parameters may be modified)
TRACK 2	2	OFF	1	1	1	M1	1	Customisable (all parameters may be modified)
Race	4	1	1	2	2	A2	1	Dedicated to the track, limited engine brake

ATC: LEVELS 7 / 8 ARE TO BE USED IN POOR GRIP, RAIN CONDITIONS

ABS: LEVEL 3 IS TO BE USED IN POOR GRIP, RAIN CONDITIONS.

AWC LEVEL 3 IS FOR USERS WHO WANT A GUIDE FREE OF SURGES.

NOTE

THE TABLE IS ONLY INTENDED AS A GUIDELINE FOR SETTING THE LEVELS OF EACH CONTROL SYSTEM. EACH RIDER MAY PERSONALISE THE LEVELS TO THEIR OWN PREFERENCE IN ACCORDANCE WITH ABILITY, RIDING STYLE AND ROAD CONDITIONS.

THE ONLY RIDING MODES THAT CAN BE MODIFIED ARE USER (IN THE ROAD MODE), TRACK1 AND TRACK2 (IN THE RACE MODE)

FOR MORE INFORMATION ON LEVEL SETTINGS, SEE THE RELATIVE PARAGRAPHS FOR EACH INDIVIDUAL FUNCTION.

a-PRC SYSTEM INDICATOR LIGHT KEY

- **Indicator light off:** with system activated with vehicle in motion or system activated after exceeding 5 Km/h (3.1 mph) after key-on;
- **Indicator light continuously lit:** system deactivated deliberately by rider, or deactivated as a result of a malfunction;
- **Indicator light flashing slowly:** with system active after key-on before exceeding 5 Km/h (3.1 mph) or in the case of certain malfunctions causing ATC level to be locked ("+" and "-" buttons disabled);
- **Indicator light flashing quickly:** when one of the a-PRC functions (ATC, AWC and ALC) is actively invoking traction control.

Immobilizer system operation (02_121, 02_122, 02_123)

For enhanced theft protection, the vehicle is equipped with an electronic immobilizer system that is activated automatically when the ignition key is removed.

Keep the second key in a safe place since it is not possible to make a copy if it gets lost.

This would imply replacing numerous parts of the vehicle (besides the locks).

Each key in the grip has an electronic device - transponder - which modulates the radio frequency signal emitted by a special aerial inside the switch when the vehicle is started.

The modulated signal is the "password" by which the appropriate central unit recognises the key and only after this occurs, it allows the engine start-up.

CAUTION

THE IMMOBILIZER SYSTEM CAN MEMORISE UP TO FOUR KEYS.

DATA STORAGE OPERATION CAN ONLY BE PERFORMED AT AN Authorised Aprilia DEALER.

DATA STORAGE PROCEDURE CANCELS THE EXISTING CODES. THEREFORE, IF A CUSTOMER WANTS TO PROGRAM SOME NEW KEYS, S/HE SHOULD GO TO THE DEALER TAKING ALL THE KEYS S/HE WANTS TO ENABLE.

In the event the instrument panel detects a fault with the immobilizer system when the key is connected, you will need to enter the user code to start the motorcycle. At the same time the indicator light appears on the instrument panel, the general red warning light will come on.

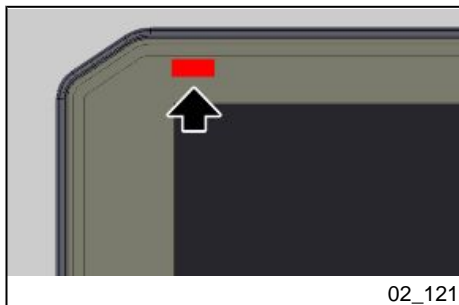

02_121

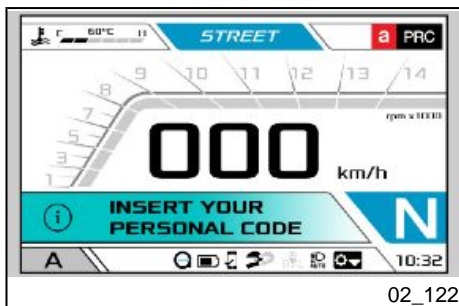

02_122

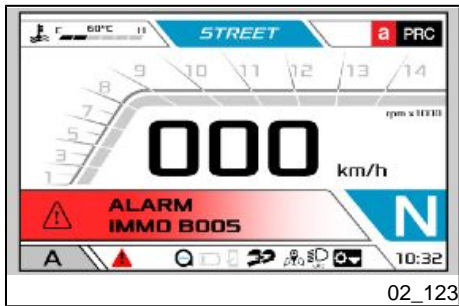

Once the code has been correctly entered, the error will be displayed on the screen. It is then possible to start the motorcycle so you can go immediately to an Authorised **Aprilia** Dealership.

CAUTION

PRESSING OR MOVING ANY CONTROL ON THE LEFT SWITCH CLUSTER, IT IS POSSIBLE TO REMOVE THE ERROR NOTIFICATION SCREEN, BUT THE SCREEN WILL BE VISIBLE AGAIN AFTER ABOUT 10 SECONDS.



The saddle (02_124, 02_125, 02_126, 02_127, 02_128, 02_129, 02_130, 02_131)

REMOVAL TAIL FAIRING / PASSENGER SEAT

- Turn the key clockwise.
- Lift and remove the tail fairing / passenger seat.



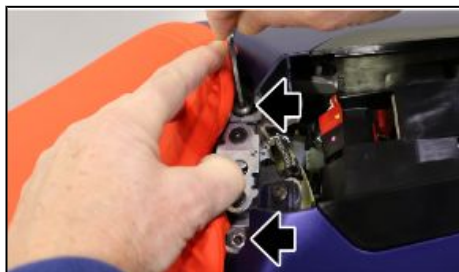

02_126

RIDER SADDLE REMOVAL

- Using the supplied hex key, unscrew and remove the two saddle fixing screws in order to remove it from the vehicle.



02_127

RIDER SADDLE INSTALLATION

- Perform the above described steps in reverse order.
- After refitting and fixing the saddle, place the hexagonal wrench in the corresponding seat of the tail fairing / passenger seat.

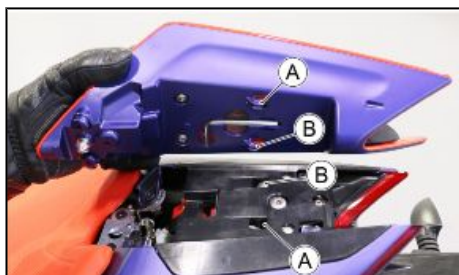

02_128

TAIL FAIRING INSTALLATION

- Place the tail fairing by aligning the two hooks (A) and (B) with their seats (A) and (B) on the vehicle.



- Press the tail fairing downward with one hand and with the other push it backward until it is completely coupled.



PASSENGER SADDLE INSTALLATION

- Place the saddle by aligning the hook (C) with its seat (C) on the vehicle.



- Press the saddle downward with one hand and with the other push it backward until it is completely coupled.

CAUTION

BEFORE RIDING, MAKE SURE THAT THE SADDLE IS PROPERLY FIXED. IF THE PASSENGER SEAT IS FITTED ON THE VEHICLE, MAKE SURE IT IS PROPERLY FIXED BEFORE ALLOWING THE PASSENGER TO SIT ON IT.

THE TAIL FAIRING CAN BE USED INSTEAD OF THE PASSENGER SEAT; HOWEVER, WITH THE TAIL FAIRING IN PLACE, PASSENGERS SHOULD NOT BE TRANSPORTED. PASSENGER TRANSPORT ON THE TAIL FAIRING IS ILLEGAL, AND IT IS EXTREMELY LIKELY THAT THE PASSENGER WILL FALL FROM THE VEHICLE.

Identification (02_132, 02_133)

Write down the chassis and engine number in the specific space in this booklet. The chassis number is handy when purchasing spare parts.

CAUTION

THE MODIFICATION OF THE IDENTIFICATION CODES IS A SERIOUS PUNISHABLE CRIME. HOWEVER, THE LIMITED WARRANTY FOR NEW VEHICLES WILL BE VOID IF THE VEHICLE IDENTIFICATION NUMBER (VIN) HAS BEEN MODIFIED OR NOT PROMPTLY DETERMINED.

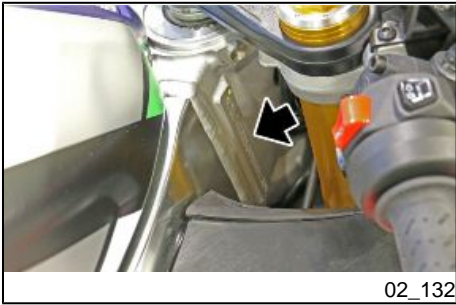

CHASSIS NUMBER

The chassis number is stamped on the RH side of the headstock.

Chassis No.

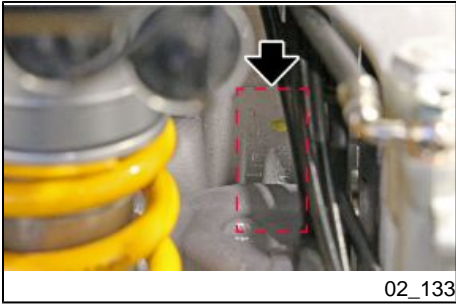

ENGINE NUMBER

The engine number is stamped on the engine crankcase, at the rear near the shock absorber.

Engine No.

RSV4 1100



Chap. 03
Use

Checks (03_01)

CAUTION



BEFORE SETTING-OFF, ALWAYS CARRY OUT A PRELIMINARY CHECK OF THE VEHICLE, SO THAT IT OPERATES CORRECTLY AND SAFELY. FAILURE TO DO SO MAY LEAD TO SERIOUS PERSONAL INJURIES OR VEHICLE DAMAGE. CONTACT AN Authorised Aprilia Dealer IMMEDIATELY IF IN ANY DOUBT ABOUT THE FUNCTIONS OF ANY CONTROLS OR IF ANY MALFUNCTIONS ARE FOUND OR SUSPECTED. IT DOES NOT TAKE MUCH TIME TO DO A CHECK AND THE SAFETY BENEFITS ARE CONSIDERABLE.



This vehicle has been programmed to indicate in real time any operation failure stored in the electronic control unit memory.

Every time the ignition switch is turned to "ON", the alarm LED warning lights turn on for about three seconds on the dashboard.

PRE-RIDE CHECKS

Front and rear disc brake

Check for proper operation. Check brake lever empty travel and brake fluid level. Check for leaks. Check

	brake pads for wear. If necessary top-up with brake fluid.
Throttle grip	Check that the grip rotates smoothly and without impediment.
Engine oil	Check and/or top-up as required.
Wheels/ tyres	<p>Check that tyres are in good conditions. Check inflation pressure, tyre wear and potential damage.</p> <p>Remove any possible strange body that might be stuck in the tread design.</p>
Brake levers	<p>Check they function smoothly.</p> <p>Lubricate the joints and adjust the travel if necessary.</p>
Clutch lever	Check correct operation and empty travel. Check the condition of the cable on the handlebar and on the engine. The cable must be replaced if it shows any signs of fraying. Lubricate the joints if necessary.
Steering	Makes sure that the steering turns freely, is even, smooth and with zero play or slackening to the limit stop on both sides.
Side stand	Check that it slides smoothly and that it snaps back to its rest position

upon spring tension. Lubricate couplings and joints if necessary.

Check that the side stand safety switch functions correctly.

Clamping elements	Check that the clamping elements are not loose. Adjust or tighten them as required.
Fuel tank	Check level and refill if necessary. Check the circuit for leaks or obstructions. Check that the tank cap closes correctly.
Engine stop switch (ON - OFF)	Check function.
Lights, warning lights, horn, rear stop light switch and electrical devices	Check function of horn and lights. Replace bulbs or repair any faults noted.
Tone wheels	Check that the tone wheels are perfectly clean and in good conditions.

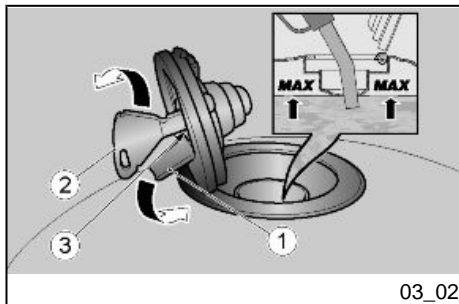

Refuelling (03_02, 03_03)

To refuel:

- Lift the cover (1).
- Insert the key (2) into the fuel tank cap lock (3).
- Turn the key clockwise, pull and open the fuel filler cap.

CAUTION



ALWAYS USE PETROL WITH A MAXIMUM OF 10% BIOETHANOL CONTENT (E10).

DO NOT USE PETROL WITH AN ETHANOL CONTENT HIGHER THAN 10%; THIS USE COULD DAMAGE THE FUEL SYSTEM COMPONENTS AND/OR COMPROMISE ENGINE PERFORMANCE.

Characteristic

Fuel tank capacity (including reserve)

17.9 l (3.93 UK gal; 4.72 US gal)

Fuel tank reserve capacity

4 l (0.88 UK gal; 1.06 US gal)

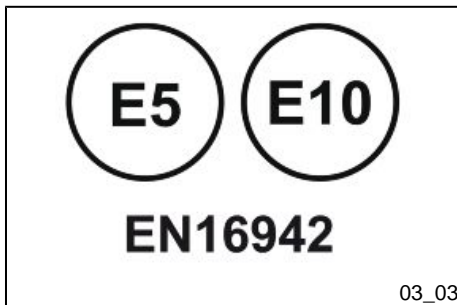

The EN16942 European standard requires the identification of the compatibility of the vehicles with the fuel type by means of a graphic symbol for consumer information. The symbols listed below facilitate the recognition of the correct fuel type to be used on your vehicle. Before refuelling, check the symbols located near the filler neck and compare them with the symbol shown on the filling pump.

E5: unleaded gasoline with 5% maximum Ethanol percent.

E10: unleaded gasoline with 10% maximum Ethanol percent.

The label on each pump dispenser shows only one value; if for example it shows E5 it means that the petrol supplied is unleaded, with 5% ethanol.

However, the label on the vehicle may show several values. If, for example, it shows both E5 and E10 values, it means that the vehicle is compatible with gasoline containing maximum 10% Ethanol and thus the Customer may refuel either from a E5 dispenser or from a E10 dispenser (but not from an E85 dispenser).

- Refill.

CAUTION



**DO NOT ADD ADDITIVES OR ANY OTHER SUBSTANCES TO THE FUEL.
WHEN USING A FUNNEL, ENSURE THAT IT IS PERFECTLY CLEAN.**



DURING REFUELLING AVOID FUEL LEAKAGES, WHICH MAY CAUSE DAMAGE TO THINGS OR PERSONS AND FIRE HAZARD.

DURING REFUELLING, AVOID THE USE OF ELECTRIC DEVICES AND/OR MOBILE PHONES, BECAUSE FUEL VAPOURS MAY CAUSE DAMAGE TO OBJECTS AND/OR PERSONAL INJURIES.

After refuelling:

- The cap can only be closed if the key (2) is inserted.
- Once the key (2) is inserted, press the cap to close it again.
- Remove the key (2).
- Close the cover (1).



MAKE SURE THE CAP IS TIGHTLY CLOSED.

Rear shock absorbers adjustment (03_04, 03_05)

The rear suspension consists of a spring-shock absorber unit linked to the frame via uniball joints and to the swingarm via a linkage system.

To adjust the rear shock absorbers, proceed as follows:

OHLINS

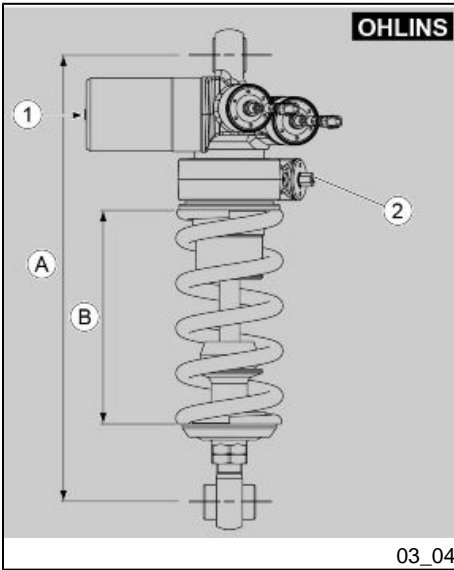

RSV4 1100 Factory (Ohlins shock absorber - ASC)

- Using an adequate key, operate on the adjusting ring nut (2) to adjust the spring pre-loading (B).
- The damping, compression, rear extension, braking and turning acceleration assistance are electronically adjusted.

To perform these adjustments, refer to paragraph "ADVANCED FUNCTIONS" in the "VEHICLE" chapter.

Each adjustment is described in detail at paragraph "a-PRC SYSTEM", under the "ASC" section



TO AVOID COMPROMISING SHOCK ABSORBER OPERATION, DO NOT LOOSEN THE SCREW (1) AND DO NOT TAMPER WITH THE SEAL UNDERNEATH, AS NITROGEN MAY COME OUT RESULTING IN RISK OF ACCIDENTS.

NOTE

THE VEHICLE HAS A HEIGHT ADJUSTABLE SUSPENSION (A).

TO CHANGE THE HEIGHT, YOU MUST CONTACT AN Authorised Aprilia Dealer.

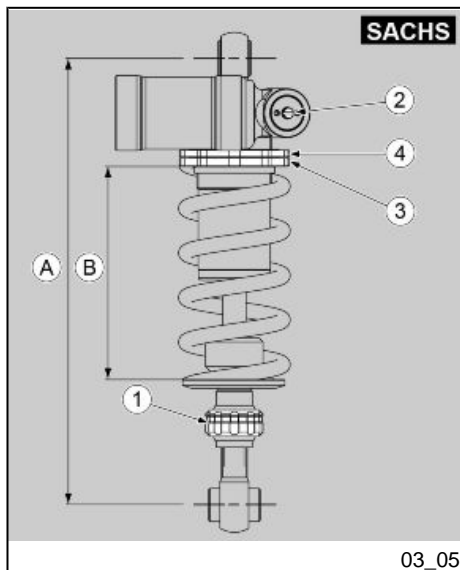

RSV4 1100 (Sachs shock absorber - NO ASC)

- To adjust the rebound damping, turn the ring nut (1);
- To adjust the compression damping, turn the screw (2);
- To adjust the spring pre-load (B), using an appropriate wrench, unscrew the locking ring nut (4) and turn the adjusting collar (3). Once the adjustment is completed, tighten the ring nut (4).

NOTE

THE VEHICLE HAS A HEIGHT ADJUSTABLE SUSPENSION. FOR USE ON THE TRACK PLEASE OBSERVE THE VALUES RECOMMENDED FOR USE ON THE ROAD.

TO CHANGE THE HEIGHT, YOU MUST CONTACT AN Authorised Aprilia Dealer.

CAUTION

CARRY OUT MAINTENANCE OPERATIONS AT HALF THE INTERVALS SPECIFIED IF THE VEHICLE IS USED IN PARTICULAR RAINY OR DUSTY CONDITIONS, OFF ROAD OR FOR TRACK USE.

REAR SHOCK ABSORBER STANDARD SETTING IS ADJUSTED TO MEET SPORTING RIDING.

IN ANY CASE IT IS POSSIBLE TO INSERT PERSONAL SETTINGS, DEPENDING ON VEHICLE UTILIZATION.



RACING TRACK SETTINGS MUST BE DONE ONLY FOR OFFICIAL COMPETITIONS OR SPORTS EVENTS WHICH ARE, IN ALL CASES, AWAY FROM NORMAL ROAD TRAFFIC AND WITH THE AUTHORISATION OF THE RELEVANT AUTHORITIES.

IT IS STRICTLY FORBIDDEN TO RIDE A VEHICLE SET FOR RACING ON ROADS AND MOTORWAYS.



TO COUNT THE NUMBER OF CLICKS AND/OR REVOLUTIONS OF ADJUSTMENT SETTINGS ALWAYS START FROM THE MOST RIGID SETTING (WHOLE CLOCKWISE ROTATION OF THE SETTING).

TO AVOID DAMAGE, DO NOT FORCE THE ADJUSTERS BEYOND THE MAXIMUM SETTING POSITION IN EITHER DIRECTION.



SET SPRING PRE-LOADING AND SHOCK ABSORBER REBOUND DAMPING ACCORDING TO THE VEHICLE USE CONDITIONS.

IF THE SPRING PRE-LOADING IS INCREASED, IT IS NECESSARY TO INCREASE THE REBOUND DAMPING ACCORDINGLY TO AVOID SUDDEN JERKS WHEN RIDING.

CAUTION

ALWAYS OBSERVE THE RECOMMENDED ADJUSTMENT RANGE.

CAUTION

FOR THE CORRECT SETTING PARAMETERS, READ THE PARAGRAPH "SETTING THE REAR SHOCK ABSORBER" CAREFULLY.

TAKE YOUR VEHICLE TO AN Authorised Aprilia Dealer, IF NECESSARY.

TRY RIDING THE VEHICLE ON THE STREET UNTIL THE OPTIMUM ADJUSTMENT IS OBTAINED.

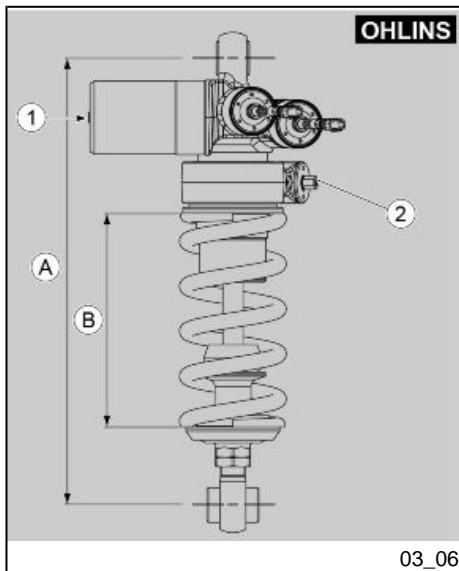

Rear shock absorbers setting (03_06, 03_07)

RSV4 1100 Factory (Ohlins shock absorber - ASC)



SPORT SETTINGS MAY BE USED ONLY FOR OFFICIAL COMPETITIONS TO BE CARRIED OUT ON TRACKS, AWAY FROM NORMAL ROAD TRAFFIC AND WITH THE AUTHORISATION OF THE RELEVANT AUTHORITIES.

Operate on the adjusting ring nut (2) as follows, to adjust the spring pre-loading (B):

Standard adjustment:

- Spring pre-load: 4 turns from the adjustment ring nut completely unscrewed
- ASC mode: A3-M3

Racing adjustment:

- Spring pre-load: 14 turns from the adjustment ring nut completely unscrewed
- ASC mode: A1-M1 / A2-M2

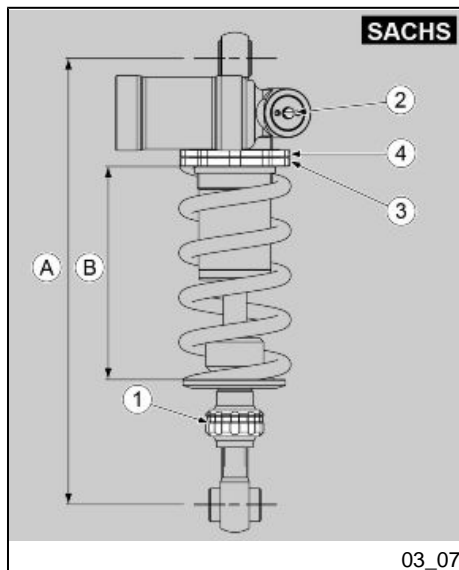

RSV4 1100 (Sachs shock absorber - NO ASC)



SPORT SETTINGS MAY BE USED ONLY FOR OFFICIAL COMPETITIONS TO BE CARRIED OUT ON TRACKS, AWAY FROM NORMAL ROAD TRAFFIC AND WITH THE AUTHORISATION OF THE RELEVANT AUTHORITIES.

STANDARD ADJUSTMENT (FOR ROAD USE)

Shock absorber centre-to-centre distance (A)	312 mm (12.28 in)
(preloaded) Spring (B) length	148 mm (5.83 in)
Rebound adjustment, ring nut (1)	open (**) 20 clicks from fully closed (*)
Compression adjustment, adjuster (2)	open (**) 2 turns from fully closed (*)

RACING ADJUSTMENT (TRACK USE ONLY)

Shock absorber centre-to-centre distance (A)	314 mm (12.36 in)
(preloaded) Spring (B) length	144 mm (5.67 in)
Rebound adjustment, ring nut (1)	open (**) 8 clicks from fully closed (*)
Compression adjustment, adjuster (2)	open (**) 1-2 turns from fully closed (*)

(*) = clockwise

(**) = anticlockwise

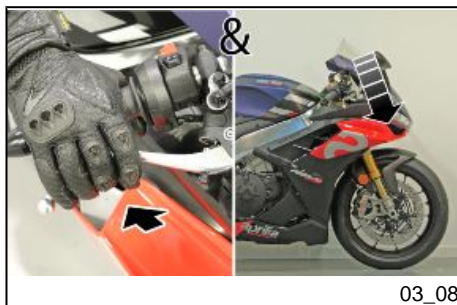
**Front fork adjustment (03_08, 03_09, 03_10, 03_11, 03_12)**

- Operating the front brake lever, press the handlebar repeatedly to send the fork fully down. The shock absorber should compress and extend smoothly with no signs of oil leakage on the stanchions.
- Check the tightening of all the elements and the correct operation of the front and rear suspension joints.

CAUTION

PLEASE CONTACT AN Authorised Aprilia Dealer TO HAVE THE FRONT FORK OIL CHANGED AND ITS OIL SEALS REPLACED.

The front suspension consists of a hydraulic fork connected to the headstock by means of two plates.

To adjust the front suspension, proceed as follows:

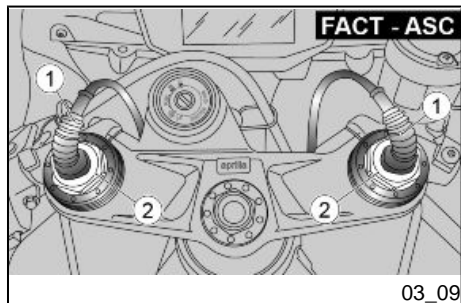

RSV4 1100 Factory (Ohlins fork - ASC)

- The spring pre-load is set in the factory to satisfy any type of driving and therefore it is not recommended to modify its value.

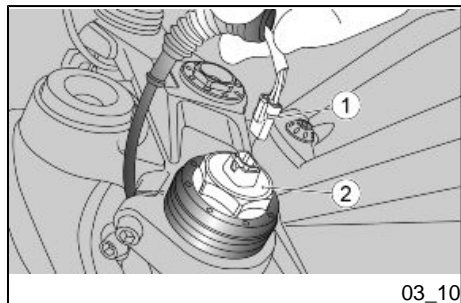

- To adjust the spring pre-load, disconnect the connector (1) from the electronic forks to be able to reach the adjustment nut (2) located on the cap.



TO AVOID DAMAGING THE CONNECTOR, PRESS THE TAB (3) ON THE INDICATED POINT AND THEN CAREFULLY REMOVE THE CONNECTOR.



PAY SPECIFIC ATTENTION WHEN DISCONNECTING THE CONNECTORS, TO AVOID DAMAGING THEM, WHICH WOULD COMPROMISE THE OPERATION OF THE VEHICLE.

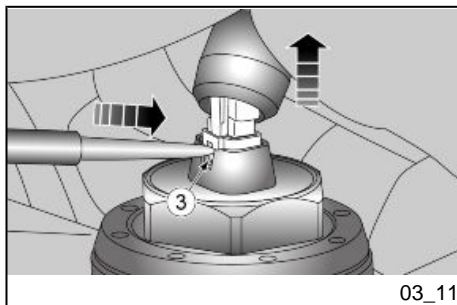

03_11



SET THE SPRING PRE-LOADING AND THE EXTENSION HYDRAULIC BRAKING OF THE FRONT FORK ACCORDING TO THE VEHICLE USE CONDITIONS.

BY INCREASING THE SPRING PRE-LOAD, THE CONTROL PARAMETERS OF THE FRONT FORK MUST BE ADJUSTED (BY INCREASING THEIR VALUES) TO AVOID UNEXPECTED JOLTS WHILE DRIVING.

- The damping, compression, rear extension, braking and turning acceleration assistance are electronically adjusted.

To perform these adjustments, refer to paragraph "ADVANCED FUNCTIONS" in the "VEHICLE" chapter.

Each adjustment is described in detail at paragraph "a-PRC SYSTEM", under the "ASC" section

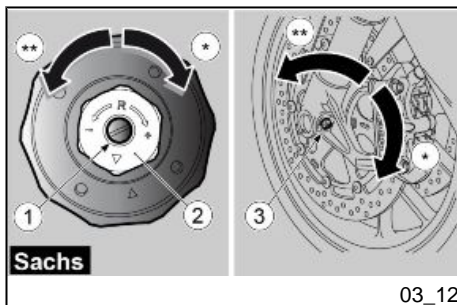

03_12

RSV4 1100 (Sachs forks - NO ASC)

Each stanchion is equipped with:

- An upper adjuster (1) to set the extension of the hydraulic brake;
- An upper nut (2) to adjust the spring preload;
- A lower adjuster (3) to set the compression of the hydraulic brake.



TO AVOID DAMAGE, DO NOT FORCE THE ADJUSTERS BEYOND THE MAXIMUM SETTING POSITION IN EITHER DIRECTION. SET THE SAME SPRING PRE-LOAD AND HYDRAULIC DAMPING SETTING FOR BOTH STANCHIONS: RIDING THE VEHICLE WITH DIFFERENT SETTINGS FOR THE TWO STANCHIONS REDUCES STABILITY. WHEN SPRING PRE-LOAD IS INCREASED, REBOUND

DAMPING MUST ALSO BE INCREASED TO PREVENT EXCESSIVE SUSPENSION KICKBACK WHEN RIDING.

The standard front fork setting is adjusted to suit most high and low speed riding conditions, whether the vehicle is partially or fully loaded.

However, the setting can be modified for specific needs according to vehicle use.

CAUTION

FOR THE CORRECT SETTING PARAMETERS, READ THE PARAGRAPH "SETTING THE FRONT FORK" CAREFULLY.

TAKE YOUR VEHICLE TO AN Authorised Aprilia Dealer, IF NECESSARY.

Front fork setting (03_13, 03_14, 03_15, 03_16)

RSV4 1100 Factory (Ohlins fork - ASC)

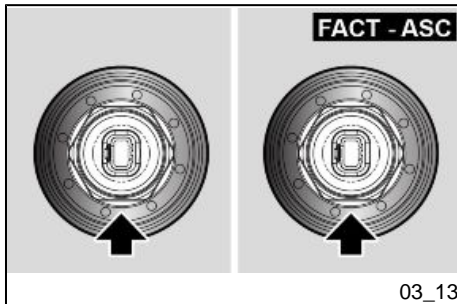

The forks can be adjusted as follows:

Standard adjustment:

- Spring pre-load (2): 5 turns from the adjustment ring nut completely unscrewed
- ASC mode: A3-M3
- Stems (A) (***) protrusion from top plate: 3 notches

Racing adjustment:

- Spring pre-load (2): 5 turns from the adjustment ring nut completely unscrewed
- ASC mode: A1-M1 / A2-M2

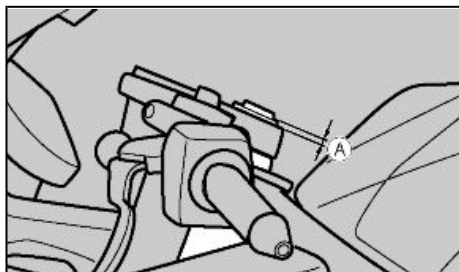

03_14

- Stems (A) (***) protrusion from top plate: 3 notches

(***) - this type of adjustment may only be made by an **Authorised Aprilia Dealer**.

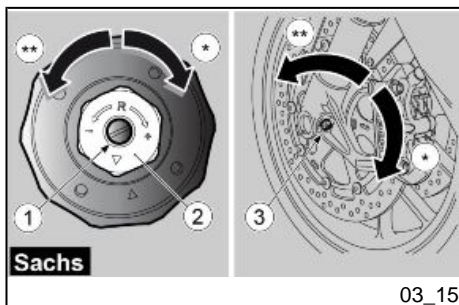

03_15

RSV4 1100 (Sachs forks - NO ASC)



TO COUNT THE NUMBER OF CLICKS AND/OR REVOLUTIONS OF ADJUSTMENT SETTINGS ALWAYS START FROM THE MOST RIGID SETTING (WHOLE CLOCKWISE ROTATION OF THE SETTING).

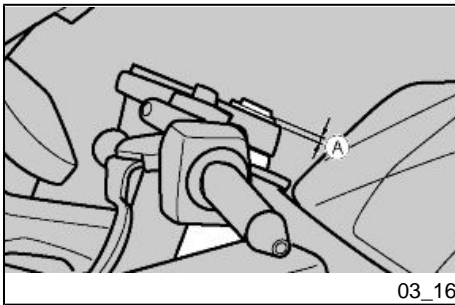

STANDARD ADJUSTMENT (FOR ROAD USE)

Rebound damping adjustment, screw (1)	Unscrew (**) 10 clicks from fully closed (*)
Hydraulic compression adjustment, adjuster (3)	Unscrew (**) 6 clicks from fully closed (*)
Spring pre-loading, nut (2)	screw (*) 5 turns from fully open (**)
Stanchion protrusion (A) (***) from top yoke (excluding cover)	2 notches/ 8 mm (2 notches/0.31 in)

RACING ADJUSTMENT (TRACK USE ONLY)

Rebound damping adjustment, screw (1)	Unscrew (**) 8 clicks from fully closed (*)
---------------------------------------	---

Hydraulic compression adjustment, adjuster (3)	Unscrew (**) 4 clicks from fully closed (*)
Spring pre-loading, nut (2)	screw (*) 6 turns from fully open (**)
Stanchion protrusion (A) (***) from top yoke (excluding cover)	2 notches/ 8 mm (2 notches/0.31 in)

(*) - Clockwise

(**) - Anticlockwise

(***) - this type of adjustment may only be made by an **Authorised Aprilia Dealer**.

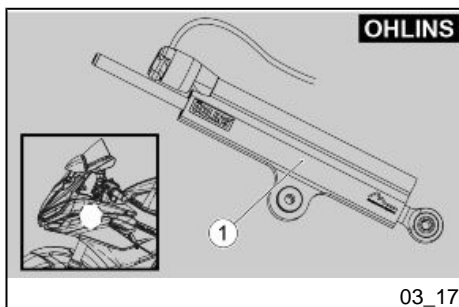

Steering shock absorber adjustment (03_17, 03_18)

RSV4 1100 Factory (Ohlins shock absorber - ASC)

The steering damper can be electronically adjusted, refer to paragraph "ADVANCED FUNCTIONS" in the "VEHICLE" chapter.

The type of adjustment that can be performed is described in detail at paragraph "a-PRC SYSTEM", under the "ASC" section.



SPORT SETTINGS MAY BE USED ONLY FOR OFFICIAL COMPETITIONS TO BE CARRIED OUT ON TRACKS, AWAY FROM NORMAL ROAD TRAFFIC AND WITH THE AUTHORISATION OF THE RELEVANT AUTHORITIES.



CARRY OUT THE ADJUSTMENT ONLY WHEN THE VEHICLE IS AT STANDSTILL. AFTER CHANGING THE ADJUSTMENTS, ALWAYS ENSURE THAT THE STEERING IS FREE IN BOTH ROTATION DIRECTIONS.

The steering damper can be adjusted as follows:

Standard adjustment:

- ASC mode: A3-M3

Racing adjustment:

- ASC mode: A1-M1 / A2-M2

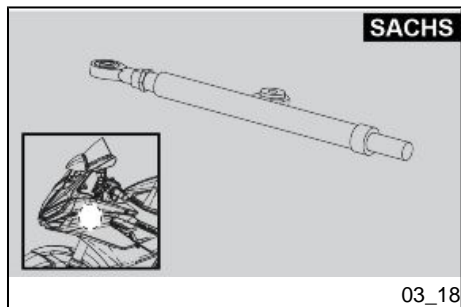

ONLY FOR VERSION RSV4 1100:

The **RSV4 1100** version is fitted with a non-adjustable steering damper. No adjustments can be carried out.

Justering af greb til forbremse (03_19)

It is possible to adjust the distance between the end of the lever (1) and the grip (2), turning the adjuster (3).

- Push the control lever (1) forwards and turn the adjuster (3) until the lever (1) is at the desired distance.
- Turning the adjuster anticlockwise, the lever (1) gets closer to the grip (2).

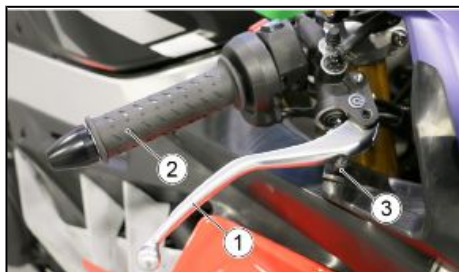

03_19

Clutch lever adjustment (03_20, 03_21)

The clutch lever play (1) can be adjusted acting on the set screw (3).

- Turn the set screw (3) toward the direction of motion to increase the lever play (1) and check operation of the guide using the knob (2) as in riding position.
- Ensure that the play is between 1 and 3 mm (0.039 and 0.12 in).

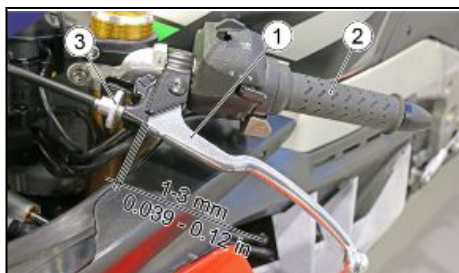

03_20

CAUTION

IF YOU WANT TO CHANGE THE STANDARD ANGLE OF THE CLUTCH LEVER, YOU MUST ENSURE THAT WITH THE LEVER FULLY PULLED, THERE IS ABSOLUTELY NO INTERFERENCE WITH THE "-" BUTTON. FAILURE TO OBSERVE THIS COULD CAUSE THE a-PRC SYSTEM TO MALFUNCTION.



03_21

Running in

Running in is essential to ensure the durability of the vehicle. During the first 1000 Km (621 mi), observe the following rules to ensure the reliability and performance of the vehicle throughout its lifetime:

- Avoid full throttle starts and hard acceleration;
- Avoid hard or prolonged braking;
- Do not ride for prolonged periods at sustained high speed; preferably ride the motorcycle on varied routes with frequent, gentle acceleration and deceleration;
- Ride prudently to gradually gain familiarity with the motorcycle, testing progressively higher throttle apertures only as you gain confidence

CAUTION

THE FULL PERFORMANCE OF THE VEHICLE IS ONLY AVAILABLE AFTER THE SERVICE AT THE END OF THE RUNNING IN PERIOD.

Follow these guidelines:

- Do not fully open the throttle grip abruptly at low engine speeds, either during or after the running in period.
- During the first 100 Km (62.14 miles) use the brakes gently, avoiding sudden or prolonged braking. That is to permit the adequate adjustment of the pad friction material to the brake discs.
- It is advisable to not exceed 7500 rpm for the first 1000 km (621.37 mi) and then not to exceed 9500 rpm up until 2000 km (1242.74 mi).

CAUTION

AFTER THE SPECIFIED MILEAGE, TAKE YOUR VEHICLE TO AN Authorised Aprilia Dealer FOR THE CHECKS INDICATED IN THE "SCHEDULED MAINTENANCE TABLE" IN THE SCHEDULED MAINTENANCE SECTION, TO AVOID INJURING YOURSELF, OTHERS AND /OR DAMAGING THE VEHICLE.

Starting up the engine (03_22, 03_23, 03_24)

This vehicle is extremely powerful and must be used carefully and driven with caution and respect for its power and potential.

Do not place objects inside the top fairing (between the handlebar and the instrument cluster), as this may impede the movements of the handlebar and obstruct visibility of the instruments.



EXHAUST FUMES CONTAIN CARBON MONOXIDE, AN EXTREMELY HARMFUL SUBSTANCE IF INHALED.

NEVER START THE ENGINE IN A CLOSED OR INSUFFICIENTLY VENTILATED SPACE.



FAILURE TO OBSERVE THIS WARNING COULD LEAD TO UNCONSCIOUSNESS AND EVEN DEATH DUE TO SUFFOCATION.

CAUTION

WITH THE SIDE STAND LOWERED, THE ENGINE MAY ONLY BE STARTED WITH THE GEARBOX IN NEUTRAL. IF YOU ATTEMPT TO ENGAGE THE GEAR, THE ENGINE WILL STOP.

WITH THE SIDE STAND RETRACTED, THE ENGINE MAY BE STARTED WITH THE GEARBOX IN NEUTRAL OR WITH THE GEAR ENGAGED AND THE CLUTCH LEVER OPERATED.



- Get on the motorcycle, assuming the correct driving posture.
- Make sure that the side stand has been fully retracted.
- Operate the front or rear brake (or both).
- Operate the clutch lever (1) and make sure that the transmission (2) is in neutral.



- Set the switch for stopping the engine (3) on "RUN" Turn the ignition key (4) to "ON".

At this stage:

- The starting screen will be displayed on the digital display for about 2 seconds and then the screen with the standard parameters will appear.
- All the indicator lights on the dashboard will come on for about 2 seconds.
- Press the starter button once only.
- With the engine operating normally, the number of rpm at which the engine is operating will be displayed instantaneously.



IF THE LOW FUEL WARNING LIGHT ON THE DASHBOARD TURNS ON, REFUEL THE VEHICLE AT ONCE.



INTENSE USE/ON THE TRACK IN RESERVE CAN DAMAGE THE ENGINE.



ON NEW VEHICLES, THE SHIFT LIGHT THRESHOLD IS SET TO 13,400 RPM.

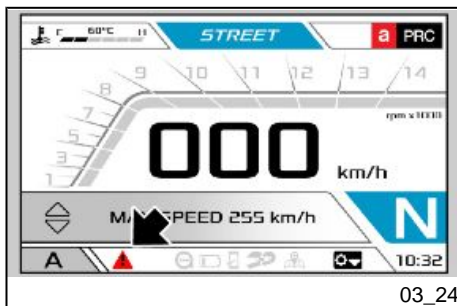

IF THE GENERAL WARNING SYMBOL IS SHOWN IN THE DIGITAL DISPLAY, IT MEANS THAT THE CONTROL UNIT HAS ENCOUNTERED A FAULT, THEREFORE IT IS NECESSARY TO CONTACT AN Authorised Aprilia Dealer.



DO NOT SET OFF SUDDENLY WHEN THE ENGINE IS COLD. RIDE AT LOW SPEED FOR SEVERAL KILOMETRES. THIS WILL ALLOW THE ENGINE TO WARM UP AND REDUCE POLLUTING EMISSIONS AND FUEL CONSUMPTION.

Moving off / riding (03_25, 03_26, 03_27, 03_28)

CAUTION

WHEN TRAVELLING WITHOUT PASSENGERS, MAKE SURE THE PASSENGER FOOTRESTS ARE FOLDED UP.

CAUTION

PASSENGERS MUST BE SUITABLY INSTRUCTED ON HOW TO BEHAVE TO PREVENT DANGEROUS SITUATIONS WHEN RIDING.

BEFORE SETTING OFF, MAKE SURE THE STAND HAS BEEN COMPLETELY RETRACTED TO ITS POSITION.

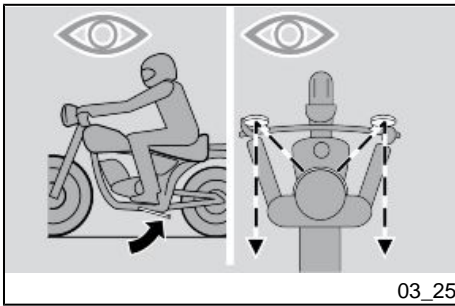

To start:

- Turn on the engine.
- Adjust the inclination of the rear-view mirrors to ensure proper visibility.

CAUTION



WITH THE VEHICLE AT STANDSTILL, PRACTICE USING THE REAR-VIEW MIRRORS. THE MIRRORS ARE CONVEX, SO OBJECTS MAY SEEM FARTHER AWAY THAN THEY REALLY ARE. THESE MIRRORS OFFER A WIDE-ANGLE VIEW AND ONLY EXPERIENCE HELPS YOU JUDGE THE DISTANCE SEPARATING YOU AND THE VEHICLE BEHIND.

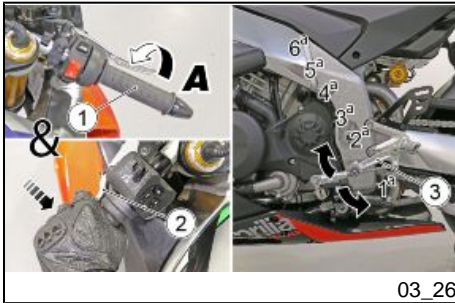

- With the throttle (1) closed (**Pos. A**) and the engine at idle speed, pull the clutch lever (2).
- Push the gearbox lever (3) downward to select the first gear.
- Slowly release the clutch lever while simultaneously accelerating by gently twisting the throttle grip (1) (**Pos.B**).

The vehicle starts moving forward.

CAUTION

DO NOT RELEASE THE CLUTCH TOO QUICKLY OR SUDDENLY, AS THIS COULD CAUSE THE ENGINE TO STALL OR THE VEHICLE TO REAR UP ON THE BACK WHEEL. DO NOT ACCELERATE SUDDENLY WHEN RELEASING THE CLUTCH FOR THE SAME REASON.

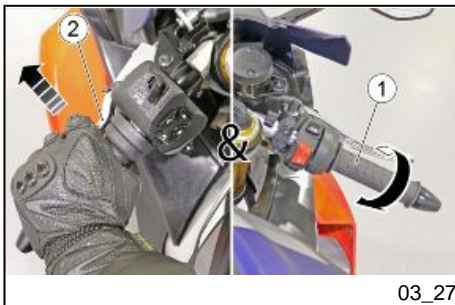

- Ride at moderate speed for the first kilometres/miles to allow the engine to warm up.

NOTE

THE VEHICLE HAS AN RPM LIMITER THAT IS PART OF THE "RIDE-BY-WIRE" INJECTION SYSTEM.

- Increase speed by turning the throttle grip (1) gradually (**Pos. B**), without exceeding the recommended maximum engine speed.



**SELECT THE APPROPRIATE GEAR AND SPEED FOR THE CONDITIONS.
DO NOT ALLOW THE ENGINE SPEED TO DROP EXCESSIVELY.**

- Release the throttle (1) (**Pos. A**), pull the clutch lever (2), lift the gear lever (3), release the clutch (2) and accelerate.
- Repeat the last two operations and engage a higher gear.

NOTE

THE QUICK SHIFT FUNCTION LETS THE RIDER PERFORM UPSHIFTS WITHOUT USING THE CLUTCH.

It is recommended to down-shift from a higher gear to a lower gear:

- When riding downhill and under braking, using engine compression to increase braking power.
- When going uphill, when the engaged gear does not suit the speed (high gear, moderate speed) and the number of engine revs falls.

CAUTION

DOWN-SHIFT ONE GEAR AT A TIME; WHEN SHIFTING TO A LOWER GEAR, DOWN-SHIFTING MORE THAN ONE GEAR AT A TIME COULD OVER-REV THE ENGINE; THAT IS, THE MAXIMUM RPM VALUE PERMITTED FOR THE ENGINE COULD BE EXCEEDED.

NOTE

THE VEHICLE IS EQUIPPED WITH A NON-SLIP CLUTCH CAPABLE OF PREVENTING THE WHEELS FROM LOCKING UP WHEN DOWNSHIFTING. ANY PULSATIONS ON THE LEVER ARE CORRELATED WITH THE CORRECT OPERATION OF THE SYSTEM.

- Release the throttle grip (1) (**Pos. A**).
- If necessary, pull the brake levers gently and reduce speed.
- Pull the clutch lever (2) and push the gear pedal (3) down to select the next lowest gear.

NOTE

THE QUICK SHIFT FUNCTION LETS THE RIDER PERFORM DOWNSHIFTS WITHOUT USING THE CLUTCH IF THE "AQS DOWN" FUNCTION IS ENABLED.

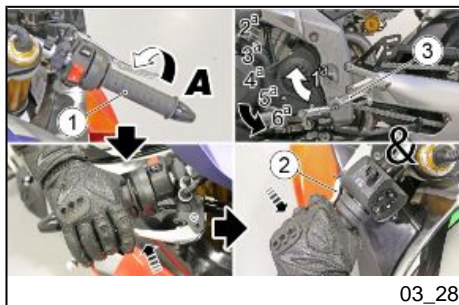

- Release the brake levers when it is operated.
- Release the clutch lever (2).

CAUTION

STOP THE VEHICLE MAINLY USING THE FRONT BRAKE. THE REAR BRAKE MUST ONLY BE USED TO BALANCE THE BRAKING EFFECT, AND ONLY TOGETHER WITH THE FRONT BRAKE.



IF THE MULTI-FUNCTION DIGITAL DISPLAY SHOWS THE COOLANT TEMPERATURE IS HIGHER THAN 115°C (239°F) STOP THE VEHICLE AND LET THE ENGINE RUN AT 3000 rpm FOR ABOUT TWO MINUTES, ALLOWING THE COOLANT TO CIRCULATE REGULARLY IN THE SYSTEM; THEN TURN THE ENGINE STOP SWITCH TO "OFF" AND CHECK THE COOLANT LEVEL.

IF, AFTER CONTROLLING THE COOLANT LEVEL, THE TEMPERATURE INDICATOR KEEPS FLASHING, CONTACT AN Authorised Aprilia Dealer.

DO NOT TURN THE IGNITION KEY TO "KEY OFF", AS THIS WILL STOP THE COOLING FANS REGARDLESS OF THE COOLANT TEMPERATURE, CAUSING THUS THE COOLANT TEMPERATURE RISE FURTHER.

IN MANY CASES THE ENGINE MAY CONTINUE TO PERFORM, BUT WITH REDUCED PERFORMANCE; CONTACT AN Authorised Aprilia Dealer IMMEDIATELY.

IN ORDER TO AVOID CLUTCH OVERHEATING, SHUT THE ENGINE OFF AS SOON AS POSSIBLE ONCE THE VEHICLE HAS STOPPED AND AT THE SAME TIME THE GEAR IS ENGAGED AND THE CLUTCH LEVER OPERATED.



USING JUST THE FRONT OR THE REAR BRAKE ONLY SIGNIFICANTLY REDUCES THE BRAKING FORCE OF THE VEHICLE.

WHEN STOPPING UPHILL, DECELERATE COMPLETELY AND ONLY USE THE BRAKES TO MAINTAIN THE VEHICLE IN THE STOPPED POSITION.

USING THE ENGINE TO KEEP THE MOTORCYCLE STOPPED COULD CAUSE THE CLUTCH TO OVERHEAT. BRAKING CONTINUOUSLY WHEN DRIVING DOWNHILL COULD CAUSE THE BRAKE PADS TO OVERHEAT, WHICH REDUCES BRAKING AND LIMITS BRAKING POWER.

IT IS RECOMMENDED TO USE THE ENGINE COMPRESSION, DOWNSHIFTING AND USING BOTH BRAKES INTERMITTENTLY.

WHEN DRIVING DOWNHILL, NEVER RIDE WITH THE ENGINE TURNED OFF.

WHEN RIDING ON WET OR POOR GRIP SURFACES (SNOW, ICE, MUD, ETC.) MAINTAIN A MODERATE SPEED, AVOIDING SUDDEN BRAKING OR MANOEUVRES THAT COULD CAUSE A LOSS OF TRACTION AND POSSIBLY A CRASH OR ACCIDENT.



Stopping the engine (03_29)

- Release the throttle grip (1), brake gradually and simultaneously downshift to slow down.

Once the speed is reduced, before stopping the vehicle:

- Operate the clutch lever (2) so that engine does not shut off.

When the vehicle is at standstill:

- Put the gear lever in neutral until the letter "N" (neutral) appears on the digital display and the respective indicator lamp lights.
- Release the clutch lever.
- While at a temporary halt, keep at least one of the vehicle brakes held.

CAUTION

WHENEVER POSSIBLE, AVOID ROUGH BRAKING, SUDDEN DECELERATION AND BRAKING IN EXCESS.

Parking

It is very important to select an adequate parking spot, in compliance with road signals and the guidelines described below.

CAUTION

PARK ON SAFE AND LEVEL GROUND TO PREVENT THE VEHICLE FROM FALLING.

DO NOT LEAN THE VEHICLE AGAINST A WALL OR LAY IT ON THE GROUND.

ENSURE THAT THE VEHICLE AND, IN PARTICULAR, PARTS OF THE VEHICLE WHICH MAY BECOME HOT (ENGINE, OIL RADIATOR AND LINES, EXHAUST SYSTEM, BRAKE DISCS) ARE NOT A HAZARD TO PERSONS OR CHILDREN. DO NOT LEAVE YOUR VEHICLE UNATTENDED WITH THE ENGINE ON OR THE KEY IN THE IGNITION SWITCH.

CAUTION

IF THE VEHICLE FALLS OR IS ON A STEEP INCLINE FUEL CAN LEAK.

FUEL USED TO DRIVE INTERNAL COMBUSTION ENGINES IS HIGHLY FLAMMABLE AND CAN BECOME EXPLOSIVE UNDER CERTAIN CONDITIONS.



DO NOT REST THE RIDER OR PASSENGER WEIGHT ON THE SIDE STAND.

Catalytic silencer

The vehicle has a silencer with a "platinum - palladium - rhodium three-way" metal catalytic converter.

This device oxidises the CO (carbon monoxide) producing carbon dioxide, and the UHC (unburned hydrocarbons) producing water vapour and reduces NOx (nitrogen oxide) producing oxygen and nitrogen present in the exhaust fumes.



DO NOT PARK THE VEHICLE NEAR DRY BRUSHWOOD OR IN PLACES EASILY ACCESSIBLE BY CHILDREN BECAUSE THE CATALYTIC CONVERTER REACHES HIGH TEMPERATURES DURING VEHICLE OPERATION; FOR THIS REASON, PAY UTMOST ATTENTION AND DO NOT TOUCH IT UNTIL IT HAS COMPLETELY COOLED DOWN.



DO NOT USE LEADED PETROL AS IT CAUSES IRREPARABLE DAMAGE TO THE CATALYTIC CONVERTER.

Vehicle owners are warned that the law may prohibit the following:

- the removal of any device or element belonging to a new vehicle or any other action by anyone leading to render it non-operating, if not for maintenance, repair or replacement reasons, in order to control noise emission before the sale or delivery of the vehicle to the ultimate buyer or while it is used;
- using the vehicle after that device or element has been removed or rendered non-operating.

Check the muffler/exhaust silencer and the silencer pipes, make sure there are no signs of rust or holes and that the exhaust system works properly.

If you not an increase in exhaust noise, take your vehicle to an Authorised **Aprilia** Dealer at once.



THIS MOTORCYCLE IS FITTED WITH A VALVE IN THE EXHAUST SYSTEM CONTROLLED BY THE ELECTRONIC CONTROL UNIT. WHEN THE MOTORCYCLE IS STOPPED AND IS IN NEUTRAL, THIS VALVE CLOSSES IN ORDER TO LIMIT THE EXHAUST SILENCER NOISE.

TAMPERING WITH THE EXHAUST SYSTEM AND/OR THIS VALVE IS STRICTLY PROHIBITED.

Stand (03_30)

If it is necessary to extend the side stand for any reason (e.g. after moving the vehicle), proceed as follows:

- Select an appropriate parking spot.
- Grip the left grip (1) and keep your right hand on the upper rear part of the vehicle (2).
- Lower the side stand with your right foot, fully extending it.
- Lean the motorcycle until the stand touches the ground.
- Turn the handlebar completely to the left.



MAKE SURE THAT THE GROUND ON WHICH THE MOTORCYCLE IS PARKED IS FIRM, EVEN AND FREE OF OBSTACLES.

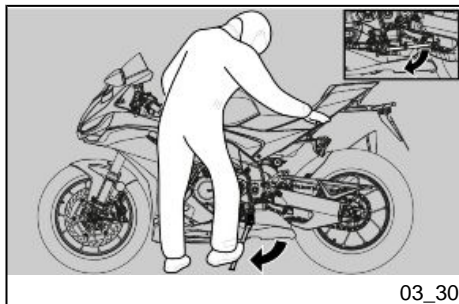

Suggestion to prevent theft

CAUTION

WHEN USING A DISC LOCKING DEVICE, PAY UTMOST ATTENTION TO REMOVE IT BEFORE RIDING. FAILURE TO OBSERVE THIS WARNING MAY CAUSE SERIOUS DAMAGE TO THE BRAKING SYSTEM AND ACCIDENTS WITH CONSEQUENT PHYSICAL INJURIES OR EVEN DEATH.

NEVER leave the ignition key in the lock and always use the steering lock. Park the vehicle in a safe place such as a garage or a place with guards. Whenever possible, use an additional anti-theft device. Make sure all vehicle documents are in order and the road tax paid. Write down your personal details and telephone number on this page to help identifying the owner in case of vehicle retrieval after a theft.

LAST NAME:

NAME:

ADDRESS:

TELEPHONE NO.:

WARNING

IN MANY CASES, STOLEN VEHICLES CAN BE IDENTIFIED BY DATA IN THE USE / MAINTENANCE BOOKLET.

Safe driving

Some simple tips are provided below that will enable you to use your motorcycle on a daily basis in greater safety and peace of mind. Your mechanical knowledge and ability are the foundation for safe driving. We recommend trying out the motorcycle in traffic-free zones to familiarise with it.

1. Before riding off, remember to put the helmet on and fasten it correctly.

2. Slow down and drive carefully over bumpy roads.
3. After driving over a long stretch of wet road without using the brakes, braking will not be as efficient the first time/s you use them again. When driving under conditions like this, you should brake periodically.
4. Although the vehicle is equipped with an ABS system, pay attention when braking on wet surfaces, on dirt or on a slippery road surface.
5. Do not start off by getting on the vehicle while it is standing on its stand.
6. When riding on roads covered with sand, mud, snow mixed with salt, etc. We recommend cleaning the brake discs frequently with a non-corrosive detergent in order to prevent corrosive particles from building up in the holes, which may cause early brake pad wear.

CAUTION

ALWAYS RIDE WITHIN YOUR LIMITS. RIDING UNDER THE INFLUENCE OF ALCOHOL OR OTHER DRUGS AND CERTAIN MEDICINES IS EXTREMELY DANGEROUS.

CAUTION

ANY ELABORATION THAT MODIFIES THE VEHICLE'S PERFORMANCES, SUCH AS TAMPERING WITH ORIGINAL STRUCTURAL PARTS IS STRICTLY FORBIDDEN BY LAW, AND RENDERS THE MOTORCYCLE NO LONGER CONFORMING TO THE APPROVED TYPE AND DANGEROUS FOR RIDING.

CAUTION

DO NOT ADJUST THE MIRRORS WHILE DRIVING. THIS COULD CAUSE YOU TO LOOSE CONTROL OF THE MOTORCYCLE.

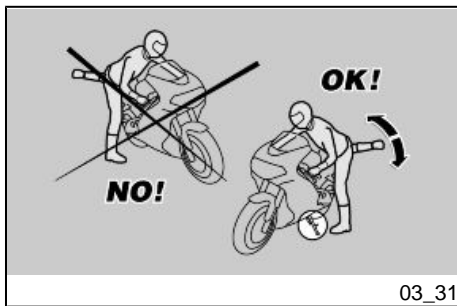

03_31

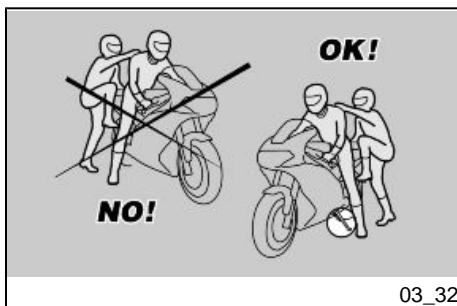

03_32

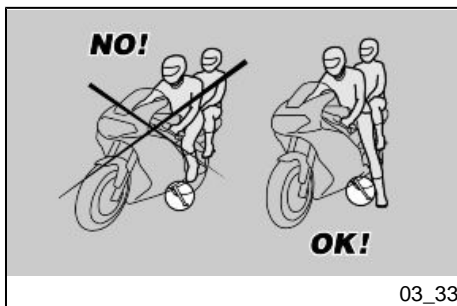

03_33

Basic safety rules (03_31, 03_32, 03_33, 03_34, 03_35)

The following recommendations should receive your maximum attention, because they are provided to increase your safety, and decrease damage to people, things and vehicles, in the case of a fall of the rider or passenger from the vehicle and/or from the fall or overturning of the vehicle.

Mounting and dismounting the vehicle should always be performed with total freedom of movement and with the hands free of all objects. (i.e.- objects, helmet, gloves, or glasses).

Mount and dismount only on the left side of the vehicle, and only with the side stand lowered.

The stand is designed to support the weight of the vehicle and a small additional weight, which does not include the rider and passenger.

Mounting into driving position, with the side stand in place, is permitted only to prevent the possibility of the vehicle falling or overturn, and does not indicate the possibility for the rider and passenger's weight to be placed on the side stand.

During mounting and dismounting the vehicle's weight can cause a loss of balance, with consequent loss of equilibrium and the possibility of falling or overturning.

CAUTION

THE RIDER SHOULD ALWAYS BE THE FIRST TO MOUNT AND THE LAST TO DISMOUNT FROM THE VEHICLE, AND SHOULD CONTROL THE STABILITY AND



EQUILIBRIUM OF THE VEHICLE WHILE THE PASSENGER IS MOUNTING AND DISMOUNTING

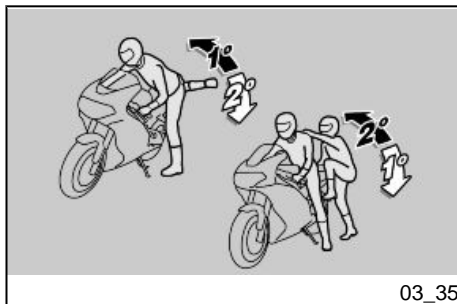

In any case, the passenger should mount and dismount the vehicle using caution to avoid causing the vehicle or the rider to lose balance.

CAUTION

THE RIDER TO INSTRUCT THE PASSENGER ABOUT THE PROPER WAY TO MOUNT AND DISMOUNT FROM THE VEHICLE.

THE VEHICLE INCLUDES PASSENGER FOOTRESTS WHICH SHOULD BE USED DURING MOUNTING AND DISMOUNTING. THE PASSENGER SHOULD ALWAYS USE THE LEFT FOOTREST FOR MOUNTING AND DISMOUNTING FROM THE VEHICLE.

DO NOT DISMOUNT OR EVEN ATTEMPT TO DISMOUNT BY JUMPING OR STRETCHING OUT YOUR LEG IN ORDER TO TOUCH THE GROUND. IN BOTH CASES THE STABILITY AND EQUILIBRIUM OF THE VEHICLE COULD BE COMPROMISED.

CAUTION

BAGGAGE OR OBJECTS ATTACHED TO THE REAR PART OF THE VEHICLE CAN CREATE AN OBSTACLE DURING MOUNTING AND DISMOUNTING FROM THE VEHICLE.

IN ALL CASES, THINK AHEAD AND MOVE YOUR RIGHT LEG CAREFULLY, AS IT WILL HAVE TO AVOID AND CLEAR THE REAR PART OF THE VEHICLE (INCLUDING BAGGAGE AND THE TAIL FAIRING) WITHOUT CAUSING LOSS OF BALANCE.

MOUNTING

- Grip the handlebar properly and mount the vehicle without placing your weight upon the side stand.

CAUTION

IN THE CASE THAT YOU ARE NOT ABLE TO REST BOTH FEET ON THE GROUND, PUT THE RIGHT FOOT ON THE GROUND, (IN THE CASE OF A LOSS OF BALANCE THE LEFT SIDE IS "PROTECTED" BY THE SIDE STAND) AND KEEP YOUR LEFT FOOT READY TO BE POSITIONED.

- Place both feet on the ground and straighten the vehicle into the driving position, always maintaining its equilibrium.

CAUTION

THE RIDER SHOULD NOT OPEN OR TRY TO OPEN THE PASSENGER FOOTRESTS FROM THE RIDER'S SEAT, AS IT COULD COMPROMISE THE STABILITY AND EQUILIBRIUM OF THE VEHICLE.

- Have the passenger open the two passenger foot pegs.
- Show the passenger how to mount the vehicle.
- Use your left foot to push on the side stand and make it fully return to its position.

DISMOUNTING

- Select an appropriate parking spot.
- Stop the vehicle.
- Switch off the engine.



MAKE SURE THAT THE GROUND ON WHICH THE MOTORCYCLE IS PARKED IS FIRM, EVEN AND FREE OF OBSTACLES.

- Use the heel of your left foot to completely open the side stand.

CAUTION

IN THE CASE THAT YOU ARE NOT ABLE TO REST BOTH FEET ON THE GROUND, PUT THE RIGHT FOOT ON THE GROUND, (IN THE CASE OF A LOSS OF BALANCE THE LEFT SIDE IS "PROTECTED" BY THE SIDE STAND) AND KEEP YOUR LEFT FOOT READY TO BE POSITIONED.

- Place both feet on the ground and keep the vehicle balanced in the driving position.
- Instruct the passenger on how to get down from the vehicle.



RISK OF FALLING OR OVERTURNING.

**MAKE SURE THAT THE PASSENGER HAS DISMOUNTED FROM THE VEHICLE.
DO NOT PLACE YOUR WEIGHT UPON THE SIDE STAND.**

- Lean the motorcycle until the stand touches the ground.
- Correctly grip the handlebar, and dismount from the vehicle.
- Turn the handlebar completely to the left.
- Place the passenger footrest in its place.

CAUTION

MAKE SURE THE VEHICLE IS STABLE.

RSV4 1100



Chap. 04 Maintenance

Foreword

WARNING

THE ELECTRONIC CONTROL SYSTEM OF THIS VEHICLE IDENTIFIES FAULTS IN REAL TIME AND STORES THEM IN ITS MEMORY FOR SUBSEQUENT READING WITH THE DIAGNOSTIC SYSTEM USED BY Authorised Aprilia Dealers.

Engine oil level check (04_01, 04_02)

Check the engine oil level frequently.

NOTE

HALVE THE SERVICE INTERVALS INDICATED IF THE VEHICLE IS USED IN PARTICULARLY RAINY OR DUSTY CONDITIONS, ON POOR ROADS OR FOR HIGH PERFORMANCE RIDING.



THE OIL LEVEL MUST BE CHECKED WHEN THE ENGINE IS WARM.

CAUTION

DO NOT LET THE ENGINE IDLE WITH THE VEHICLE AT A STANDSTILL TO WARM UP THE ENGINE AND OBTAIN THE OPERATING TEMPERATURE OF ENGINE OIL.

PREFERABLY CHECK THE OIL AFTER A JOURNEY OF AFTER TRAVELLING APPROXIMATELY 15 Km (10 miles) IN EXTRA-URBAN CONDITIONS (ENOUGH TO WARM UP THE ENGINE OIL TO OPERATING TEMPERATURE).

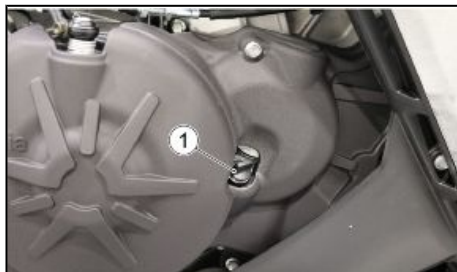

04_01

- Shut off the engine and wait a few seconds
- Keep the vehicle upright with both wheels on the earth
- Ensure that you are on a flat surface
- Unscrew the engine oil level dipstick (1)

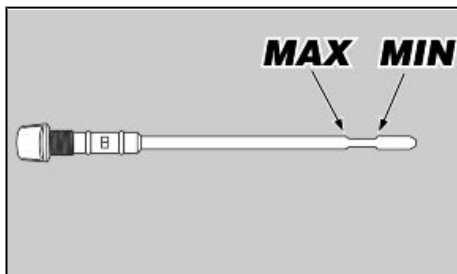

04_02

- Clean the engine oil level dipstick (1) and put it back in **without screwing it in**
- Remove it again and check the engine oil level
- The level is correct if it reaches the "**MAX**" level approximately. Otherwise top off the engine oil

CAUTION

THE OIL LEVEL MUST NEVER DROP BELOW THE MINIMUM MARKING OR EXCEED THE MAXIMUM MARKING; AN OIL LEVEL NOT WITHIN THE MINIMUM AND MAXIMUM MARKINGS MAY CAUSE SEVERE ENGINE DAMAGE

Engine oil top-up (04_03)

If the engine oil needs to be topped up, proceed as follows:

- Unscrew and remove the cap.

CAUTION

ONLY USE THE ENGINE OIL TYPE INDICATED IN THE RECOMMENDED FLUIDS AND LUBRICANTS TABLE.



04_03

- Pour in the necessary quantity of engine oil to reach the correct level.

CAUTION

DO NOT ADD ADDITIVES OR ANY OTHER SUBSTANCES TO THE OIL. WHEN USING A FUNNEL OR ANY OTHER ELEMENT, MAKE SURE IT IS PERFECTLY CLEAN.

Engine oil change

CAUTION

THE ENGINE OIL MAY ONLY BE CHECKED AND CHANGED BY AN Authorised Aprilia Dealer

Engine oil filter replacement

CAUTION

THE ENGINE OIL FILTER MAY ONLY BE CHECKED AND CHANGED BY AN Authorised Aprilia Dealer

Tyres

This vehicle is fitted with tubeless tyres (without inner tubes).

CAUTION

CHECK TYRE INFLATION PRESSURE REGULARLY AT AMBIENT TEMPERATURE. THE MEASUREMENT MAY BE INCORRECT IF TYRES ARE WARM. CHECK TYRE PRESSURE MAINLY BEFORE AND AFTER A LONG TRIP. AN OVER-INFLATED TYRE WILL PROVIDE A HARSH RIDE AS SURFACE UNEVEN-

NESS IS NOT CUSHIONED AND IS SENT TO THE HANDLEBAR, THUS REDUCING GRIP AND ROAD HOLDING SPECIALLY WHEN CORNERING.

ON THE OTHER HAND, AN UNDER-INFLATED TYRE CAUSES THE CONTACT PATCH TO INCLUDE A LARGER PORTION OF THE TYRE SIDE WALLS. IF SO, THE TYRE MIGHT SLIP ON OR GET DETACHED FROM THE WHEEL RIM, RESULTING IN LOSS OF CONTROL OVER THE VEHICLE.

EVENTUALLY THE VEHICLE MIGHT SKID IN A BEND.

CHECK THE SURFACE CONDITION AND WEAR BECAUSE POOR TYRE CONDITION COULD COMPROMISE GRIP AND HANDLING OF THE VEHICLE.

SOME TYRE TYPES APPROVED FOR THIS VEHICLE FEATURE WEAR INDICATORS.

THERE ARE SEVERAL TYPES OF WEAR INDICATORS. CONSULT YOUR DEALER ON METHODS TO CHECK FOR WEAR.

CARRY OUT A VISUAL INSPECTION FOR TYRE WEAR AND TEAR, REPLACE TYRES WHEN WORN.

WHEN TYRES ARE OLD, THE MATERIAL MAY HARDEN AND NOT PROVIDE ADEQUATE ROAD HOLDING, EVEN IF TYRES ARE STILL WITHIN THE WEAR LIMIT. REPLACE TYRES IF THIS OCCURS. REPLACE THE TYRE IF IT IS WORN OR IF THERE IS A PUNCTURE LARGER THAN 5 mm (0.197 in) IN THE TREAD AREA.

WHEEL MUST BE BALANCED AFTER A TYRE IS MENDED.

USE ONLY TYRE SIZES INDICATED BY THE MANUFACTURER. DO NOT FIT TYRES WITH INNER TUBES ON RIMS FOR TUBELESS TYRES OR VICE VERSA. CHECK THAT THE INFLATION VALVES HAVE THEIR CAPS FITTED TO AVOID UNEXPECTED FLAT TYRES.

REPLACEMENT, REPAIR, MAINTENANCE AND BALANCING OPERATIONS ARE HIGHLY IMPORTANT AND SO THEY SHOULD BE CARRIED OUT USING THE SPECIFIC TOOLS AND WITH THE ADEQUATE KNOWLEDGE. HAVE YOUR TYRES AND WHEELS SERVICED AT AN AUTHORISED DEALER OR A SPECIALISED TYRE WORKSHOP.

NEW TYRES MAY BE COATED WITH AN OILY FILM: RIDE WITH CAUTION DURING THE FIRST KILOMETRES. DO NOT APPLY UNSUITABLE LIQUIDS ON TYRES.

Minimum tread depth:

front and rear: 2 mm (0.079 in) (USA 3 mm) (USA - 0.118 in), and never less than specified by applicable legislation in the country in which the vehicle is used.

Spark plug dismantlement

CAUTION

THE SPARK PLUGS MAY ONLY BE CHECKED, CLEANED AND CHANGED BY AN Authorised Aprilia Dealer

Removing the air filter

CAUTION

THE AIR FILTER MAY ONLY BE CHECKED AND CHANGED BY AN Authorised Aprilia Dealer

Cooling fluid level

Do not use the vehicle if the coolant level is below the minimum marking.

CAUTION

COOLANT IS TOXIC IF INGESTED; CONTACT WITH YOUR EYES OR SKIN MAY CAUSE IRRITATION. IF THE FLUID GETS IN CONTACT WITH THE EYES OR SKIN, RINSE REPEATEDLY WITH PLENTY OF WATER AND SEEK MEDICAL ADVICE. IF SWALLOWED, INDUCE VOMITING, RINSE MOUTH AND THROAT WITH PLENTY OF WATER AND SEEK MEDICAL ADVICE IMMEDIATELY.

Coolant solution is 50% water and 50% antifreeze fluid.

This mixture is suitable for the majority of operating temperatures and offers adequate corrosion protection.

It is advisable to use the same mixture even in hot weather as this minimises loss due to evaporation and the need of frequent top-ups.

This reduces the quantity of salt deposits left in the radiator by evaporating water to ensure constant cooling system performance.

If the external temperature drops below 0°C (32°F), check the cooling circuit frequently and, if necessary, increase the concentration of antifreeze (up to a maximum of 60%).

Use distilled water in the coolant mixture to avoid damaging the engine.

CAUTION

NEVER UNDO THE RADIATOR CAP WHEN THE ENGINE IS WARM, AS THE COOLANT IS PRESSURISED AND VERY HOT. CONTACT WITH SKIN OR CLOTHES MAY CAUSE SEVERE BURNS AND/OR INJURIES.

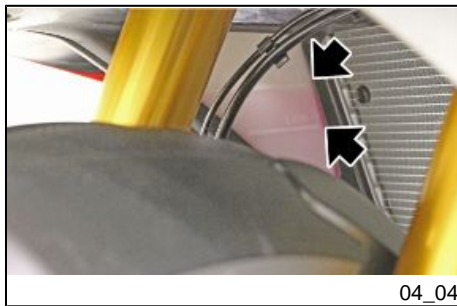

Coolant check (04_04)

- Shut off the engine and wait until it cools off.
- Keep the vehicle upright with both wheels on a flat surface.
- Looking from the left side of the vehicle through the specific opening on the internal right fairing, ensure that the liquid level in the expansion tank is between the "**FULL**" (maximum) and "**LOW**" (minimum) marks.

WARNING

CARRY OUT THE CHECK AND TOP UP THE REFRIGERANT LIQUID WITH THE ENGINE SWITCHED OFF AND COLD.

Coolant top-up

NOTE

FOR REMOVING, CHECKING AND CHANGING THE COOLANT CONTACT AN Official Aprilia Dealer

Checking the brake oil level

Checking brake fluid

- Rest the vehicle on its stand.
- For the front brake, turn the handlebar all the way to the right.
- For the rear brake, keep the vehicle upright so that the fluid in the reservoir is at the same level as the plug.
- Make sure that the fluid level in the reservoir is above the "**MIN**" reference mark:

MIN = minimum level

MAX = maximum level

If the fluid does not reach at least the "**MIN**" reference mark:

- Check brake pads and discs for wear.
- If the pads and/or the disc do not need replacing, top-up the fluid.

Braking system fluid top up (04_05, 04_06)



RISK OF BRAKE FLUID SPILLING. DO NOT OPERATE THE BRAKE LEVER IF THE BRAKE FLUID RESERVOIR CAP IS LOOSE OR HAS BEEN REMOVED.

CAUTION



AVOID PROLONGED AIR EXPOSURE OF THE BRAKE FLUID. BRAKE FLUID IS HYGROSCOPIC AND ABSORBS MOISTURE WHEN IN CONTACT WITH AIR. LEAVE THE BRAKE FLUID RESERVOIR OPEN ONLY FOR THE TIME NEEDED TO COMPLETE THE TOPPING-UP PROCEDURE.



TO AVOID SPILLING FLUID WHILE TOPPING UP, KEEP THE LEVEL OF THE FLUID IN THE RESERVOIR PARALLEL WITH THE EDGE OF THE RESERVOIR ITSELF (IN HORIZONTAL POSITION). DO NOT ADD ADDITIVES OR OTHER SUBSTANCES TO THE FLUID. FUNNELS OR ANY OTHER IMPLEMENTS USED MUST BE PERFECTLY CLEAN.



BRAKE FLUID IS HIGHLY CORROSIVE. AVOID CONTACT WITH THE SKIN, EYES AND PARTS OF THE MOTORCYCLE.

WHEN TOPPING UP, PROTECT PARTS OF THE MOTORCYCLE IN THE VICINITY OF THE RESERVOIR WITH ABSORBENT MATERIAL.

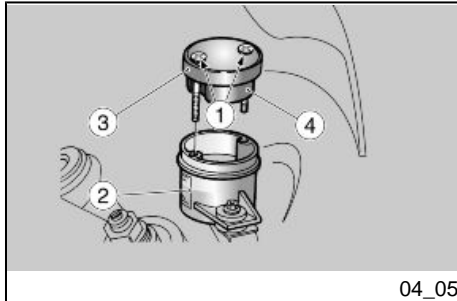

Recommended products

DOT 4 brake fluid

Synthetic brake fluid.

SAE J 1703; FMVSS 116; ISO 4925; CUNA NC 956 DOT4

Front braking system

- Use a short cross-head screwdriver to undo the screws (1) of the front braking system fluid reservoir (2).
- Lift and remove the cover (3), complete with screws (1) and the gasket (4).
- Top up the reservoir (2) with recommended brake fluid to above the minimum level marking "**MIN**".

CAUTION



ONLY FILL TO THE "MAX" LEVEL AFTER FITTING NEW BRAKE PADS. DO NOT FILL TO THE "MAX" LEVEL WITH WORN PADS, AS THIS WILL CAUSE FLUID TO ESCAPE WHEN REPLACING BRAKE PADS.

CHECK BRAKING EFFICIENCY.

IF THE DEAD ZONE OF THE BRAKE PEDAL OR BRAKE LEVER IS TOO LONG, OR IN CASE OF FLUID LOSS, IT MAY BE NECESSARY TO BLEED THE AIR TRAPPED IN THE SYSTEM.

HAVE THIS PROCEDURE PERFORMED BY AN Authorised Aprilia Dealer.

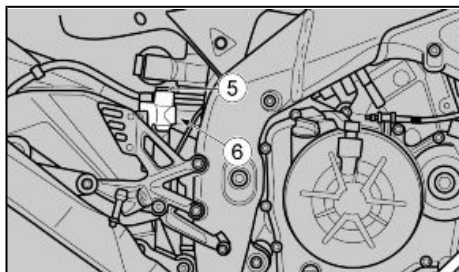

04_06

Rear braking system

- Unscrew and remove the upper nut (5) from the rear brake pump.
- Top up the reservoir with the recommended brake fluid to reach the correct level on the sight glass (6).

CAUTION



ONLY FILL TO THE "MAX" LEVEL AFTER FITTING NEW BRAKE PADS. DO NOT FILL TO THE "MAX" LEVEL WITH WORN PADS, AS THIS WILL CAUSE FLUID TO ESCAPE WHEN REPLACING BRAKE PADS.

CHECK BRAKING EFFICIENCY.

IF THE DEAD ZONE OF THE BRAKE PEDAL OR BRAKE LEVER IS TOO LONG, OR IN CASE OF FLUID LOSS, IT MAY BE NECESSARY TO BLEED THE AIR TRAPPED IN THE SYSTEM.

HAVE THIS PROCEDURE PERFORMED BY AN Authorised Aprilia Dealer.

Battery

NOTE

THIS VEHICLE IS EQUIPPED WITH A LITHIUM BATTERY.

ONLY USE THE VEHICLE WITH A TEMPERATURE RANGE FROM 0°C TO +40°C (32°F TO +104°F).

IN CASE OF CONTINUED USE AT TEMPERATURES NOT WITHIN THIS RANGE, INSTALL A YUASA YTZ10S LEAD BATTERY.

IF THE VEHICLE FAILS TO START AT TEMPERATURES BELOW 0°C (32°F), TRY AGAIN REPEATEDLY, TO WARM THE BATTERY UP TO OPERATING TEMPERATURE, UNTIL THE ENGINE STARTS.

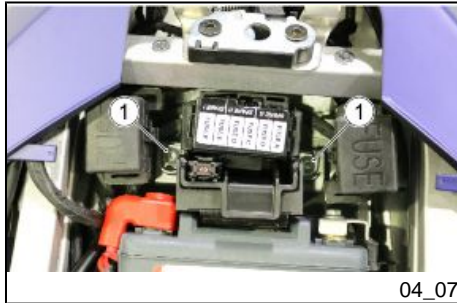

04_07

Battery removal (04_07, 04_08)

- Ensure that the ignition switch is turned to "OFF".
- Remove the rider saddle.
- Remove the two screws (1).



04_08

- Turn the battery so that its poles are accessible.
- Unscrew and remove the screw (2) of the negative terminal (-).
- Move the negative lead (3) aside.
- Move the positive terminal (+) protective rubber cap .
- Unscrew and remove the screw (4) of the positive terminal (+).
- Move the positive lead (5) aside.



TAKE UTMOST CARE AND DO NOT MAKE CONTACT BETWEEN THE BATTERY TERMINALS AND ANY METALLIC OBJECT IN ORDER TO PREVENT THE RISK OF SHORT CIRCUIT.

- Grip the battery (6) firmly and remove it from its seat, lifting it.
- Put the battery away on a level surface, in a cool and dry place.
- Refit the rider saddle.

Use of a new battery (04_09, 04_10, 04_11)



CHECK THAT THE CABLE TERMINALS AND BATTERY LEADS ARE:

- IN GOOD CONDITION (NOT CORRODED OR COVERED BY DEPOSITS);
- COVERED BY NEUTRAL GREASE OR PETROLEUM JELLY.

CAUTION

UPON REFITTING, CONNECT THE LEAD TO THE POSITIVE TERMINAL (+) FIRST AND AFTERWARDS THE LEAD TO THE NEGATIVE TERMINAL (-).



- If the saddle had been refitted, remove it.
- Install the battery (6) in its seat.
- Position the positive cable (5) correctly, and fasten it to the positive terminal (+), tightening the screw (4).

The positive cable (5) must be positioned to the side of the battery (6).

- Position the rubber protective cap on the positive terminal (+).
- Position the negative cable (3) correctly, and fasten it to the negative terminal (-), tightening the screw (2).

The negative cable (3) must be positioned to the side of the battery (6).

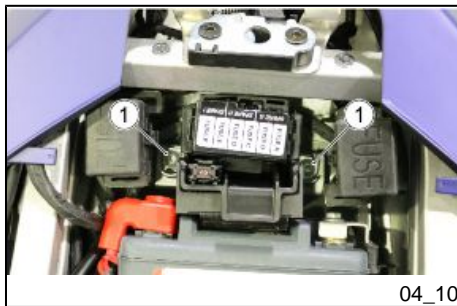

- Position the fuse holder complete with spacer and fix it with the two screws (1).

WARNING

THIS MOTORCYCLE IS EQUIPPED WITH A BATTERY THAT REQUIRES NO MAINTENANCE OTHER THAN PERIODICALLY CHECKING STATE OF CHARGE.

NOTE

IN ORDER TO INSTALL AND USE A NEW CONVENTIONAL LEAD BATTERY, THE SPACER (7) INSTALLED ON THE SECONDARY FUSE HOLDER MUST BE REMOVED.

ACT ON THE LOCKING TABS (8) TO REMOVE THE SPACER (7).

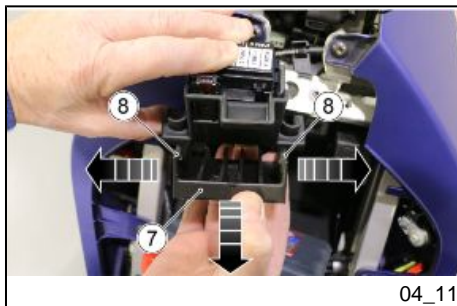

Charging the battery

The battery may be charged with the battery itself in its mounting on the vehicle and connected to the electrical system of the vehicle. The battery may also be charged with the battery removed from the vehicle and disconnected from the electrical system.

To charge the battery:

- Set the battery charger for the recharge type indicated.
- Connect the battery to a battery charger of a suitable type for the battery itself.

CAUTION



WHEN RECHARGING OR USING THE BATTERY, BE CAREFUL TO HAVE THE ROOM ADEQUATELY AIRED. DO NOT BREATHE GASES RELEASED WHEN THE BATTERY IS RECHARGING.

The lithium battery may also be charged with a conventional charger for 12V lead batteries (without automatic desulfation function or pulse charging function), with the settings and parameters described as follows:

Normal recharge

- Electric current: 2,0 A
- Time: 2 hours

Quick charge

- Electric current: 8 A
- Time: 0,5 hours

WARNING

THE CHARGE VOLTAGE MUST NEVER EXCEED 15V.

NOTE

AFTER CHARGING, WAIT ONE OR TWO HOURS BEFORE CHECKING THE VOLTAGE. IF THE VOLTAGE IS BELOW 12.4V, ADDITIONAL CHARGING IS NECESSARY.

SETTINGS AND PARAMETERS FOR CHARGING LEAD BATTERIES:**Normal recharge**

- Electric current: 1,0 A
- Time: 8-10 hours

Quick charge

- Electric current: 10 A
- Time: 1 hour

Long periods of inactivity

IF THE VEHICLE IS INACTIVE FOR MORE THAN FIFTEEN DAYS, DISCONNECT THE 30A FUSE TO PREVENT THE BATTERY FROM DETERIORATING DUE TO THE CONSUMPTION OF CURRENT BY THE MULTI-FUNCTION COMPUTER.

CAUTION

REMOVING THE 30A FUSE WILL RESET THE DIGITAL CLOCK, TRIP INFORMATION AND CHRONOMETER TIMES.

If the vehicle is inactive longer than fifteen days, the battery needs to be recharged.

- Remove the battery.

In winter or when the vehicle is out of use for prolonged periods, check charge level frequently (about once a month) to prevent deterioration.

- Recharge it fully with an ordinary charge.

If the battery is still on the vehicle, disconnect the cables from the terminals.

Fuses (04_12, 04_13, 04_14, 04_15, 04_16, 04_17, 04_18)

It is necessary to check the fuses whenever an electrical component fails to operate or malfunctions or when the engine does not start.

Check the auxiliary 15A fuses first, then the main 30A fuse.

CAUTION



DO NOT ATTEMPT TO REPAIR FAULTY FUSES.

NEVER USE A FUSE THAT IS DIFFERENT THAN WHAT IS SPECIFIED TO PREVENT DAMAGES TO THE ELECTRICAL SYSTEM OR SHORT CIRCUITS, AND THE RISK OF FIRE.

CAUTION

A FUSE THAT BLOWS FREQUENTLY MAY INDICATE A SHORT CIRCUIT OR OVERLOAD. CONTACT AN authorised aprilia Dealer.

To check:

- To avoid an accidental short-circuit, place the power switch to "OFF".



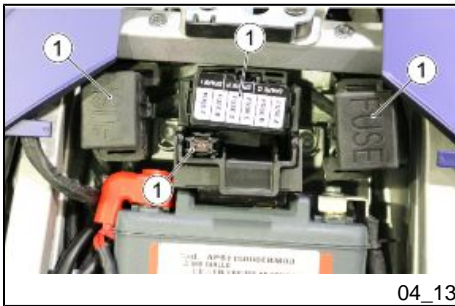

- Remove the rider saddle.
- Open the covers of the secondary fuse boxes (1).

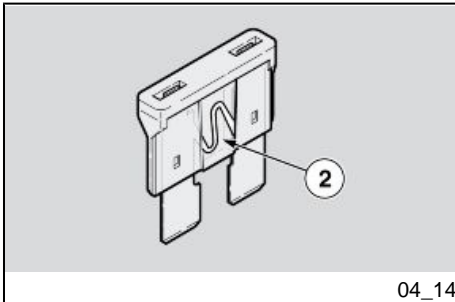

- Take out one fuse at a time and check whether the filament (2) is broken.
- Before replacing the fuse, find and solve, if possible, the reason that caused the problem.
- If the fuse is damaged, replace it with one of the same current rating.

NOTE

IF THE SPARE FUSE IS USED, REPLACE WITH ONE OF THE SAME TYPE IN THE CORRESPONDING FITTING.

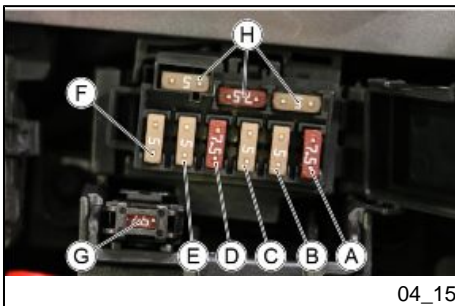

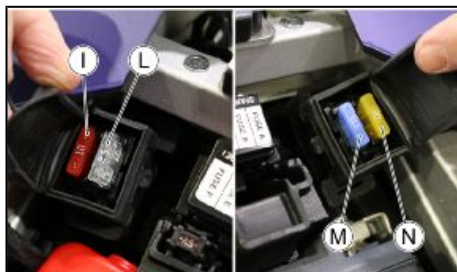

04_16

AUXILIARY FUSES DISTRIBUTION

A) 7.5A fuse	Rear position, horn, licence plate light
B) 5A fuse	Instrument panel power supply, turn indicators, OBD power supply
C) 5A fuse	Positive key-on power for ECU, positive key-on power for ABS, positive key-on power for the instrument panel, positive key-on power for the right hand handlebar control set, main start relay coil, positive key-on power for inertial sensor platform
D) 7.5A fuse	ECU permanent positive lead
E) 5A fuse	Positive key-on power for AMP, positive key-on power for OBD, positive key-on power for USB,

	positive key-on power for the timer fitting,
F) 5A fuse	Positive key-on power for headlamp (load)
G) 7.5A fuse	Positive key-on power for smart EC
H) spare fuses 5 A (2) - 7.5 A	
I) 10A fuse	ABS solenoid valves
L) 25A fuse	ABS motor pump
M) fuse of 15A	Fan power feed
N) fuse of 20A	Fan relay power supply, ECU power supply, fuel pump relay power supply, rear and front lambda power supply, injector power supply, coil power supply, secondary air valve power supply

Auxiliary fuses are placed on the rear part of the motorcycle, under the rider saddle.

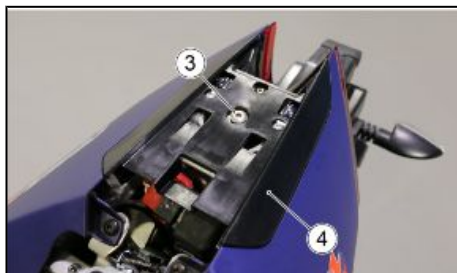

04_17

- To check and replace the main fuse, remove the screw (3) that fastens the cover (4).

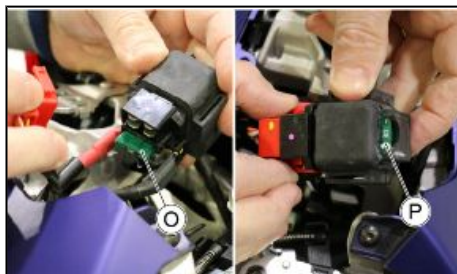

04_18

- Disconnect the main relay holder from the supports and remove the protection cover to gain access to the main fuse (O).
- On the main fuse holder there is a spare fuse (P)

LOCATION OF THE MAIN FUSE

O) 30A fuse

Battery charging, all vehicle utilities

P) spare fuse 30 A

The main fuse is located on the rear part of the motorcycle, under the tail fairing/ passenger saddle.

CAUTION

REMOVING THE 30A FUSE WILL RESET THE: DIGITAL CLOCK, TRIP INFORMATION AND CHRONOMETER TIMES.

Lamps**NOTE**

WHEN THE REAR WHEEL EXCEEDS THE SPEED OF 1 km/h (0.62 mph) (EVEN WITH THE ENGINE OFF, AND THE KEY SET TO ON), THE HEADLIGHTS WILL TURN ON AND WILL REMAIN ON FOR 30 SECONDS (FROM THE TIME IN WHICH THE REAR WHEEL STOPS MOVING).

Front light group (04_19, 04_20)

The headlamp unit uses LED light sources only, and consists of the following modules:

- two low beam headlight modules (1);
- one high beam headlight module (2);
- two DRL modules (3);
- two turn indicator modules (4);
- two bending light modules (to assist rider in bends) (5).



04_19

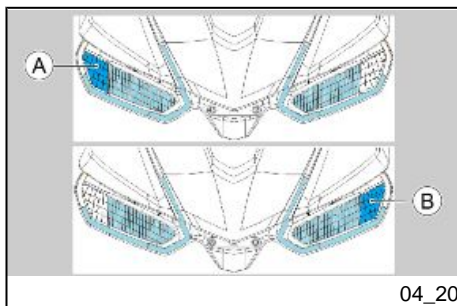

04_20

The bending lights are only activated if the low beam headlights are on and once the vehicle reaches a lean angle of at least 25°.

- When leaning into a left hand bend, the left hand LED bending assist light illuminates (A).
- When leaning into a right hand bend, the right hand LED bending assist light illuminates (A).

CAUTION

IN THE EVENT OF A MALFUNCTION OF THE HEADLAMP UNIT, CONTACT AN Official Aprilia Dealer.

Headlight adjustment (04_21, 04_22, 04_23, 04_24)

NOTE

IN COMPLIANCE WITH LOCAL LEGISLATION, SPECIFIC PROCEDURES MUST BE FOLLOWED WHEN ALIGNING THE LIGHTS.

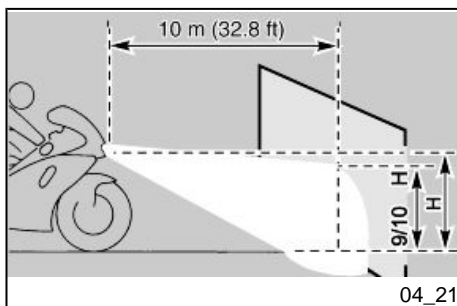

04_21

To quickly check if the headlamp is aimed correctly, place the vehicle on a level surface 10 m (32.8 ft) from a vertical wall. Turn on the low beam light, sit on the vehicle and check that the light beam projected to the wall is a little below the horizontal straight line of the headlight (about 9/10 of the total height).



04_22



04_23



04_24

To carry out vertical adjustment of the light beam:

(LOW BEAM HEADLIGHTS)

- Operating from the rear side of the fairing, under the internal bodywork, act on the adjuster ("1" left side / "2" right side). **TIGHTEN** (clockwise) to raise the beam **UNSCREW** it (anticlockwise) to lower the light beam.
- These two adjuster screws may be used to adjust the vertical alignment of the low beam headlight beam.

NOTE

CHECK THAT THE VERTICAL ALIGNMENT OF THE BEAM IS CORRECT.

(HIGH BEAM HEADLIGHT)

- Operating from underneath the headlamp unit, turn the adjuster screw (3). **TIGHTEN** (clockwise) to lower the light beam; **LOOSEN** (anticlockwise) to raise the beam.
- This adjuster screw may be used to adjust the vertical alignment of the high beam headlight beam.

NOTE

CHECK THAT THE VERTICAL ALIGNMENT OF THE BEAM IS CORRECT.

Rear optical unit

CAUTION

THE TAIL LIGHT ASSEMBLY MUST BE REMOVED, CHECKED AND, IF NECESSARY, REPLACED BY AN Authorised Aprilia Dealer.

Rear turn indicators

NOTE

FOR REMOVING, CHECKING AND REPLACING THE REAR INDICATORS, PLEASE SEE AN Authorised Aprilia Dealership

Number plate light

NOTE

TO HAVE THE LICENCE PLATE LIGHT REMOVED, CHECKED AND, IF NECESSARY, REPLACED, TAKE THE VEHICLE TO AN Official Aprilia Dealer

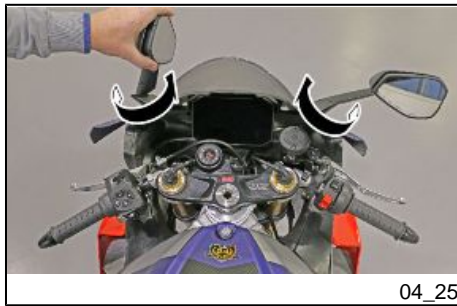

04_25

Rear-view mirrors (04_25, 04_26)

- The rear view mirrors may be folded inwards towards the rider.



04_26

- If necessary, adjust the position of the rear view mirrors as shown in the figure.

CAUTION

THE VEHICLE MAY NOT BE RIDDEN ON PUBLIC ROADS WITH THE REAR VIEW MIRRORS REMOVED.

CAUTION

THE REAR VIEW MIRRORS ARE FASTENER ELEMENTS OF THE TOP FAIRING. WHEN REMOVING THE REAR VIEW MIRRORS (PERMITTED FOR TRACK USE ONLY), THEY MUST BE REPLACED WITH SUITABLE SCREWS.

Front and rear disc brake (04_27, 04_28, 04_29)

CAUTION



CHECK BRAKE PADS FOR WEAR MAINLY BEFORE EACH RIDE.



04_27

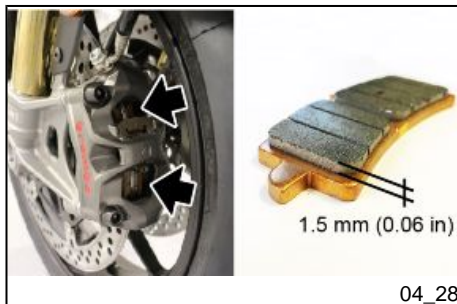

04_28

To perform a quick pad wear check:

- Rest the vehicle on its stand.
- Carry out a visual inspection of brake disc and pads as follows:
 - from the top rear side to check the front brake callipers (1);
 - from the bottom rear side to check the rear brake calliper (2).

CAUTION

EXCESSIVE WEAR OF THE FRICTION MATERIAL MAKES THE PAD METAL SUPPORT GET INTO CONTACT WITH THE DISC, WHICH RESULTS IN A METALLIC NOISE AND SPARKS IN THE CALLIPER; THEREFORE, BRAKING EFFICIENCY AND DISC SAFETY AND INTEGRITY ARE AT RISK.

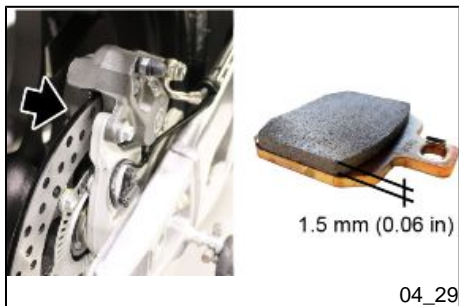

If the friction material thickness (even of one front (3) or rear (4) pad) is reduced to a value of about **1.5 mm (0.06 in)** (or even if one of the wear indicators is not very visible), contact an Authorised **Aprilia** Dealer to replace all the brake callipers.



USE ONLY ORIGINAL BRAKE PADS.

THE USE OF BRAKE PADS OTHER THAN ORIGINAL ONES CAN COMPROMISE PERFORMANCE AND/OR DAMAGE THE BRAKING SYSTEM.

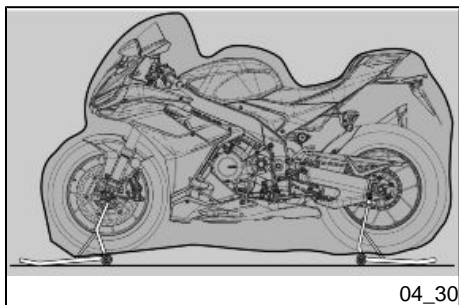

Periods of inactivity (04_30)

A number of precautionary measures must be taken to prevent the possible consequences of prolonged lack of usage of the vehicle. Besides, it is necessary to carry out general repairs and checks before garaging the motorcycle as one can forget to do so afterwards.

Proceed as follows:

- Remove the battery.
- Wash and dry the motorcycle.
- Polish the painted surfaces.
- Inflate the tyres.
- Set the vehicle in a room with no heating or humidity, with minimum temperature variations and not exposed to sun rays.
- Wrap and tie a plastic bag around the exhaust pipe opening to keep moisture out.

NOTE

USE A SUITABLE SUPPORT TO LIFT THE VEHICLE WITH BOTH TYRES OFF THE GROUND.

- Place the vehicle on the specific front stand (optional) and rear stand (optional).
- Cover the vehicle (do not use plastic or waterproof materials).

AFTER STORAGE

NOTE

REMOVE THE PLASTIC BAG FROM THE END OF THE SILENCER.

- Uncover and clean the vehicle.
- Check the battery for correct charge and install it.
- Refill the fuel tank.
- Carry out the pre-ride checks.

CAUTION



AS A TEST, RIDE THE MOTORCYCLE FOR A FEW KILOMETRES AT A MODERATE SPEED AND AWAY FROM TRAFFIC AREAS.

Cleaning the vehicle (04_31, 04_32, 04_33)

Clean the motorcycle frequently if exposed to adverse conditions, such as:

- Air pollution (cities and industrial areas).
- Salinity and humidity in the atmosphere (seashore areas, hot and wet weather).
- Special environmental/seasonal conditions (use of salt, anti-icing chemical products on the roads in winter).
- Always clean off any smog and pollution residue, tar stains, insects, bird droppings, etc. from the bodywork.

- Avoid parking the vehicle under trees. During some seasons, resins, fruits or leaves containing aggressive chemical substances that may damage the paintwork may fall from trees.
- Clean the dashboard with a soft, damp cloth.

CAUTION

BEFORE WASHING THE VEHICLE, COVER THE ENGINE AIR INTAKES AND THE EXHAUST PIPES.

CAUTION

AFTER CLEANING YOUR MOTORCYCLE, BRAKING EFFICIENCY MAY BE TEMPORARILY AFFECTED DUE TO THE PRESENCE OF WATER ON THE FRICTION SURFACES OF THE BRAKING CIRCUIT. ALLOW LONGER BRAKING DISTANCES TO PREVENT ACCIDENTS. BRAKE REPEATEDLY TO RESTORE NORMAL OPERATION. CARRY OUT THE PRE-RIDE CHECKS.

CAUTION**WARNING**

AFTER HEAVY RAIN, WASHING OR IN CASE OF RAPID TEMPERATURE CHANGES, THE LENSES OF THE FRONT LIGHT ASSEMBLY MAY BECOME FOGGY.

THIS STATE IS DUE TO THE TEMPERATURE DIFFERENCE BETWEEN THE OUTSIDE AND THE INSIDE AND DOES NOT INDICATE A FAULT OF THE FRONT LIGHT ASSEMBLY.

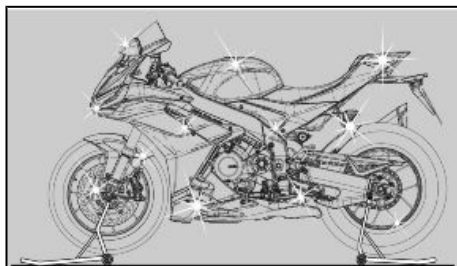

04_31

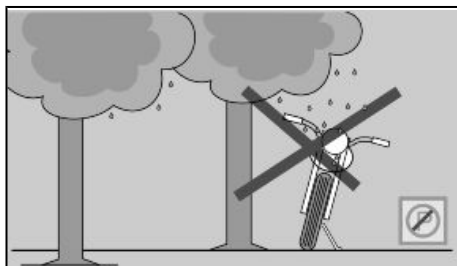

04_32

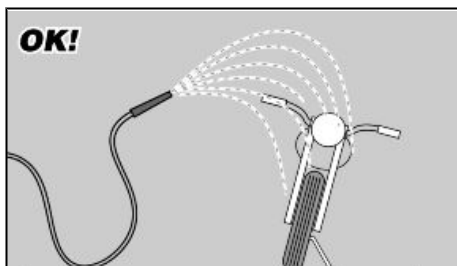

04_33

To remove dirt and mud accumulated on painted surfaces, wet the soiled areas thoroughly with a low-pressure water jet, then remove dirt and mud with a soft car body sponge soaked abundantly in a solution of car body shampoo in water (2 - 4% shampoo dissolved in water). Then rinse with plenty of water, and dry with a chamois leather. To clean the engine outer parts, use degreasing detergent, brushes and old cloths. Wash anodised or painted aluminium parts with neutral soap and water. Using aggressive detergents may damage the surface treatment of these components.



TO CLEAN THE LIGHT ASSEMBLIES, USE A SPONGE SOAKED IN WATER AND MILD DETERGENT, GENTLY RUBBING THE SURFACE AND RINSING FREQUENTLY WITH PLENTY OF WATER.

DO NOT CLEAN THE FRONT LIGHT ASSEMBLY WITH DETERGENTS CONTAINING TENSIOACTIVE AGENTS AND/OR ALCOHOL.

REMEMBER TO CLEAN THE VEHICLE CAREFULLY BEFORE APPLYING SILICON WAX POLISH. DO NOT POLISH MATT-PAINTED SURFACES WITH POLISHING PASTE. THE VEHICLE SHOULD NEVER BE WASHED IN DIRECT SUNLIGHT, ESPECIALLY DURING SUMMER, OR WITH THE BODYWORK STILL HOT AS THE CAR SHAMPOO CAN DAMAGE THE PAINTWORK IF IT DRIES BEFORE BEING RINSED OFF.

CAUTION

NEVER USE CLOTHS SOAKED IN PETROL, DIESEL OIL OR KEROSENE FOR CLEANING THE PAINTED OR PLASTIC SURFACES SO AS NOT TO DAMAGE THE LUSTRE FINISH OR ALTER THE MECHANICAL PROPERTIES.

CAUTION



DO NOT USE WATER (OR LIQUIDS) AT TEMPERATURES OVER 40°C (104°F) WHEN CLEANING THE VEHICLE PLASTIC PARTS. DO NOT AIM HIGH PRESSURE AIR/WATER JETS OR STEAM JETS DIRECTLY ON THESE COMPO-

NENTS. DO NOT USE ALCOHOL OR SOLVENTS TO CLEAN ANY RUBBER OR PLASTIC SADDLE COMPONENTS USE WATER AND MILD SOAP.

CAUTION

DO NOT USE SOLVENTS OR PETROL BY-PRODUCTS (ACETONE, TRICHLOROETHYLENE, TURPENTINE, PETROL, THINNERS) TO CLEAN THE SADDLE. USE INSTEAD DETERGENTS WITH SURFACE ACTIVE AGENTS NOT EXCEEDING 5% (NEUTRAL SOAP, DEGREASING DETERGENTS OR ALCOHOL).

DRY THE SADDLE WELL AFTER CLEANING.

CAUTION



DO NOT APPLY PROTECTIVE WAX ON THE SADDLE AS IT MAY BECOME SLIPPERY.

Lubricate the following components after washing the vehicle:

- drive chain;
- lever controls;
- pedal controls;
- clutch cable;
- ignition switch.

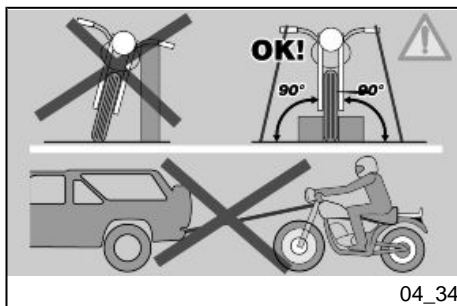

Transport (04_34)

NOTE



BEFORE TRANSPORTING THE VEHICLE, THE FUEL TANK MUST BE EMPTIED ADEQUATELY AND YOU MUST CHECK THAT IT IS COMPLETELY DRY.

DURING TRANSPORT, THE VEHICLE SHOULD BE UPRIGHT AND SECURELY ANCHORED AND SHOULD HAVE THE FIRST GEAR ENGAGED SO AS TO AVOID POSSIBLE FUEL, OIL OR COOLANT LEAKS.

IN CASE OF FAILURE, DO NOT TOW THE VEHICLE BUT CONTACT A ROAD ASSISTANCE SERVICE INSTEAD TO HAVE THE INFLAMMABLE FLUIDS DRAINED .

- Fold the rear view mirrors inwards to reduce the risk of damage.

Transmission chain



AN EXCESSIVELY LOOSE DRIVE CHAIN MAY DETACH FROM THE FRONT PINION OR SPROCKET, CAUSING AN ACCIDENT OR SIGNIFICANT DAMAGES TO PERSONS AND TO THE VEHICLE. CHECK REGULARLY THE CLEARANCE OF THE DRIVE CHAIN AND ADJUST THE CHAIN IF NECESSARY. TO CHANGE THE DRIVE CHAIN, CONTACT AN Authorised Aprilia Dealer, WHICH WILL BE PLEASED TO PROVIDE YOU WITH QUICK AND THOROUGH SERVICE.

CAUTION

INCORRECT MAINTENANCE MAY CAUSE EARLY WEAR OF THE DRIVE CHAIN AND/OR DAMAGE THE FRONT PINION AND/OR THE REAR SPROCKET. PERFORM DRIVE CHAIN MAINTENANCE OPERATIONS MORE FREQUENTLY IF YOU RIDE THE VEHICLE IN EXTREME CONDITIONS OR ON DUSTY AND/OR MUDDY ROADS.

CAUTION

DO NOT MODIFY THE FINAL DRIVE GEAR RATIO OR THE NUMBER OF LINKS IN THE CHAIN.

Characteristic**Final drive ratio**

16 / 41

Type

525

With sealed master link

Model

Regina 110 links

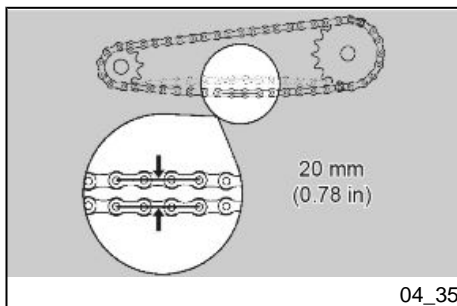

Chain backlash check (04_35)

To check the clearance:

- Shut off the engine.
- Rest the vehicle on its stand.
- Select neutral.
- Check that the vertical oscillation at a point between the pinion and the sprocket on the lower branch of the chain is about **20 mm (0.78 in)**.
- Move the vehicle forwards to check the vertical deflection of the chain in other positions; the chain deflection must be constant throughout the entire rotation of the wheel.

if the clearance is uniform, but greater or less than **20 mm (0.78 in)**, carry out the adjustment.

CAUTION

IF THE CLEARANCE IS GREATER IN SOME POSITIONS IT MEANS THAT SOME ELEMENTS OF THE CHAIN ARE CRUSHED OR HAVE SEIZED UP. IN THIS CASE THE CHAIN SHOULD BE REPLACED.

LUBRICATE THE CHAIN REGULARLY TO PREVENT THE RISK OF SEIZURE.

Chain backlash adjustment



ANY WORK ON THE DRIVE CHAIN MUST BE PERFORMED BY AN Authorised Aprilia Dealer.

Checking wear of chain, front and rear sprockets

Also check the following parts and check that the chain, the front sprocket and the rear sprocket do not have:

- damaged rollers.
- loosened pins.
- dry, corroded, crushed or seized links.
- excessive wear.
- Missing sealing rings.
- excessively worn or damaged front or rear sprocket teeth.

CAUTION

IF THE CHAIN ROLLERS ARE DAMAGED, THE PINS ARE LOOSE AND/OR THE SEAL RINGS ARE DAMAGED OR MISSING, THE ENTIRE CHAIN UNIT (PINION, SPROCKET AND CHAIN) NEEDS TO BE REPLACED.

CAUTION

LUBRICATE THE CHAIN AT FREQUENT INTERVALS, ESPECIALLY IF ANY DRY OR CORRODED PARTS ARE NOTED. CRUSHED OR SEIZED LINKS MUST BE LUBRICATED AND RESTORED TO PROPER WORKING ORDER. IF THIS IS NOT POSSIBLE, HAVE THE CHAIN REPLACED BY AN Authorised Aprilia Dealer.

Chain lubrication and cleaning

Do not wash the chain using water jets, vapour jets, high-pressure water jets or highly flammable solvents.

- Wash the chain with fuel oil or kerosene. Maintenance operations should be more frequent if there are signs of early rust.

Lubricate the chain whenever necessary.

- After washing and drying the chain, lubricate it with spray grease for sealed chains.



THE DRIVE CHAIN IS FITTED WITH RUBBER O-RINGS BETWEEN ITS SIDE PLATES IN ORDER TO RETAIN THE LUBRICATING GREASE. PROCEED WITH

THE UTMOST CAUTION WHEN ADJUSTING, LUBRICATING, WASHING OR REPLACING THE CHAIN.

COMMERCIALY AVAILABLE CHAIN LUBRICANTS MAY CONTAIN SUBSTANCES THAT DAMAGE THE RUBBER O-RINGS FITTED ON THE CHAIN.

DO NOT USE THE VEHICLE IMMEDIATELY AFTER LUBRICATING THE CHAIN SINCE THE LUBRICANT WOULD BE SPRAYED OUT AND CONTAMINATE THE SURROUNDING AREA.

RSV4 1100



Chap. 05 Technical data

DIMENSIONS AND MASS

Max. length	2,055 mm (80.90 in)
Max. width (at handlebar)	735 mm (28.94 in)
Max. height (to top fairing)	1165 mm (45.86 in)
Wheelbase	1,435 mm (56.50 in)
Kerb weight	202 kg (445.33 lb)
Weight fully loaded	277 kg (610.67 lb) (rider only)

ENGINE

Model	V4
Type	65° longitudinal V-4, 4-stroke, 4 valves per cylinder, double overhead camshafts.
Engine capacity	1099 cc (67.06 cu in)
Bore / stroke	81 mm / 53,32 mm (3.19 in / 2.09 in)
Compression ratio	13.6 +/- 0.5: 1
Idle engine speed	1500 +/- 100 rpm

Engine revs at maximum speed	13600 +/- 100 rpm
Clutch	Multi plate wet clutch with mechanical control lever on left side of the handlebar. Anti-juddering and slipper clutch systems
Starting	Electric
Timing system	Morse chain on intake camshaft, cam to cam gear, bucket tappets and valve clearance adjustments with calibrated pads
Lubrication system	Wet sump with oil radiator
Oil pump	Dual trochoidal pump (lubrication + cooling)
Oil filter	With external cartridge filter
Cooling	Liquid
Cooling system	3-way thermostatic valve, cooling radiator with electric fan and expansion tank
Coolant pump	Centrifugal bearingless aspirating pump with integrated ceramic gasket
Air filter	Polyester

CAPACITY

Fuel tank capacity (including reserve)	17.9 l (3.93 UK gal; 4.72 US gal)
Fuel tank reserve capacity	4 l (0.88 UK gal; 1.06 US gal)
Engine oil	oil and filter change 4.1 l (0.90 UK gal)
Coolant	2.7 l (0.59 UK gal)
Seats	2
Maximum weight limit	401 kg (884.05 lb) (rider + passenger + luggage)

DRIVE RATIOS

Primary drive ratio	44 / 73 (with gears)
Drive ratio, 1st gear	15 / 39 (secondary)
Drive ratio, 2nd gear	16 / 33 (secondary)
Drive ratio, 3rd gear	20 / 34 (secondary)
Drive ratio, 4th gear	21 / 31 (secondary)
Drive ratio, 5th gear	26 / 34 (secondary)
Drive ratio, 6th gear	27 / 33 (secondary)

Final drive ratio	16 / 41
-------------------	---------

DRIVE CHAIN

Type	525 With sealed master link
Model	Regina 110 links

ELECTRONIC CONTROL SYSTEMS

a-PRC system	(Aprilia Performance Ride Control) which includes: ALC (controlled launch), AEM (engine map management system), AEB (engine brake map management system), ASC (suspension electronic control) (if available), ABS (anti-lock braking system), ATC (traction control), AWC (wheelie control), AQS (Assisted upshift and downshift without using the clutch), PIT (pit lane speed control).
--------------	--

POWER SUPPLY

Fuel	Unleaded gasoline E10 (95 R.O.N.)
------	-----------------------------------

FUEL SUPPLY SYSTEM

Throttle body diameter	48 mm (1.89 in)
Type	Electronic injection with 2 injectors per cylinder, 4 motorised throttle bodies (Ride by wire) with fixed height air intakes differentiated per main bearing (front/rear). 2 dynamic air intakes. Selectable multimap.

FRAME

Type	Adjustable aluminium, dual beam chassis with pressed and cast sheet elements.
Steering rake angle	26.5° (measurements with reference to bare chassis)

SUSPENSIONS

Front fork - RSV4 1100 Factory (Ohlins - ASC)	With upside-down stanchions, electronic adjustment and hydraulic operation, 1.69 in (43 mm) diam. stanchions with Tin surface coating and NIX cartridge
Front fork - RSV4 1100 (Sachs - NO ASC)	With upside down stanchions, adjustable hydraulic damping, stanchions diam 43 mm (1.69 in).
Front stroke (Ohlins - ASC)	125 mm (4.92 in)
Front stroke (Sachs - NO ASC)	127 mm (4.99 in)
Rear shock absorber - RSV4 1100 Factory (Ohlins - ASC)	With progressive linkage with APS system. Shock absorber with piggy-back that can be electronically adjusted for hydraulic brake compression and extension and mechanically adjusted for spring pre-loading.
Rear shock absorber - RSV4 1100 (Sachs - NO ASC)	With progressive linkage with APS system. Shock absorber with piggy-back that can be adjusted for spring pre-loading, wheelbase length and hydraulic brake compression and extension .
Rear stroke	62 mm (2.44 in)
Steering damper - RSV4 1100 Factory (Ohlins - ASC)	With electronically adjustable hydraulic brake

Steering damper - RSV4 1100
(Sachs - NO ASC)

With adjustable hydraulic brake

BRAKES

Front	Dual 330 mm (12.99 inches) diam. floating disc, forged radial-mounted single block callipers and four pistons 34 mm diam. (1.33 inches) and 2 pads - radial pump and brake pipe in metal braid.
-------	---

Rear	disc brake -220 mm diam. (8.66 inches), 2-piston callipers - 32 mm diam. (1.25 inches) - pump with built-in tank and metal braid pipe.
------	--

WHEELS

Front wheel	3.50 x 17"
-------------	------------

Rear wheel	6.00 x 17"
------------	------------

TYRES

Front tire	120/70 ZR17 (58W)
------------	-------------------

Inflation pressure	1 passenger: 2.3 bar (230 KPa) (33.36 PSI) 2 passengers: 2.5 bar (250 KPa) (36.26 PSI)
Rear tire	190/50 ZR17 (73W) 190/55 ZR17 (75W) 200/55 ZR17 (78W) (*) (*) For these specifications use only Pirelli Diablo Supercorsa SP tyres.
Inflation pressure	1 passenger: 2.5 bar (250 KPa) (36.26 PSI) 2 passengers: 2.8 bar (280 KPa) (40.61 PSI)

ELECTRICAL SYSTEM

Spark plugs	NGK IR MR9DI-7
Electrode gap	0.6 - 0.7 mm (0.023 - 0.027 in)
Battery	BS BATTERY BSLi-04 LITHIUM, 12V 48Wh 280A Alternative solution: YUASA YTZ10S, 12V 8.6 Ah

Coils	Stick coil
Recharging system	Flywheel with rare earth magnets
Alternator	360 W
Main fuse	30A
Secondary fuses	5A (4) - 7.5 A (3) - 15 A - 20 A
ABS fuses	10 A - 25 A
ASC fuse (if supplied)	7.5 A

FUNCTIONS: HEADLAMP/TAIL LIGHT/LICENCE PLATE LIGHT

High beam/low beam light	LED - 18W / 27W
Front DRL	LED - 2W / 10W
Turn indicators	LED - 2.7W
Rear running light / brake light	LED - 0.5W / 2.3W
Licence plate light	LED - 0.67W

INDICATOR LAMPS

MI	LED
----	-----

High beam light	LED
Cruise control	LED
ABS	LED
Turn indicators	LED
a-PRC	LED
DRL	LED
Fuel reserve	LED
Immobilizer	LED
Neutral	LED

RSV4 1100



Chap. 06 Programmed maintenance



06_01

Scheduled maintenance table (06_01, 06_02)

Adequate maintenance is fundamental to ensure long-lasting, optimum operation and performance of your vehicle.

For this reason a series of checks and maintenance services has been prepared, available for purchase separately, listed together in the chart on the following page. It is a good idea to report small performance anomalies right away to an **Authorised Service Centre**, without waiting for the next scheduled service, so they can be repaired immediately.

It is necessary to have your vehicle serviced to the prescribed intervals of time, even if you have not reached the predicted mileage. Services must be performed punctually at the correct intervals to maintain the validity of the warranty. For any additional information concerning Warranty procedures and 'Scheduled Maintenance', please consult the 'Warranty Conditions'.

NOTE

HALVE THE SERVICE INTERVALS INDICATED IF THE VEHICLE IS USED IN PARTICULARLY RAINY OR DUSTY CONDITIONS, ON POOR ROADS OR FOR HIGH PERFORMANCE RIDING.

I: CHECK AND CLEAN, ADJUST, LUBRICATE OR REPLACE, IF NECESSARY

C: CLEAN, R: REPLACE, A: ADJUST, L: LUBRICATE

- (1) Check at each engine start.
- (2) Check and clean and adjust or replace, if necessary, before every journey.
- (3) Check and clean, adjust or replace if necessary every 1,000 km (621.37 mi).
- (4) Replace every 4 years.
- (5) Every 5,000 Km (3,106.86 mi) if the vehicle is used for racing.
- (6) Every 10,000 Km (6,213.71 mi) if the vehicle is used for racing.

(7) Your RSV4 is equipped with a sophisticated system, based on exchangeable conical bushes that allow the modification of the steering angle for track use. In case of prolonged road use in conditions with uneven ground (e.g. use on pave, holes, speed bumps) can bring small adjustments that, in extreme cases, can cause a slight clearance to the handlebar. Therefore it is recommended to perform the check and adjustment operations at an Authorised Aprilia-Piaggio Workshop every 5,000 km (3,106.86 mi).

(8) Replace at whichever of the following occurs first: 40,000 km (24,854.85 mi) or 4 years.

SCHEDULED MAINTENANCE TABLE

Km x 1,000 (mi x 1,000)	1 (0.6)	10 (6.2)	20 (12.4)	30 (18.6)	40 (24.9)	EVERY 12 MONTHS	EVERY 24 MONTHS
Rear shock absorber (bearings - linkage systems) (5)			I		I	I	I
Motorcycle set up (5)	I	I	I	I	I		
Spark plug			R		R		
Drive chain (3)	I - L	I - L	I - L	I - L	I - L	I	I
Clutch cable	L	L	L	L	L	L	L
Exhaust valve control cables (5)	A	A	A	A	A	A	A
Crown wheel - sprocket (5)		I	I	I	I		
Steering bearings and steering play (7)	I	I	I	I	I	I	I
Wheel bearings - Wheels (5)	I	I	I	I	I	I	I
Diagnosis by tool	I	I	I	I	I	I	I
Brake discs (5) - Pads wear (2)	I	I	I	I	I	I	I
Air filter (5)		I	R	I	R		

Km x 1,000 (mi x 1,000)	1 (0.6)	10 (6.2)	20 (12.4)	30 (18.6)	40 (24.9)	EVERY 12 MONTHS	EVERY 24 MONTHS
Engine oil filter (5)	R	R	R	R	R	R	R
Raked			I		I	I	I
General vehicle operation (5)	I	I	I	I	I	I	I
Valve clearance (6)			A		A		
Cooling system (5)		I	I	I	I		
Brake systems (5)	I	I	I	I	I	I	I
Light circuit	I	I	I	I	I	I	I
Safety switches (stand, stop, clutch, extra negative stroke, gas control)	I	I	I	I	I	I	I
Brake Fluid	I	I	I	I	I	I	R
Coolant	I	I	I	I	I	I	R
Fork oil (6) (8)					R		
Engine oil (5)	R	R	R	R	R	R	R
Headlight aiming		I	I	I	I		
Fork oil seals (5)		I		I			
Tyres - pressure / wear (2)	I	I	I	I	I	I	I
Nut/bolt tightness (5)	I	I	I	I	I		
Flexible coupling pin nuts tightening	I						
Clutch cover, flywheel and sump screw tightness	I	I	I	I	I		
Fault indicator light on instrument cluster (1)							
Fuel lines (4)		I	I	I	I	I	I

Km x 1,000 (mi x 1,000)	1 (0.6)	10 (6.2)	20 (12.4)	30 (18.6)	40 (24.9)	EVERY 12 MONTHS	EVERY 24 MONTHS
Clutch wear (6)							

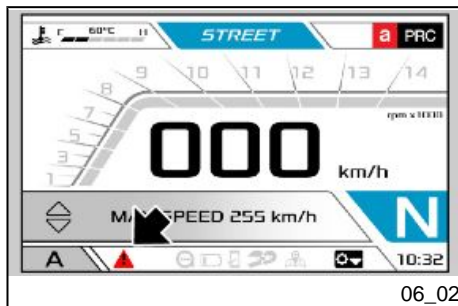

The scheduled maintenance table refers to road use. In case of using the new RSV4 on a competitive level, as for sport events and use on the track, in order to correctly monitor the effective degree of technological stress of the mechanical components, an electric device intervenes that registers the engine performance and allows to plan eventual maintenance.

Therefore, when the general warning light (see figure) steadily lights up for 2 seconds, each 120 seconds, it is necessary to contact an Authorised Service Centre to plan the specific maintenance intervention, which is recommended by the manufacturer.

Recommended products (06_03)

Piaggio Group recommends the use of products from its Castrol official partner for the scheduled maintenance of its vehicles.

Only use lubricants and fluids which meet or exceed the performance characteristics specified. This also applies when topping up only.



TABLE OF RECOMMENDED PRODUCTS

Product	Description	Specifications
Engine oil 10W -50	Synthetic-based lubricant for high performance four-stroke engines.	SAE 10W 50; API SL; JASO MA2
Lithium-based grease	Lithium-calcium soap based grease	colour - black, contains EP (Extreme Pressure) additives, excellent water-repellent properties
Anti-freeze liquid, ready to use, colour red	Ethylene glycol antifreeze liquid with organic inhibition additives. Red, ready to use.	ASTM D 3306 - ASTM D 4656 - ASTM D 4985 - CUNA NC 956-16
DOT 4 brake fluid	Synthetic brake fluid.	SAE J 1703; FMVSS 116; ISO 4925; CUNA NC 956 DOT4
ÖHLINS 5W	Öhlins fork oil.	SAE 5W
Hydraulic fluid HVI 32	Fork oil	Application - Sachs; ISO-L-HV

TABLE OF CONTENTS

A

a-PRC setting buttons: 79
Advanced functions: 55
Air filter: 160
Alarms: 32

B

Battery: 14, 165–168
Brake: 14, 162, 181
Brake fluid: 14

C

Chain: 187, 189, 190
Clutch: 135
Clutch lever: 135
coolant: 13, 162
Coolant: 13, 162

D

Disc brake: 181

Display: 25

E

Engine oil: 13, 156–158
Engine stop: 84

F

Fork: 127, 130
Fuel: 12
Fuses: 171

G

Gearbox oil: 13

H

Headlight: 177
Horn: 80

I

Identification: 113
Immobilizer: 109
Instrument panel: 23

M

Maintenance: 155, 205, 206
Maintenance Table: 206
Mirrors: 180

O

Oil filter: 158

R

rear-view mirrors: 180
Recommended products:
209

S

Saddle: 110
Scheduled maintenance:
206
Shock absorber: 133
Shock absorbers: 121, 125
Spark plug: 160
Stand: 15, 147
Start-up: 84
Stop switch: 84

T

Technical data: 193
Transmission: 187
Turn indicators: 179
Tyres: 158

U

Use: 115, 167



THE VALUE OF SERVICE

Due to continuous updates and technical training programmes specific to Aprilia products, only **Aprilia** Official Network mechanics know this vehicle fully and have the specific tools necessary to carry out maintenance and repair operations correctly.

The reliability of the vehicle also depends on its mechanical conditions. Checking the vehicle before riding it, performing maintenance correctly and using only **original Aprilia spare parts** are essential factors for the reliability of your vehicle!

For information on the nearest **Official Dealer and/or Service Centre** consult our website:

www.aprilia.com

Only by requesting original Aprilia spare parts can you be of purchasing products that were developed and tested during the design and development of the vehicle itself. All Aprilia original spare parts undergo quality control procedures to guarantee reliability and durability.

The descriptions and images in this publication are given for illustrative purposes only.

While the basic features as described and illustrated in this manual remain unchanged, Piaggio & C. S.p.A. reserves the right, at any time and without being required to update this publication beforehand, to make any changes to components, parts or accessory supplies which it deems necessary to improve the product, or which are required for manufacturing or commercial reasons.

Not all versions/models shown in this publication are available in all countries. The availability of individual versions/models should be confirmed with the official Aprilia sales network.

The Aprilia trademark is the property of Piaggio & C. S.p.A.

© Copyright 2021 - Piaggio & C. S.p.A. All rights reserved. Reproduction of this publication in whole or in part is prohibited.

Piaggio & C. S.p.A. Viale Rinaldo Piaggio, 25 - 56025 PONTEDERA (PI), Italy

www.piaggio.com