

## **APRILIA WOULD LIKE TO THANK YOU**

for having chosen one of its products. We have compiled this booklet to provide a comprehensive overview of your vehicle's quality features. Please read it carefully before riding the vehicle for the first time. It contains information, tips and precautions for using your vehicle. It also describes features, details and devices to assure you that you have made the right choice. We believe that if you follow our suggestions, you will soon find yourself in harmony with your new vehicle, and ride it fully satisfied for a long time. This booklet forms an integral part of the vehicle; should the vehicle be sold, it must be transferred to the new owner.

# **SHIVER 900**



The instructions given in this manual are intended to provide a clear, simple guide to using your vehicle; it also describes routine maintenance procedures and regular checks that should be carried out on the vehicle at an **Aprilia Dealer or Authorised Workshop**. The booklet also contains instructions for simple repairs. Any operations not specifically described in this booklet require the use of special tools and/or particular technical knowledge: for these operations, please take your vehicle to an **Aprilia Dealer or Authorised Workshop**.



### **Personal safety**

Failure to completely observe these instructions will result in serious risk of personal injury.



### **Safeguarding the environment**

Sections marked with this symbol indicate the correct use of the vehicle to prevent damaging the environment.



### **Vehicle intactness**

The incomplete or non-observance of these regulations leads to the risk of serious damage to the vehicle and sometimes even the invalidity of the guarantee

*The symbols illustrated above are very important. They are used to highlight parts of the booklet that should be read with particular care. The different symbols are used to make each topic in the manual simple and quick to locate. Before starting the engine, read this booklet carefully, particularly the "SAFE RIDING" section. Your safety as well as other's does not only depend on the quickness of your reflexes and agility, but also on how well you know your vehicle, the state of maintenance of the vehicle itself and your knowledge of the rules for SAFE RIDING. For your safety, get to know your vehicle well so as to safely ride and master it given any riding condition. **IMPORTANT** This booklet is an integral part of the vehicle, and must be handed over to the new owner in the event of sale.*



# INDEX

<b>GENERAL RULES</b> .....	7	Immobilizer system operation.....	76
Foreword.....	8	Opening the saddle.....	77
Motorcycle care.....	8	Glove.....	78
Carbon monoxide.....	11	USB Port.....	78
Fuel.....	12	Identification.....	79
Hot components.....	12	<b>USE</b> .....	81
Coolant.....	13	Checks.....	82
Used engine oil and gearbox oil.....	13	Refuelling.....	85
Brake and clutch fluid.....	14	Rear shock absorbers adjustment.....	86
Battery hydrogen gas and electrolyte.....	14	Rear shock absorbers setting.....	88
Stand.....	15	Front fork adjustment.....	89
Reporting of defects that affect safety.....	15	Front fork setting.....	90
<b>VEHICLE</b> .....	17	Justering af greb til forbremse.....	91
Arrangement of the main components.....	19	Rear brake pedal adjustment.....	92
Dashboard.....	21	Clutch lever adjustment.....	92
Digital instrument panel.....	22	Running in.....	92
Light unit.....	23	Starting up the engine.....	93
Digital lcd display.....	23	Moving off / riding.....	96
Alarms.....	28	Stopping the engine.....	101
Mapping selection.....	31	Parking.....	101
Control buttons.....	33	Catalytic silencer.....	102
Advanced functions.....	34	Stand.....	103
Ignition switch.....	62	Suggestion to prevent theft.....	104
Locking the steering wheel.....	63	Safe driving.....	105
Horn button.....	64	Basic safety rules.....	106
Switch direction indicators.....	64	<b>MAINTENANCE</b> .....	111
High/low beam selector.....	65	Foreword.....	112
Passing button.....	66	Engine oil level check.....	112
Start-up button.....	66	Engine oil top-up.....	113
Engine stop switch.....	67	Engine oil change.....	113
Selector MODE.....	67	Engine oil filter replacement.....	114
System ABS.....	67	Tyres.....	114
System ATC (Aprilia Traction Control).....	71	Spark plug dismantlement.....	115

Removing the air filter.....	116
Cooling fluid level.....	116
Coolant check.....	117
Coolant top-up.....	117
Checking the brake oil level.....	118
Braking system fluid top up.....	118
Checking clutch fluid.....	119
Topping up clutch fluid.....	119
Battery removal.....	119
Checking the electrolyte level.....	120
Charging the battery.....	120
Long periods of inactivity.....	121
Fuses.....	122
Lamps.....	126
Headlight adjustment.....	127
Front direction indicators.....	128
Rear optical unit.....	129
Rear turn indicators.....	129
Number plate light.....	130
Rear-view mirrors.....	130
Front and rear disc brake.....	132
Periods of inactivity.....	133
Cleaning the vehicle.....	134
Transport.....	137
Transmission chain.....	138
Chain backlash check.....	139
Chain backlash adjustment.....	140
Checking wear of chain, front and rear sprockets.....	140
Chain lubrication and cleaning.....	141
<b>TECHNICAL DATA.....</b>	<b>143</b>
Data.....	150
<b>PROGRAMMED MAINTENANCE.....</b>	<b>153</b>
Scheduled maintenance table.....	154
Recommended products.....	156

# SHIVER 900



## Chap. 01 General rules

## Foreword

### NOTE

**CARRY OUT MAINTENANCE OPERATIONS AT HALF THE INTERVALS SPECIFIED IF THE VEHICLE IS USED IN PARTICULAR RAINY OR DUSTY CONDITIONS, OFF ROAD OR FOR TRACK USE.**

## Motorcycle care

Aprilia recommends using quality products for cleaning the vehicle. The use of unsuitable products can damage vehicle components. For cleaning do not use solvents such as "nitro thinner", "cold cleaning agents", fuels or the like, or cleaning products that contain alcohol.

### WASHING THE MOTORCYCLE

Aprilia recommends softening with plenty water and then carefully removing insects and stubborn stains before washing the vehicle.

To prevent stains, do not wash the motorcycle immediately after exposure to sunlight, and do not wash it in the sun.

If the vehicle is used during the winter months, be sure to frequently wash the motorcycle. To remove anti-icing salt sprayed on roads in the winter, wash the motorcycle with cold water immediately after use.

### CAUTION

**AFTER CLEANING YOUR MOTORCYCLE, THE EFFICIENCY OF THE BRAKING SYSTEM MAY BE TEMPORARILY AFFECTED DUE TO THE PRESENCE OF WATER ON THE FRICTION SURFACES. CONSIDER AN INCREASE IN BRAKING SPACE, OPERATE THE BRAKES REPEATEDLY TO RESTORE NORMAL CONDITIONS. CARRY OUT THE PRE-RIDE CHECKS BEFORE USE.**





**USE OF HOT WATER INTENSIFIES THE EFFECT OF THE SALT. USE ONLY PLENTY OF COLD WATER TO WASH AND REMOVE ANTI-ICING SALT**



**USE OF HIGH PRESSURE WASHING SYSTEMS (OR STEAM CLEANERS) CAN DAMAGE THE SEALS, OIL SEALS, BRAKING SYSTEM, ELECTRICAL SYSTEM AND THE SADDLE. DO NOT USE STEAM OR HIGH PRESSURE CLEANING SYSTEMS. DO NOT USE STEAM OR HIGH PRESSURE CLEANING SYSTEMS.**

## **CLEANING OF SENSITIVE PARTS**

### **BODYWORK**

To keep the motorcycle bright, wash it regularly, especially if used in areas with high levels of pollution or mud. Stubborn stains of tree resin, petrol, oil, brake liquid or bird droppings should be removed immediately, otherwise the stains risk becoming permanent.

After washing it is easy to identify marks and residual stains, remove them from the body using a soft cloth and brand-name, non-abrasive polish, and protect with a protective wax for cars. Periodic care, a thorough cleaning and regular protective wax for the bodywork preserves the aesthetic quality of the motorcycle over the long term.

### **PLASTIC COMPONENTS**



**IF THE PLASTIC COMPONENTS ARE CLEANED USING AGGRESSIVE AGENTS, THE SURFACE MAY BE DAMAGED. DO NOT USE CLEANING PRODUCTS CONTAINING ALCOHOL, SOLVENTS OR THAT ARE ABRASIVE FOR THE CLEANING**

**OF PLASTIC PARTS. ROTARY BRUSHES OR SPONGES WITH HARD SURFACES CAN MAKE SCRATCHES**

#### **CHROME PARTS AND POLISHED METAL**



**TREAT THE PARTS MADE OF CHROME, ALUMINIUM OR POLISHED STEEL IN A SPECIAL MANNER. WASH THEM WITH PLENTY OF WATER AND CAR SHAMPOO, POLISH AND REGULARLY BRIGHTEN THEM WITH POLISH PASTE, PROTECT THEM WITH WAXES OR SUITABLE ACID-FREE PRODUCTS (E.G. VASELINE)**

#### **RADIATOR**



**IF THE VEHICLE IS USED IN WINTER ON ROADS TREATED WITH SALT, WASH THE RADIATOR FREQUENTLY TO PREVENT COSMETIC DAMAGE TO THE FINISH AND THE RISK OF ENGINE OVERHEATING. WASH WITH PLENTY OF WATER. WASH WITH A LOW PRESSURE JET OF WATER, USING A GARDEN HOSE FOR EXAMPLE.**

#### **RUBBER PARTS**

Clean the rubber parts using water and mild shampoo (brand-name, suitable for car bodies)



**THE USE OF SILICONE SPRAY TO CLEAN THE RUBBER SEALS MAY CAUSE DAMAGE. DO NOT USE OTHER PRODUCTS CONTAINING SILICON FOR CLEANING THE MOTORCYCLE**

### **Carbon monoxide**

If you need to keep the engine running while working on the vehicle, please ensure that you do so in an open or very well ventilated area. Never run the engine in an enclosed area. If you do work in an enclosed area, make sure to use a fume extraction system.

#### **CAUTION**



**EXHAUST EMISSIONS CONTAIN CARBON MONOXIDE, A POISONOUS GAS WHICH CAN CAUSE LOSS OF CONSCIOUSNESS AND EVEN DEATH.**

#### **CAUTION**



**CARBON MONOXIDE IS ODOURLESS AND COLOURLESS, THEREFORE IT CANNOT BE DETECTED BY SMELL, SIGHT OR OTHER SENSES. DO NOT BREATHE IN EXHAUST FUMES UNDER ANY CIRCUMSTANCES.**

## Fuel

### CAUTION



**FUEL USED TO DRIVE EXPLOSION ENGINES IS HIGHLY INFLAMMABLE AND CAN BECOME EXPLOSIVE UNDER SPECIFIC CONDITIONS. IT IS THEREFORE RECOMMENDED TO CARRY OUT REFUELLING AND MAINTENANCE PROCEDURES IN A VENTILATED AREA WITH THE ENGINE SWITCHED OFF. DO NOT SMOKE DURING REFUELLING OR NEAR FUEL VAPOUR. AVOID ANY CONTACT WITH NAKED FLAME, SPARKS OR OTHER HEAT SOURCES WHICH MAY CAUSE IGNITION OR EXPLOSION.**

**DO NOT ALLOW FUEL TO DISPERSE INTO THE ENVIRONMENT.**

**KEEP OUT OF THE REACH OF CHILDREN.**



**IF THE VEHICLE FALLS OR IS ON A STEEP INCLINE FUEL CAN LEAK.**

## Hot components

The engine and the exhaust system components get very hot and remain in this condition for a certain time interval after the engine has been switched off. Before handling these components, make sure that you are wearing insulating gloves or wait until the engine and the exhaust system have cooled down.

## Coolant

Coolant contains ethylene glycol, which may be flammable in certain conditions. Ethylene glycol burns with an invisible flame which may still cause burns.

### CAUTION



**TAKE PARTICULAR CARE NOT TO SPILL COOLANT ONTO HOT PARTS OR THE ENGINE AND EXHAUST SYSTEM; THE FLUID MAY CATCH FIRE AND BURN WITH INVISIBLE FLAMES. WHEN CARRYING OUT MAINTENANCE OPERATIONS, IT IS ADVISABLE TO WEAR LATEX GLOVES. WHILE POISONOUS, COOLANT HAS A SWEET TASTE WHICH MAKES IT EXTREMELY APPEALING TO ANIMALS. NEVER LEAVE COOLANT IN OPEN CONTAINERS WHERE IT MAY BE REACHED AND DRUNK BY AN ANIMAL.**

**KEEP OUT OF THE REACH OF CHILDREN.**

**NEVER REMOVE THE RADIATOR CAP WHILE THE ENGINE IS STILL HOT. COOLANT IS UNDER PRESSURE AND MAY CAUSE BURNS.**

## Used engine oil and gearbox oil

### CAUTION



**WHEN CARRYING OUT MAINTENANCE OPERATIONS, IT IS ADVISABLE TO WEAR PROTECTIVE IMPERMEABLE GLOVES.**

**THE ENGINE OR GEARBOX OIL MAY CAUSE SERIOUS INJURIES TO THE SKIN IF HANDLED FOR PROLONGED PERIODS OF TIME AND ON A REGULAR BASIS.**

**WASH YOUR HANDS CAREFULLY AFTER HANDLING OIL.**

**HAND THE OIL OVER TO OR HAVE IT COLLECTED BY THE NEAREST USED OIL RECYCLING COMPANY OR THE SUPPLIER.**

**DO NOT DISPOSE OF OIL IN THE ENVIRONMENT**

**KEEP OUT OF THE REACH OF CHILDREN.**

### **Brake and clutch fluid**



**BRAKE FLUID MAY BE HARMFUL TO PAINTWORK, PLASTIC AND RUBBER. WHEN SERVICING THE BRAKING SYSTEM PROTECT THESE COMPONENTS WITH A CLEAN CLOTH. ALWAYS WEAR PROTECTIVE GOGGLES WHEN SERVICING THESE SYSTEMS. BRAKE FLUID IS EXTREMELY HARMFUL TO THE EYES. IN THE EVENT OF ACCIDENTAL CONTACT WITH THE EYES, RINSE THE EYES IMMEDIATELY WITH PLENTY OF COOL, CLEAN WATER AND SEEK IMMEDIATE MEDICAL ATTENTION.**

**KEEP OUT OF THE REACH OF CHILDREN.**

### **Battery hydrogen gas and electrolyte**

**CAUTION**



**THE BATTERY ELECTROLYTE IS TOXIC, CORROSIVE AND AS IT CONTAINS SULPHURIC ACID, IT CAN CAUSE BURNS WHEN IN CONTACT WITH THE SKIN. WHEN HANDLING BATTERY ELECTROLYTE, WEAR TIGHT-FITTING GLOVES AND PROTECTIVE APPAREL. IN THE EVENT OF SKIN CONTACT WITH THE ELECTROLYTIC FLUID, RINSE WELL WITH PLENTY OF CLEAN WATER. IT IS PARTICULARLY IMPORTANT TO PROTECT YOUR EYES BECAUSE EVEN TINY**

AMOUNTS OF BATTERY ACID MAY CAUSE BLINDNESS. IF THE FLUID GETS IN CONTACT WITH YOUR EYES, WASH WITH ABUNDANT WATER FOR FIFTEEN MINUTES AND CONSULT AN EYE SPECIALIST IMMEDIATELY. THE BATTERY RELEASES EXPLOSIVE GASES; KEEP IT AWAY FROM FLAMES, SPARKS, CIGARETTES OR ANY OTHER HEAT SOURCES. ENSURE ADEQUATE VENTILATION WHEN SERVICING OR RECHARGING THE BATTERY.

KEEP OUT OF THE REACH OF CHILDREN.

BATTERY LIQUID IS CORROSIVE. DO NOT POUR OR SPILL ON PLASTIC COMPONENTS IN PARTICULAR. ENSURE THAT THE ELECTROLYTIC ACID IS COMPATIBLE WITH THE BATTERY BEING ACTIVATED.

## Stand



BEFORE SETTING OFF, MAKE SURE THE STAND HAS BEEN COMPLETELY RETRACTED TO ITS POSITION.

DO NOT REST THE RIDER OR PASSENGER WEIGHT ON THE SIDE STAND.

## Reporting of defects that affect safety

Unless otherwise specified in this Use and Maintenance Manual, do not remove any mechanical or electrical component.

### CAUTION

SOME OF THE CONNECTORS ON THE VEHICLE MAY BE ACCIDENTALLY SWAPPED, AND MAY COMPROMISE NORMAL VEHICLE OPERATION AND/OR

**CAUSE IRREPARABLE DAMAGE TO PARTS OF THE VEHICLE IF INCORRECTLY INSTALLED.**



# SHIVER 900



**Chap. 02**  
**Vehicle**

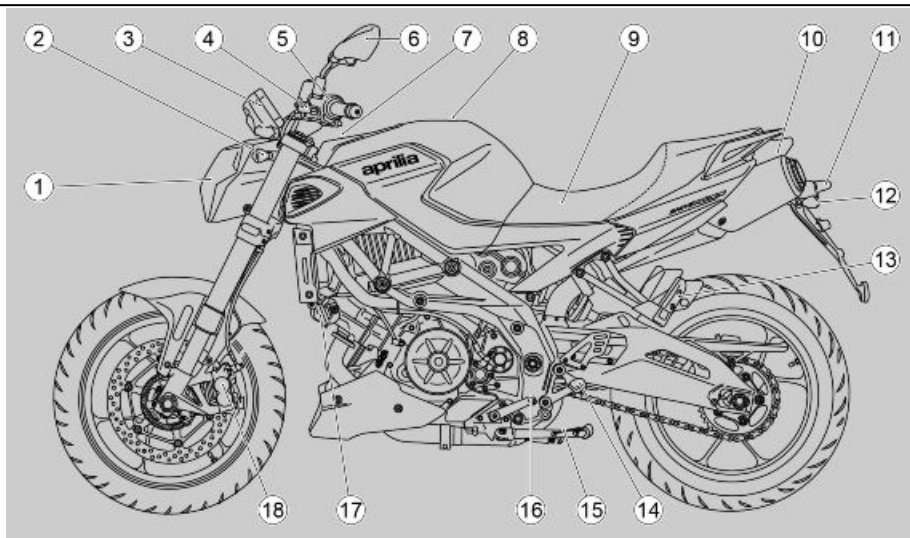

02\_01

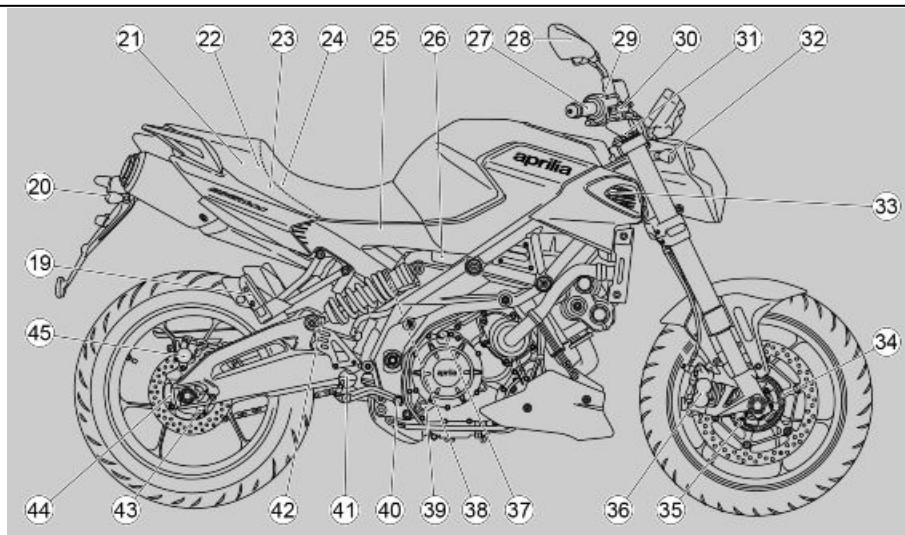

02\_02

### Arrangement of the main components (02\_02)

#### Key:

1. Headlamp
2. Front left turn indicator
3. Dashboard
4. Clutch lever
5. Left light switch
6. Left rear-view mirror
7. Ignition switch
8. Fuel tank cap
9. Passenger/rider saddle
10. Taillight
11. Licence plate light

12. Rear left turn indicator
13. Passenger left footrest (snap on, closed/open)
14. Rider left footrest
15. Side stand
16. Gear shift lever
17. Horn
18. Front left brake calliper
19. Passenger right footrest (snap on, closed/open)
20. Rear right turn indicator
21. Main fuses
22. Secondary fuse box
23. Connector for AMP control unit pre-installation
24. ABS fuse
25. Battery
26. Rear brake oil tank
27. Ride by Wire throttle handle
28. Right rear-view mirror
29. Right light switch
30. Front brake lever
31. Front fork adjusters
32. Front right turn indicator
33. Coolant expansion tank
34. Front tone wheel
35. Front ABS sensor
36. Front right brake calliper
37. Engine oil load cap
38. Nut for adjusting shock absorber spring preload
39. Engine oil level inspection port
40. Rear brake lever
41. Rider right footrest
42. Screw adjusting rear shock absorber extension
43. Rear ABS sensor
44. Rear tone wheel
45. Rear brake calliper

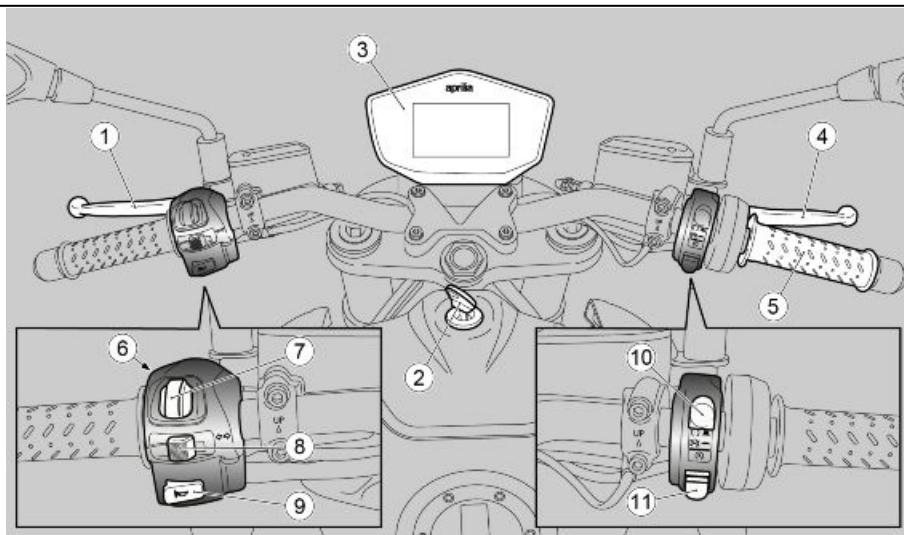

02\_03

## Dashboard (02\_03)

### Key

1. Clutch control lever
2. Ignition switch /steering lock
3. Dashboard panel
4. Front brake lever
5. Throttle grip
6. High beam flashing switch
7. MODE selector switch
8. Turn indicator control
9. Horn button
10. Engine stop button
11. Engine stop button

## 11. Starter button / mapping selection

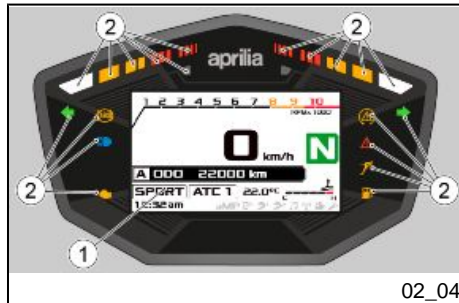

02\_04

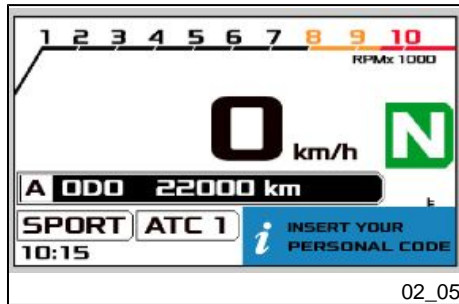

02\_05

**Digital instrument panel (02\_04, 02\_05)****Key:**

1. Multifunctional digital display box
2. Indicator lights.

The dashboard has an immobilizer system which prevents start-up in case the system does not identify a key which has been stored before.

The vehicle is supplied with two keys already programmed. The dashboard accepts a maximum of four keys at the same time: contact an Authorised **Aprilia** Dealer to enable these keys or to disable a key that has been lost. Upon vehicle delivery, for approximately ten seconds after turning the key to ON position, the instrument panel memorizes the entered five-digit personal code.

To enter the personal code, refer to chapter "Advanced functions"

On the value located to the right of the display, a variable value from 0 to 9 is shown by using the MODE selector. Confirm the selection by pressing on the central part of the MODE selector until all five digits are entered. Once confirmed, the display shows the code in a fixed manner, this is so the user can check the code that has been entered. To remove the screen showing the code that has been entered, carry out a KEY OFF- KEY ON cycle. In the future you can always change the last code entered. This request is no longer displayed once the personal code is entered.

**It is important to remember the personal code because:**

- the vehicle can be started if the immobilizer system is faulty

- the dashboard need not be replaced should the ignition switch be changed
- new keys can be programmed

#### NOTE

IF THE PERSONA CODE IS NOT MEMORISED AND THE VEHICLE IS USED, THE MESSAGE DISAPPEARS AFTER 10 SECONDS BUT REAPPEARS WITH EACH KEY ON.

#### NOTE

THE FACTORY SET CODE IS COMPOSED OF FIVE ZEROES.

### Light unit (02\_06)

#### Key:

1. MI warning light, orange.
2. High beam indicator light, blue.
3. ABS warning light, orange.
4. Turn indicator warning light, green.
5. Overspeed threshold/shift light indicator lights, white/orange/red.
6. Immobilizer indicator light, red
7. ATC indicator light, orange.
8. General warning light, red
9. Side stand warning light, orange.
10. Low fuel warning light, orange.



### Digital lcd display (02\_07, 02\_08, 02\_09, 02\_10, 02\_11, 02\_12)

#### NOTE

THE DASHBOARD IS PROVIDED WITH A TWILIGHT SENSOR THAT, BASED ON THE AMBIENT LIGHTING, CAN PASS FROM DAYLIGHT MODE TO NIGHT TIME

## MODE, CHANGING THE COLOUR OF THE BACKGROUND WHEN "AUTO" (AUTOMATIC) MODE IS SET IN THE ADVANCED FUNCTIONS.

- Turning the ignition switch to 'KEY ON', the following illuminate on the dashboard for about two seconds:
  - A dynamic graphic presentation.
  - All indicator lights on.

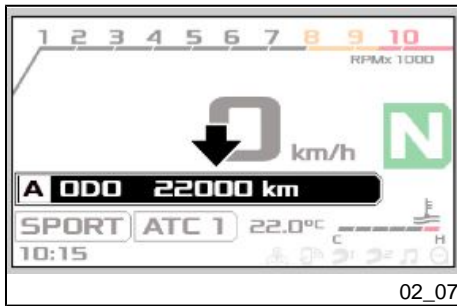

Using the MODE selector it is possible to move between the various information available in the "trip journal".

Slight pressure in the centre of the MODE selector when set to the ABS (only with the vehicle at a standstill) and ATC (with the engine running, IF APPLICABLE) function will allow you to edit the selected function changing the background colour to red.

Then, moving the MODE selector left or right, it will be possible to change the intervention value (in the ABS function it will be able to disable the system, while in the ATC function it will be possible to change the intervention level or deactivate the system, represented by the "-" symbol).

Pressing the centre of the MODE selector again confirms the value selected and returns you to the trip journal.



The following information can be seen in the digital display

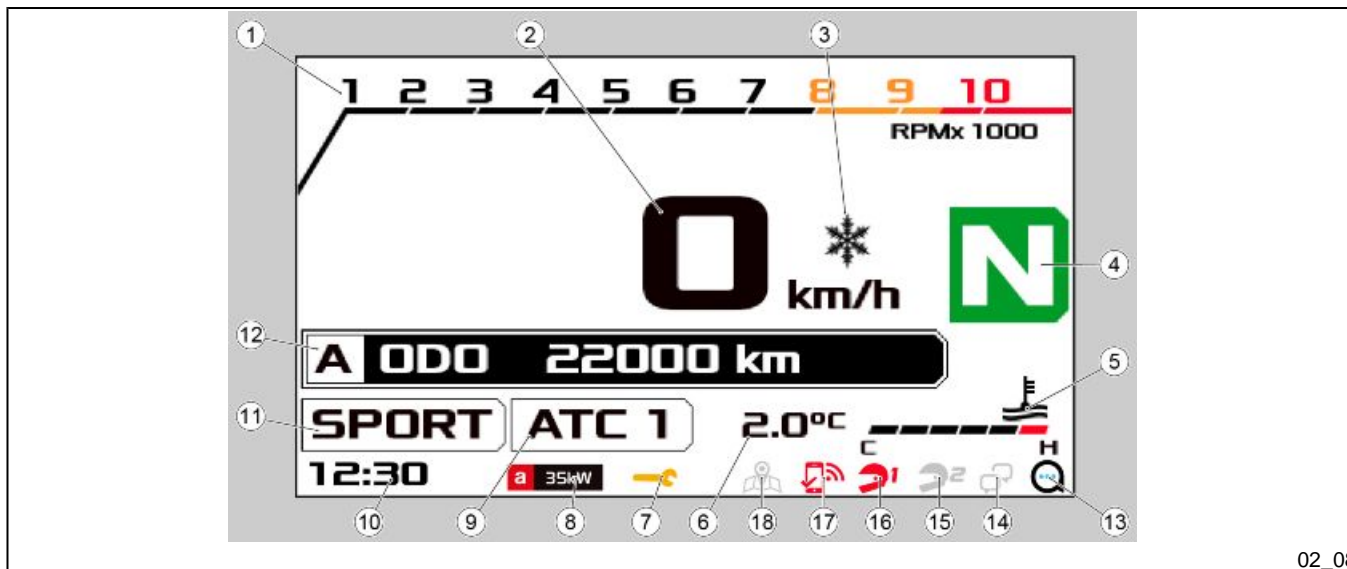

02\_08

**Key:**

- 1) Engine revs (rpm x 1000).
- 2) Speed (speedometer) (displayed in km/h or in mph).
- 3) Ice alert indicator (ambient temperature below 3 °C (37.4 F°))
- 4) Gear engaged.

- 5) Water temperature measurement.
- 6) Ambient temperature (Can be displayed in C° or in F°)
- 7) Maintenance icon.
- 8) Presence of underpowered map indicator (35kW).
- 9) ATC (Aprilia Traction Control) (intervention level).
- 10) Clock (can be displayed both in 24H mode, as well as 12H mode without AM / PM indicated)
- 11) Selected map.

12) Journal of the trip computer.

**Where the AMP control unit is present (accessory):**

- 13) Data transmission with smartphone present/not present
- 14) Intercom active/deactivated
- 15) Passenger headset connected/disconnected
- 16) Rider headset connected/disconnected
- 17) Audio transmission with smartphone for calling, sending vocal commands and playing music; Present/Not present
- 18) GPS/Navigator (where active) activated/deactivated



Two kilometres (1.24 mi) after the fuel reserve warning light is switched on, the number of kilometres travelled on reserve appears on the digital display.

When the low fuel warning light is on, it can be made to turn off and then back on again after 60 seconds by pressing the MODE selector's central button.

At "KEY-ON" the indication of reserve can have a delay of 60 seconds.



When a maintenance interval threshold is exceeded (except for the first one), a spanner symbol flashes for 5 seconds on the display.

This indicator may be reset once the scheduled service has been completed by an **authorised Aprilia Dealer or service centre**.

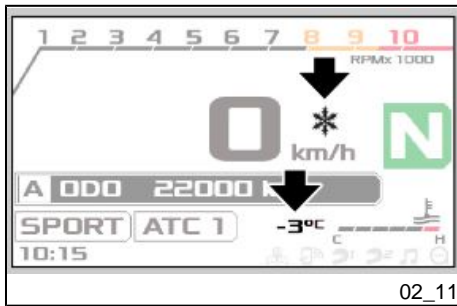

When the outside temperature is lower than or equal to 3 °C (37.4 °F), the ice alarm symbol is displayed.

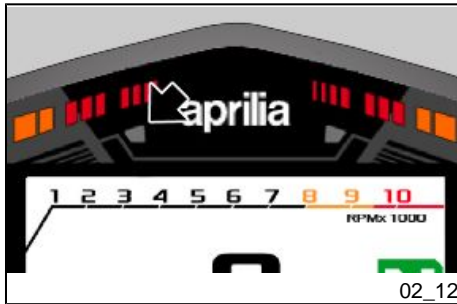

With the key set to "KEY OFF" the general alarm warning light flashes to indicate activation of the locking system. To reduce battery consumption the light stops flashing after about 48 hours.

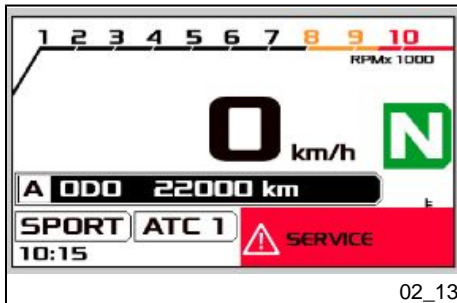

### Alarms (02\_13, 02\_14, 02\_15, 02\_16, 02\_17, 02\_18)

In the event of a fault, the digital display will show the cause.

Take your vehicle as soon as possible to an Authorised **Aprilia** Dealer.

#### SERVICE ALARM

In case of failure found in the dashboard or in the electronic control unit, the dashboard signals the failure by displaying the word SERVICE and the red general warning light turns on.

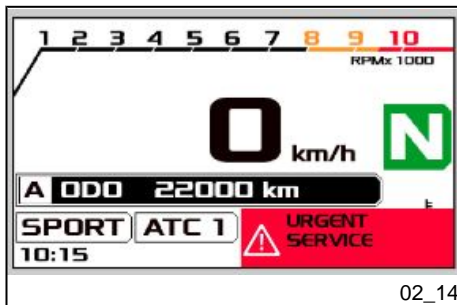

If there is an immobilizer failure at ignition, the dashboard requests you to enter a user code. If the code is entered correctly, the dashboard signals the failure by displaying the word SERVICE and the red general warning light turns on.

### URGENT SERVICE ALARM

A serious failure is signalled by a fast flashing (two flashes per second) of the general warning light and by the words URGENT SERVICE on the digital display. Take your vehicle as soon as possible to an Official **Aprilia** Dealer. In these cases, the control unit activates a safety procedure that limits the vehicle performance so that the rider is able to reach an Official **Aprilia** Dealer at low speed. Depending on the type of failure, performance can be limited in three ways: a) by reducing the maximum torque produced; b) by keeping the engine at idle speed but slightly accelerated (during this operation, the throttle control is disabled); c) the engine rpm is steady at around 3000 rpm; Under these conditions the throttle control provides limited management of the torque.

### NOTE

**THE PRESENCE OF THE "URGENT SERVICE" ERROR ON THE DIGITAL DISPLAY AND ACCOMPANIED BY THE FLASHING OF THE FOUR ARROWS TO WARN THE VEHICLES FOLLOWING OF A POSSIBLE DANGEROUS SITUATION, UNTIL THE TURN INDICATOR IS ACTIVATED TO ALLOW THE DRIVER TO PULL OVER .**

### Oil failure

If any oil pressure anomaly is detected, the digital display views the text "ALARM OIL PRESSURE".

### CAUTION

**THE SIGNAL IS ACCOMPANIED BY THE RED GENERAL WARNING LIGHT FLASHING.**



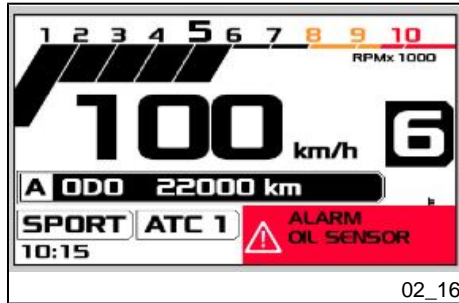

**STOP THE VEHICLE AND IMMEDIATELY CONTACT AN Approved Aprilia Dealer.**

If any oil pressure sensor anomaly is detected, the digital display views the text "ALARM OIL SENSOR"

#### CAUTION

**THE SIGNAL IS ACCOMPANIED BY THE RED GENERAL WARNING LIGHT TURNING ON.**

#### CAUTION

**AS SOON AS POSSIBLE GO TO AN Authorised Aprilia Dealer.**

#### Engine overheating alarm

The engine overheating alarm is activated when the temperature reaches 115 °C (239 °F). This is indicated by the lighting up of the red general alarm indicator light and by the flashing of the temperature symbol and bar on the digital display.



#### Electronic control unit disconnected alarm

If there is no connection, the instrument panel signals the fault by displaying "ALARM CAN ECU DISCONNECTED" and lighting up the general alarm red warning light.

#### NOTE

**THE PRESENCE OF THE "ALARM CAN ECU DISCONNECTED" ERROR ON THE DIGITAL DISPLAY AND ACCOMPANIED BY THE FLASHING OF THE FOUR ARROWS TO WARN THE VEHICLES FOLLOWING OF A POSSIBLE DANGEROUS**

SITUATION, UNTIL THE TURN INDICATOR IS ACTIVATED TO ALLOW THE DRIVER TO PULL OVER .

#### ATC alarm disabled

the alarm disabling the ATC system is activated when there is a problem that can cause the system itself to be disabled.

#### CAUTION

DRIVE CAREFULLY AND IMMEDIATELY CONTACT AN Official Aprilia Dealer



#### Mapping selection (02\_19)

The engine control unit has 3 different engine maps for managing the electronic accelerator, displayed as follows in the middle left part of the digital display:

- TOURING
- SPORT
- RAIN

The **TOURING** mode is designed for a tourism use of the vehicle.

The **SPORT** mode is the most reactive and is designed for a sport use of the vehicle.

#### CAUTION

**ONLY EXPERT RIDERS, RIDING ON ROADS WITH GOOD GRIP ARE ADVISED TO USE THIS MODE. IT IS NOT RECOMMENDED FOR WET SURFACES AND/OR ROADS WITH LOW GRIP.**

The **RAIN** mode is designed for use of the vehicle on wet surfaces or in conditions of poor grip. The system reduces the maximum torque supplied by the engine and

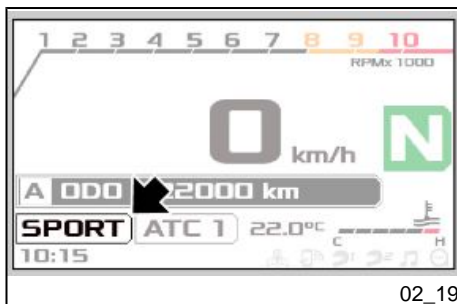

smoothly delivers it so as to prevent loss of grip. In this mode, the vehicle performance is limited, and therefore, the maximum speed cannot be reached.

**EVEN IN THIS MODE, ALWAYS USE PARTICULAR CAUTION WHEN RIDING IN POOR GRIP CONDITIONS.**

Passing through the various maps is carried out using the starter button that, 3 seconds after the engine has started, acquires the function of map selection Button.

**CAUTION**

**THE MAPPING SELECTION PROCEDURE IS ONLY ACTIVE WITH THE ENGINE RUNNING AND THE THROTTLE RELEASED. THIS PROCEDURE CAN ALSO BE CARRIED OUT WITH THE MOTORCYCLE MOVING AND THE THROTTLE RELEASED.**

**IT IS ALSO POSSIBLE TO CARRY OUT THE PROCEDURE ALSO WITH THE THROTTLE OPEN, BUT THE EFFECTIVE PASSAGE TO THE NEW MAPPING SELECTED WILL ONLY HAPPEN WHEN THE THROTTLE IS CLOSED.**

To change mappings, proceed as follows:

- pressing the button once, the symbol of the mapping currently applied will be flashing.
- pressing the button again within 1.5 seconds from the first time, the next mapping selected will be flashing. If the button is not pressed again within 1.5 seconds (which would select the next available map), and the throttle grip is not used, the new mapping selection is shown in a fixed manner on the display, indicating that the new mapping selection has been implemented.

**CAUTION**

**IF, WHILE THE NEW DESIRED MAPPING IS DISPLAYED IN A FLASHING MANNER (THEREFORE STILL IN THE PHASE OF BEING ACCEPTED BY THE CONTROL UNIT) THE THROTTLE IS USED, THE NEW MAP SELECTED WILL NOT BE EFFECTIVELY APPLIED UNTIL THE THROTTLE IS RELEASED.**



**IF THE PROCEDURE IS CARRIED OUT WITH THE THROTTLE OPEN, THE NEW MAP SELECTED WILL CONTINUE FLASHING UNTIL THE THROTTLE IS RELEASED.**

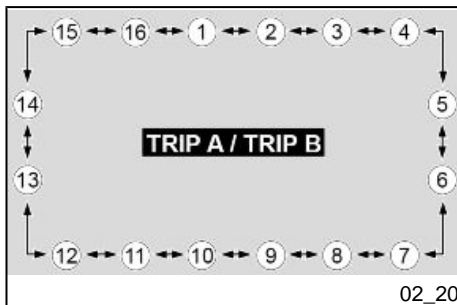

## Control buttons (02\_20)

### Trip journal A and B

In the space for displaying information of the trip computer, there are also some parameters that can be adjusted.

Using the MODE selector, you can consult the information in the two trip menus (A and B).

In each journal, every slight pressure on the MODE selector on the right or on the left displays in succession the following information:

- 1) ODOMETER.
- 2) PARTIAL ODOMETER "A".
- 3) TRAVELLING TIME "A".
- 4) MAXIMUM SPEED "A".
- 5) AVERAGE SPEED "A".
- 6) AVERAGE CONSUMPTION "A".
- 7) PARTIAL ODOMETER "B".
- 8) TRAVELLING TIME "B".
- 9) MAXIMUM SPEED "B".
- 10) AVERAGE SPEED "B".
- 11) AVERAGE CONSUMPTION "B".
- 12) INSTANT FUEL CONSUMPTION.

13) AVERAGE FUEL CONSUMPTION.

14) MENU.

15) ABS.

16) ATC.

With the following options: PARTIAL ODOMETER, TRAVELLING TIME, MAXIMUM SPEED, AVERAGE SPEED, AVERAGE FUEL CONSUMPTION pressing on and holding the centre of the "MODE" selector resets all the indications stored in the active TRIP JOURNAL.

The MENU and ABS functions can be edited only at speeds less than 5 km/h (3.1 mph).

The ATC function can also be edited with the vehicle moving.

**Advanced functions (02\_21, 02\_22, 02\_23, 02\_24, 02\_25, 02\_26, 02\_27, 02\_28, 02\_29, 02\_30, 02\_31, 02\_32, 02\_33, 02\_34, 02\_35, 02\_36, 02\_37, 02\_38, 02\_39, 02\_40, 02\_41, 02\_42, 02\_43, 02\_44, 02\_45, 02\_46, 02\_47, 02\_48, 02\_49, 02\_50, 02\_51, 02\_52, 02\_53, 02\_54, 02\_55, 02\_56, 02\_57, 02\_58, 02\_59, 02\_60, 02\_61, 02\_62, 02\_63, 02\_64, 02\_65, 02\_66, 02\_67, 02\_68, 02\_69, 02\_70)**

Some functions in the trip computer can be modified and in their turn have sub-menus

#### **ATC (Aprilia Traction Control)**

##### **NOTE**

**IF APPLICABLE, THE ATC INTERVENTION LEVEL MAY ONLY BE MODIFIED WHEN THE ENGINE IS RUNNING.**

**NOTE**

**IT IS POSSIBLE TO CHANGE THE ATC LEVEL ALSO WHEN THE VEHICLE IS MOVING.**

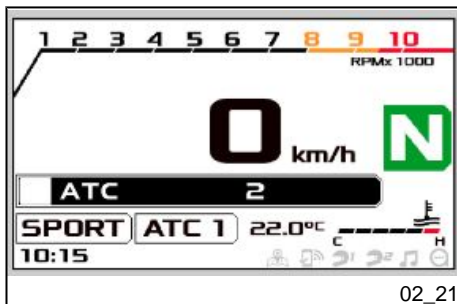

To edit and as a result modify the value of the selected function, briefly press or shift the MODE selector in the middle. The background of the selected function will be red.

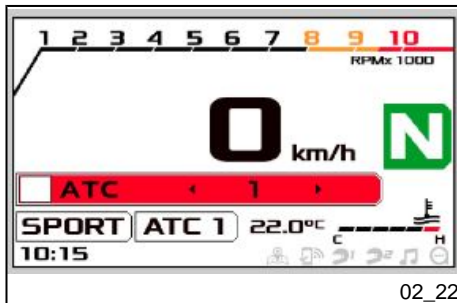

Moving to the left or to the right it is possible to change the intervention value of the ATC system.

To return to the "ATC" menu, press the MODE selector in the middle.

**NOTE**

**TO DEACTIVATE THE ATC SYSTEM, FROM LEVEL "1", MOVE THE MODE SELECTOR TO THE LEFT TO DISPLAY THE SYMBOL "-". VICE-VERSA, TO REACTIVATE THE SYSTEM FROM THE VALUE "-", MOVE THE MODE SELECTOR TO THE RIGHT.**

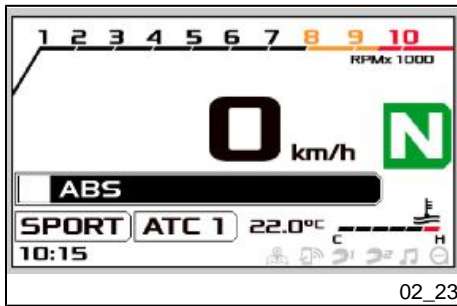

## ABS

To edit and as a result modify the value of the selected function (only with the vehicle at a standstill), briefly press the MODE selector in the middle. The background of the selected function will be red.

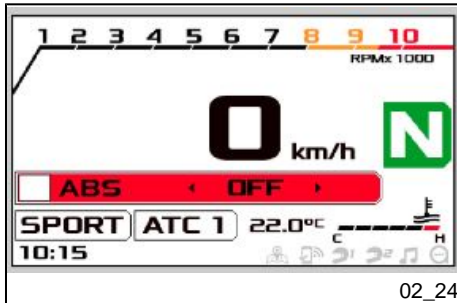

Moving briefly to the left or to the right it is possible to deactivate or reactivate the ABS system.

To return to the "ABS" menu, briefly press the MODE selector in the middle.

## CAUTION

**IT IS DISABLED ONLY TEMPORARILY, WHEN THE KEY IS INSERTED THE SYSTEM IS ALWAYS ACTIVE.**

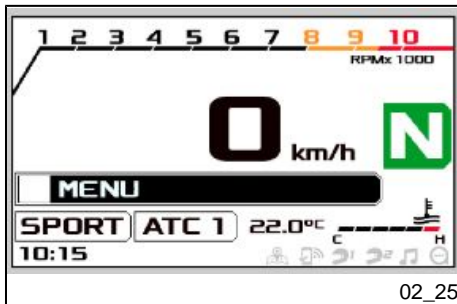

## MENU

After being selected, the configuration menu can be immediately accessed by briefly pressing the middle of the MODE selector.

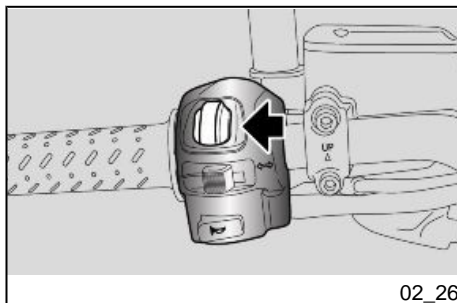

02\_26

MENU	
Riding mode	
Shift light	6500
Display	
Service	
Dashboard	
Exit	

02\_27

The menu is composed of the following entries:

- 1) Riding mode (Riding mode)
- 2) Shift light (Shift light)
- 3) Display
- 4) Service (Service)
- 5) Dashboard (Dashboard)
- 6) Exit (Exit)

RIDING MODE	
ABS	on
Calibration	
Bluetooth pairing	
Pairing reset	
Exit	

02\_28

### 1) Riding mode (Riding mode)

The "Riding mode" menu consists of the following:

- 1.1) ABS
- 1.2) Calibration (Calibration)
- 1.3) Bluetooth pairing
- 1.4) Pairing reset
- 1.5) EXIT (Exit)

The functions of the "Riding mode" menu are shown in the paragraphs below.

To return to the main "MENU", select "EXIT" on the menu and press the MODE selector briefly in the middle.

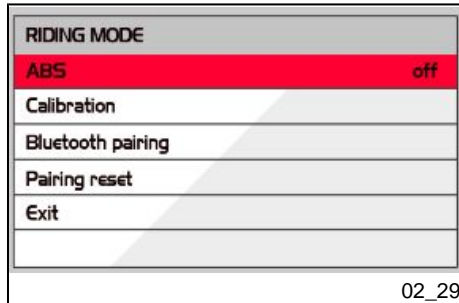

### 1.1) ABS

This function allows you to disable the ABS system that is normally active "On".

Lightly pressing the middle of the MODE selector highlights the "ABS" function in red. Briefly moving to left or right deactivates the function "Off".

To return to the main "MENU", select "EXIT" on the menu and press the MODE selector briefly in the middle.

#### CAUTION

**IT IS DISABLED ONLY TEMPORARILY, WHEN THE KEY IS INSERTED THE SYSTEM IS ALWAYS ACTIVE.**

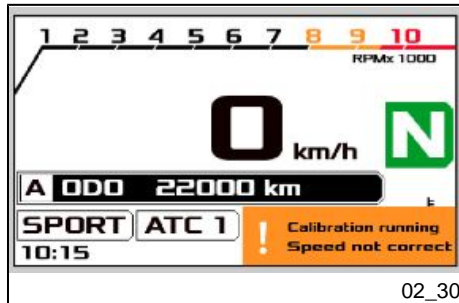

### 1.2) Calibration (Calibration)

When the Calibration function is selected (with the vehicle at a standstill), a screen appears with the following description in the bottom left of the display:

**CALIBRATION RUNNING SPEED NOT CORRECT**

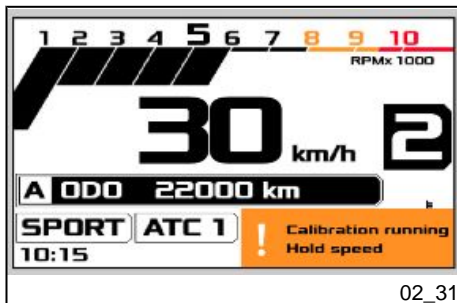

02\_31

To calibrate the a-PRC system (Aprilia Performance Ride Control) ride along a flat straight road in second gear at a speed of 30 +/- 2 km/h (18.64 +/- 1.24 mph) for about 10 seconds, accompanied by the **CALIBRATION RUNNING HOLD SPEED** screen.

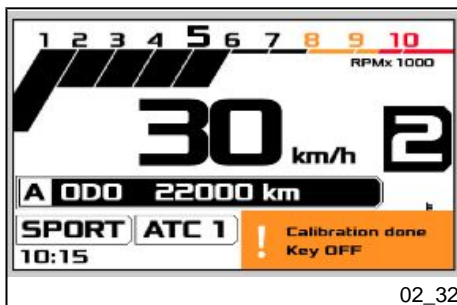

02\_32

#### NOTE

WHEN THE MESSAGE "CALIBRATION DONE KEY OFF" APPEARS, STOP THE VEHICLE, TURN THE IGNITION SWITCH OFF AND WAIT AT LEAST 60 SECONDS TO ALLOW THE CALIBRATION PROCEDURE TO COMPLETE CORRECTLY.

THIS ALLOWS THE CALIBRATION TO BE STORED IN THE MEMORY.

#### NOTE

THE CALIBRATION PROCEDURE IS USED TO OPTIMISE a-PRC FUNCTIONALITY IN THE EVENT OF CHANGING TYRE TYPE OR FINAL DRIVE RATIO (PINION-SPROCKET COMBINATION).

IF THE VEHICLE IS FITTED WITH TYRES OTHER THAN THOSE INDICATED IN THIS USE AND MAINTENANCE MANUAL, THE LEVEL SETTINGS OF THE SYSTEM MAY NEED TO BE MODIFIED IN ORDER TO OBTAIN THE SAME BEHAVIOUR AS BEFORE.

#### NOTE

TURN THE IGNITION SWITCH OFF TO ABORT THE CALIBRATION PROCEDURE.

WHEN CARRYING OUT THE CALIBRATION, THE ATC IS AUTOMATICALLY DEACTIVATED (IF PREVIOUSLY ACTIVATED) AND REMAINS DEACTIVATED UNTIL THE NEXT KEY ON.

If the calibration procedure does not end well, the "**CALIBRATION RUNNING SPEED NON CORRECT**" screen is displayed

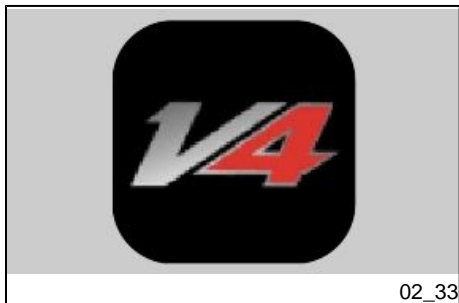

### 1.3) Bluetooth pairing (where required)

The vehicle is equipped with the «**APRILIA MIA**» ECU which communicates with the smartphone via Bluetooth. Using the special "**APRILIA**" application installed on the smartphone, it is possible to exchange data with the vehicle and manage multimedia contents. Once a connection is established correctly between the ECU and the smartphone, the following functions are accessible and controllable directly from the digital display of the vehicle:

- manage phone calls;
- manage audio playback;
- GPS navigation.

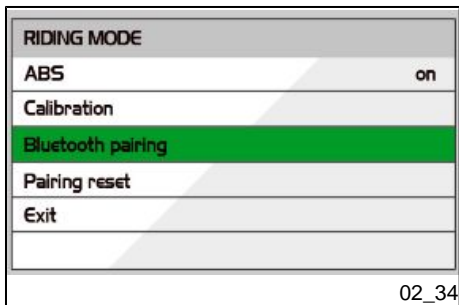

Highlight the "**Bluetooth pairing**" function and briefly press the MODE selector centrally.



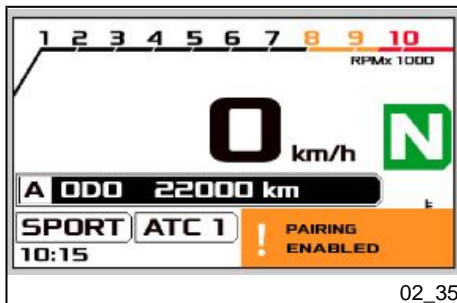

The message confirming that pairing with the smartphone is enabled appears on the digital display. Enable the bluetooth search on your smartphone, select the "BT-ROUTER" device, if required, enter the password "0000" and press on pair.

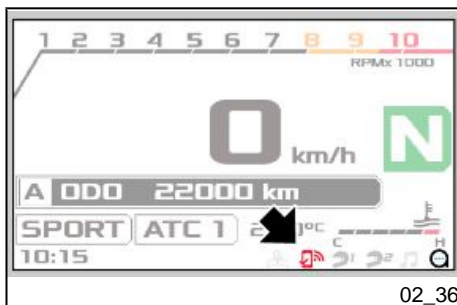

The "BT-ROUTER" device will be visible in the list of associated devices on the smartphone. Wait for the digital display to automatically connect the smartphone. **DO NOT force the connection from the phone.** The smartphone icon on the display indicates communication is active. **Allow sharing of the phonebook and notifications when requested. These enabling operations are necessary to display the caller's name on the display.**

#### NOTE

**A PROLONGED TIME FOR THE SYNCHRONIZATION OF THE PHONEBOOK MAY BE NECESSARY FOR THE FIRST PAIRING BETWEEN THE DISPLAY AND THE SMARTPHONE.**

**THE CONNECTION BETWEEN THE SMARTPHONE AND VEHICLE WILL BE SIGNALLIED BY THE LIGHTING OF THE SMARTPHONE ICON ON THE DISPLAY.**

#### CONNECTION BETWEEN THE APPLICATION AND THE DIGITAL DISPLAY

Search for the «APRILIA» application from the Play Store or App Store, and install it. Register your account by following the instructions. Select "allow" for the position and notifications management requests.

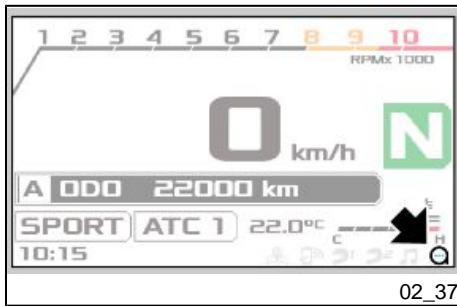

Open the "APRILIA" application on your smartphone and log in with your account. On the main page of the application select "Connect". Select the model of your vehicle, the icon of the "APRILIA" app appears on the digital display confirming the activation of the communication between App and Shiver.

### PAIRING OF BLUETOOTH HEADSET

You can use the multimedia functions via the MODE selector, pairing a bluetooth headset with the digital display through the "APRILIA" application. After pairing it will be possible to answer or reject calls, activate voice commands and control the music on the smartphone.

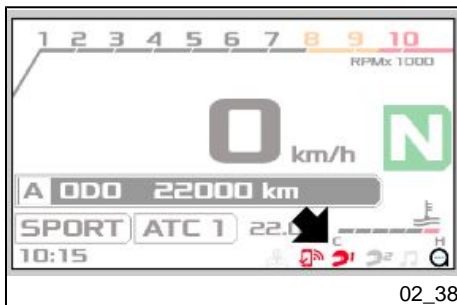

Activate the "pairing" mode of the bluetooth headset to be paired (refer to the instructions of the device itself). Press the Bluetooth icon on the main screen of the "APRILIA" application and perform a new search for devices until the headset is displayed. Select the bluetooth headset, check the "Handsfree/driver headset" option and press "Pair". Successful pairing is indicated by the helmet icon displayed on the digital display. If pairing is not successful, carry out a new search.

Repeat the operation to connect a second device also. In this case, if the operation is successful, the helmet icon number 2 will be highlighted in red on the digital display.



02\_39

No multimedia function will be controllable from the handlebar of the vehicle in the absence of a bluetooth headset, or in the event the headset is directly connected to the smartphone. **The pairing of the bluetooth headset to the vehicle is only possible via the "APRILIA" application and this must be connected to the vehicle in order to correctly use the multimedia functions of the system. For this reason, headsets that automatically connect to the smartphone are not compatible (e.g: Apple Airpod).**

**If pairing between Smartphone and Vehicle is not successful, proceed as follows:**

- restart the smartphone;
- turn the ignition key to "**OFF**" and then to **ON**"; wait for the animation on the display to end.

If the smartphone icon on the display is not illuminated after approximately 1 minute, proceed as follows;

- open "**APRILIA**" and select "**Connect**";
- select your vehicle from the list of suggestions and follow the instructions on the device;
- once the Application is connected, select the Bluetooth icon that appears on the main screen;
- open the Bluetooth devices menu;
- select "**Configure**" and delete all paired devices, leaving the current device as the last one;
- make sure that the application icon on the display is off;
- turn the ignition key to "**OFF**" and then to "**ON**", then wait until the animation on the screen ends;
- the display must show the pop up "**No connected device**";
- repeat the pairing procedure from the start.

**NOTE**

**PLEASE NOTE THAT TO CONNECT THE APP TO THE VEHICLE AGAIN IT WILL BE NECESSARY TO:**

- **ON iOS, CANCEL THE APP PREVIOUSLY INSTALLED AND INSTALL IT AGAIN.**
- **ON ANDROID, SIMPLY DELETE THE APPLICATION DATA FROM THE APP MANAGEMENT MENU (THIS WILL RETURN THE APPLICATION TO THE INITIAL CONDITION AND THE LOGIN AND FIRST CONNECTION TO THE VEHICLE MUST BE PERFORMED AGAIN).**
- **IF CONNECTING TO A NEW VEHICLE, IT IS NECESSARY TO REMOVE THE PREVIOUS BT-ROUTER FROM THE PAIRED DEVICES.**

**NOTE**

**IT IS RECOMMENDED TO PAIR A MAXIMUM OF 2 SMARTPHONES AND 2 HEADSETS TO THE SAME VEHICLE, TO OPTIMIZE THE OPERATION OF THE SYSTEM.**

**WHEN CONNECTING THE SECOND SMARTPHONE, PLEASE NOTE THAT THE NEXT ONE WILL REQUIRE A LONGER TIME (MORE THAN 30 SECONDS) TO CONNECT TO THE "BT-ROUTER". ONCE THE SMARTPHONE IS CONNECTED TO THE "BT-ROUTER", THE OPERATING SYSTEM WILL REQUEST ACCESS TO THE PHONE BOOK AND TO THE NOTIFICATIONS; ACCEPT TO DISPLAY THE NAMES OF THE CALLERS ON THE DISPLAY.**

**Mandatory operation in iOS 10.0 versions and higher**

If the "**BT-ROUTER**" device does not automatically request permission to share notifications, the following procedure is necessary:

- enter the menu: "Settings" > "Bluetooth" > "Phone devices";
- select "**BT-ROUTER**", select "Info", enable the options manually.

**INTERCOM AND VOCAL COMMANDS MANAGEMENT**

The "APRILIA MIA" system manages the connection between intercom / smartphone upon activation by the user.



**FOR SAFETY REASONS, IT IS RECOMMENDED TO CARRY OUT THE ACTIVATION / DEACTIVATION PROCEDURES WITH THE VEHICLE AT A STANDSTILL.**

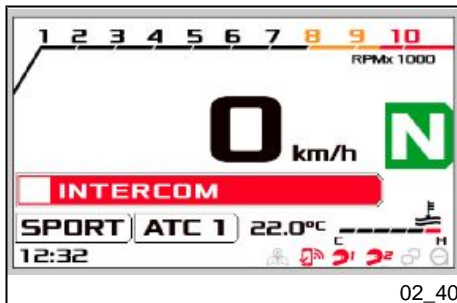

02\_40

To perform this operation, from the main screen, press and hold the MODE selector to the left.

The space dedicated to the trip time display will be highlighted in red and the word "INTERCOM" will be shown. By pressing briefly to the left or right allows the "INTERCOM / VOICE" functions to be displayed cyclically.

To activate the highlighted function, press the MODE selector briefly.

#### CAUTION

**WHEN THE NAVIGATION SCREEN IS DISPLAYED, THE COMMAND TO ACTIVATE THE "INTERCOM / VOICE" FUNCTIONS DETERMINES THE MAIN SCREEN DISPLAY.**

**ONCE THE COMMAND SELECTION COMPLETED, THE DISPLAY RETURNS TO THE NAVIGATION SCREEN.**

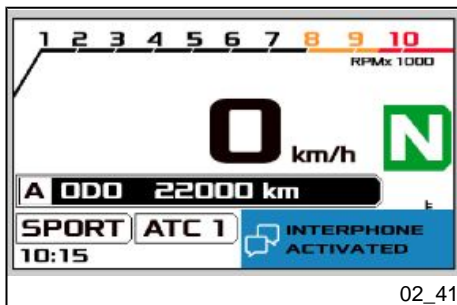

02\_41

An "INTERPHONE ACTIVATED" pop-up will be shown for a limited time on the digital display.

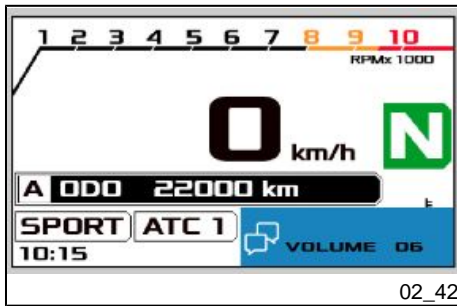

Subsequently, the sound level can be adjusted using the MODE selector, before the pop-up disappears.

At this point, the "interphone" icon will switch on.

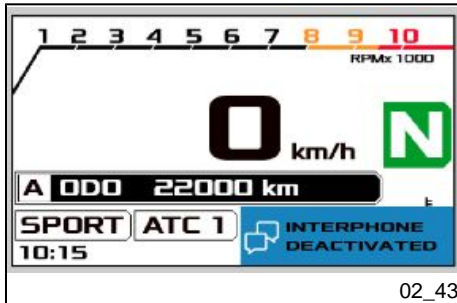

By selecting the 'INTERCOM' function again, the connection will be deactivated and the digital display will show the "INTERPHONE DEACTIVATED" message.



The "VOICE" function allows using the smartphone by giving voice commands via the handset (e. g. Siri or Google Assistant)

To activate the "VOICE" function, follow the previously described steps.



**THE "VOICE" FUNCTION CANNOT BE ACTIVATED IF THE "INTERCOM" FUNCTION IS ALREADY ACTIVATED.**

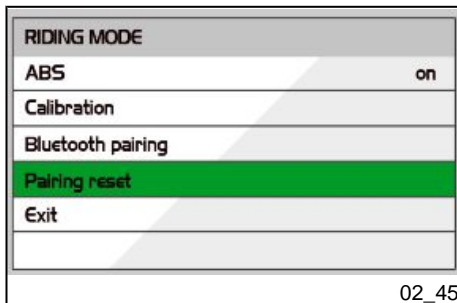

#### 1.4) Pairing reset

If you need to unpair your smartphone, proceed as follows. Highlight the "Pairing reset" function and briefly press the MODE selector centrally.

#### NOTE

**THIS OPERATION MUST BE PERFORMED WHEN YOU HAVE TO REPLACE THE SMARTPHONE.**

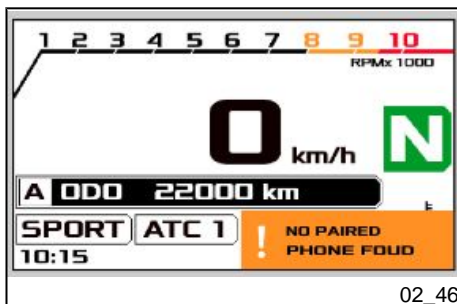

All stored Bluetooth devices are deleted from the "APRILIA MIA" system. The message confirming the cancellation is displayed on the digital display. You can repeat the procedure to pair the new smartphone.

#### NOTE

**PERFORM A KEY OFF/ON TO VALIDATE THE OPERATION. UPON KEY ON, THE MESSAGE "NO PAIRED PHONES FOUND" WILL BE SHOWN (TELEPHONE NOT PAIRED).**

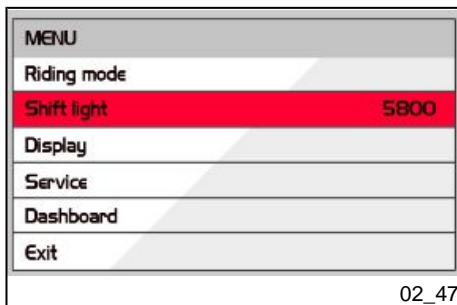

#### 2) Shift light (Shift light)

This function allows you to change the standard value of the pre-set shift light threshold when the relative LED will come on when it is exceeded.

Lightly pressing the middle of the MODE selector highlights the "Shift light" function in red. Briefly shifting the MODE selector to the left or right it is possible to increase or decrease the pre-set value.

Press the MODE selector in the middle to confirm the value entered.

To return to the main "MENU", select "EXIT" on the menu and press the MODE selector briefly in the middle.

DISPLAY	
Backlight	10
Mode	AUTO
Exit	
	02_48

### 3) Display

The "Display" menu consists of the following:

3.1) Backlight (Backlight)

3.2) Mode (Mode)

3.3) EXIT (Exit)

The functions of the "Display" menu are shown in the paragraphs below.

To return to the main "MENU", select "EXIT" on the menu and press the MODE selector briefly in the middle.

DISPLAY	
Backlight	7
Mode	AUTO
Exit	
	02_49

#### 3.1) Backlight (Backlight)

This function allows you to change the backlight of the digital display, from a minimum value of 1 to a maximum value of 10.

Lightly pressing the middle of the MODE selector highlights the "Backlight" function in red. Briefly moving the MODE selector to the left or right, the intensity of the backlight increase or decreases.

Pressing the MODE selector again confirms the value selected and exits the modification function.

To return to the main "MENU", select "EXIT" on the menu and press the MODE selector briefly in the middle.



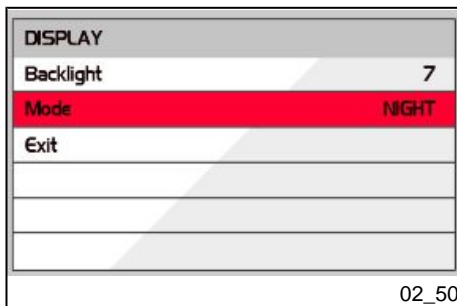

### 3.2) Mode (Mode)

This function allows you to change the display mode of the digital display:

- AUTO.
- DAY (Day).
- NIGHT (Night).

Lightly pressing the middle of the MODE selector highlights the "Mode" function in red. Briefly shifting the MODE selector to the left or right, it is possible to select the preferred mode.

Pressing the MODE selector again confirms the selection and exits the modification function.

To return to the main "MENU", select "EXIT" on the menu and press the MODE selector briefly in the middle.

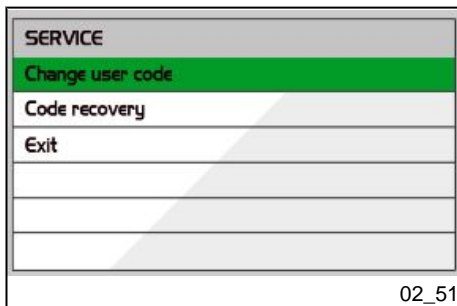

### 4) Service (Service)

The "Service" menu consists of the following:

- 4.1) Change user code (Change user code)
- 4.2) Code recovery (Code recovery)
- 4.3) EXIT (Exit)

The functions of the "Service" menu are shown in the paragraphs below.

To return to the main "MENU", select "EXIT" on the menu and press the MODE selector briefly in the middle.



#### 4.1) Change user code (Change user code)

This function may be used to modify the existing code (you must be in possession of the code itself in order to do this). The user code enables engine start even in the event of an immobiliser system fault. The user code is set by default as five zeros (00000) on a new vehicle, and the message "INSERT CODE" is shown on the display for ten seconds.

This function allows you to change the code itself and remove this message.

On the value furthest left on the display values from 0 to 9 will be displayed cyclically. Confirm the selection by shifting the MODE selector until the five numbers are complete. Once the code is confirmed, the new code is shown steadily on the display to let the user verify that the code has been entered correctly. Turn the ignition off and then on again to unlock the dashboard. The last code set may be modified again in future. Access the setting mode again, enter the last user code used (OLD CODE), then enter a new user code (NEW CODE) as described previously.

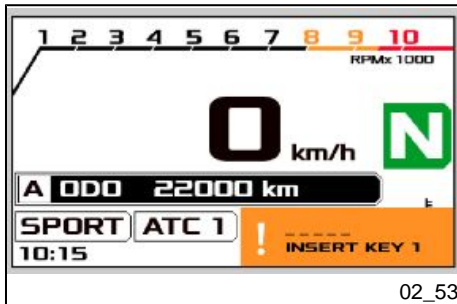

#### 4.2) Code recovery (Code recovery)

This function must be used should it be necessary to change the user code when the user no longer remembers the current code. Both keys stored in the vehicle memory are needed to access this function.

When the function is activated, by pressing briefly on the middle of the MODE selector, the screen "INSERT KEY 1" is displayed to signal the recognition request of the first key. Insert the key. If the correct key is recognised within twenty seconds, the message "INSERT KEY 2" is shown on the display. Insert the second key. If the second key is also recognised within twenty seconds, the dashboard resets the user code to the default code (five zeros - 00000). Enter the new user code following the "CHANGE USER CODE " procedure.

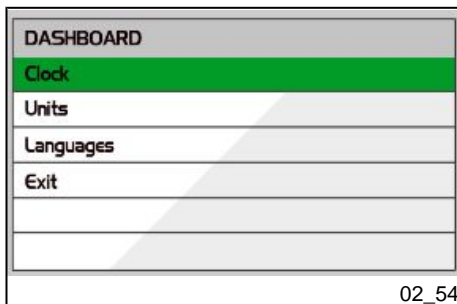

## 5) Dashboard (Dashboard)

The "Configuration" menu is composed of the following entries:

- 5.1) Clock (Clock)
- 5.2) Units (Units)
- 5.3) Languages (Languages)
- 5.3) EXIT (Exit)

The functions of the "Dashboard" menu are shown in the paragraphs below.

To return to the main "MENU", select "EXIT" on the menu and press the MODE selector briefly in the middle.

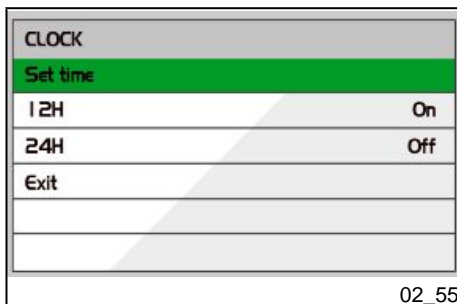

## 5.1) Clock (Clock)

The "Clock" menu is composed of the following:

- 5.1.1) Set time (Set time)
- 5.1.2) 12H
- 5.1.3) 24H
- 5.3) EXIT (Exit)

The functions of the "Clock" menu are shown in the paragraphs below.

To return to the "Dashboard" menu, select "EXIT" on the menu and press the MODE selector briefly in the middle.

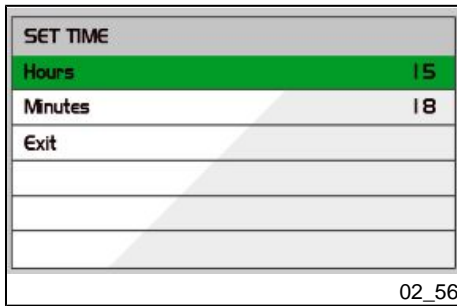

### 5.1.1) Set time (Set time)

This menu allows you to set the clock and is divided in turn into the following entries:

5.1.1.1) Hours (Hours)

5.1.1.2) Minutes (Minutes)

5.1.1.3) Exit (Exit)

The functions of the "Set time" menu are shown in the paragraphs below.

To return to the "Clock" menu, select "EXIT" on the menu and press the MODE selector briefly in the middle.

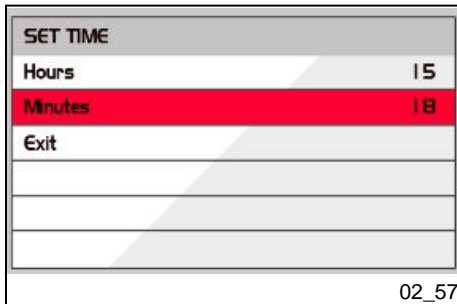

### 5.1.1.1) Hours (Hours) / 5.1.1.2) Minutes (Minutes)

To edit and as a result modify the value of one of the two selected functions, briefly press the MODE selector in the middle. The background of the selected function will be red.

Moving to the left or to the right it is possible to change its value.

To exit the modification function, briefly press the MODE selector.

To return to the "Clock" menu, select "EXIT" on the menu and press the MODE selector briefly in the middle.

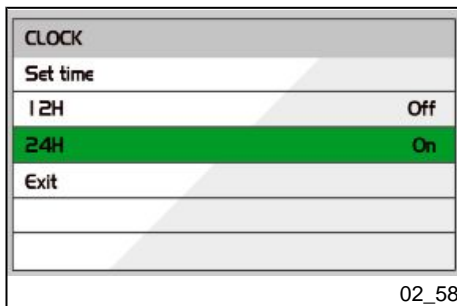

### 5.1.2) 12H / 5.1.3) 24H

To render active (ON) the time display format, 12H or 24H, briefly press the middle of the MODE selector at the format desired.

To return to the "Dashboard" menu, select "EXIT" on the menu and press the MODE selector briefly in the middle.

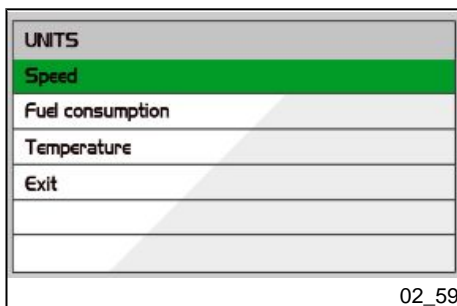

### 5.2) Units (Units)

This menu allows you to change the settings for displaying the units and is divided as follows:

5.2.1) Speed (Speed)

5.2.2) Fuel consumption (Fuel consumption)

5.2.3) Temperature (Temperature)

5.2.4) Exit (Exit)

To return to the "Dashboard" menu, select "EXIT" on the menu and press the MODE selector briefly in the middle.

SPEED	
km/h	On
MPH	Off
Exit	

02\_60

### 5.2.1) Speed (Speed)

To render active (ON) the desired units, expressed in km/h or in MPH, select the unit and briefly press the MODE selector in the middle.

To return to the "Units", select "EXIT" on the menu and press the MODE selector briefly in the middle.

#### NOTE

**IF THE UNIT OF MEASURE SET AT THE FACTORY HAS BEEN CHANGED, THE SPEED'S UNIT OF MEASURE WILL FLASH FOR 30 SECONDS EACH TIME THE KEY IS ENGAGED.**

FUEL CONSUMPTION	
km/l	On
l/100km	Off
MPG (UK)	Off
MPG (USA)	Off

02\_61

### 5.2.2) Fuel consumption (Fuel consumption)

To render active (ON) the desired units, regarding fuel consumption, briefly press the MODE selector in the middle.

To return to the "Units", select "EXIT" on the menu and press the MODE selector briefly in the middle.

TEMPERATURE	
'C	On
'F	Off
Exit	

02\_62

### 5.2.3) Temperature (Temperature)

To render active (ON) the desired units, regarding ambient temperature, briefly press the MODE selector in the middle at the desired value.

To return to the "Units", select "EXIT" on the menu and press the MODE selector briefly in the middle.

LANGUAGES	
Italiano	On
English	Off
Français	Off
Deutsch	Off
Español	Off
Exit	

02\_63

### 5.3) Languages (Languages)

This menu allows you to set the display language of the dashboard.

To render active (ON) the desired language, briefly press the MODE selector in the middle.

To return to the "Units", select "EXIT" on the menu and press the MODE selector briefly in the middle.

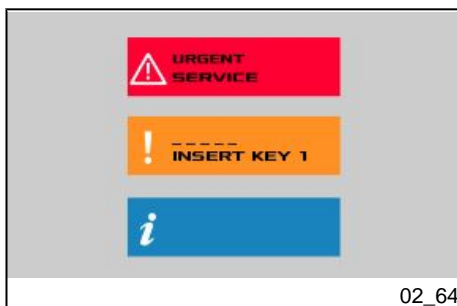

### «APRILIA MIA» SYSTEM MESSAGES

The «APRILIA MIA» system communicates with the user through messages that can be viewed on the graphic panel of the digital display. Depending on the type of message, the graphic panel shows icon, colours and specific message. The image opposite displays:

- Text alarms, contact an **Authorised Service Centre**;
- Warning messages;
- Info messages.

### NOTE

**THE MODE SELECTOR COMMANDS ARE IGNORED WHEN A POPUP IS PRESENT ON THE DISPLAY. TO RESTORE THE STANDARD USE, IT IS NECESSARY TO REMOVE THE POPUP FROM THE DISPLAY FIRST.**

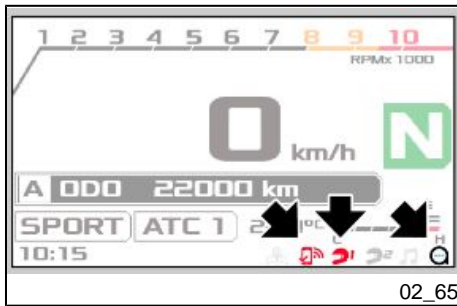

## CALL MANAGEMENT

To use call functions, view notifications and identifications of the caller, you need to:

- pair the smartphone with the "APRILIA MIA" system via bluetooth as described above;
- install and access with your account the "APRILIA" application on the smartphone;
- pair a bluetooth headset to the "APRILIA MIA" system via the «APRILIA» application;
- allow sharing of the phonebook and notifications when the smartphone is paired with the "APRILIA MIA" system.
- The relative three icons will appear on the digital display. Please note that on iOS systems the message notifications will be displayed **ONLY** at the second connection of the smartphone to the vehicle.

## NOTE

**WHEN A SMARTPHONE CONNECTS WITH THE «APRILIA MIA» SYSTEM (BT-ROUTER), AUDIO IS AUTOMATICALLY ROUTED TO THE APRILIA MIA SYSTEM. IF A HEADSET IS NOT CONNECTED TO THE "APRILIA MIA" SYSTEM YOU CAN NOT MANAGE THE AUDIO OF CALLS OR LISTEN TO MUSIC, THEREFORE YOU NEED TO MANUALLY DIRECT THE AUDIO OF YOUR SMARTPHONE TOWARDS THE DESIRED DEVICE (e.g. SPEAKERS / MICROPHONE OF THE SMARTPHONE).**

The information on the digital display are:

- call in progress;
- call ended;
- voice control active.

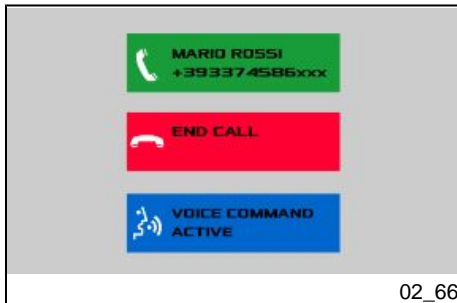



## **MODE SELECTOR FUNCTIONS FOR CALL MANAGEMENT**

Accept incoming call	PRESS CENTRE BUTTON OF SELECTOR BRIEFLY
End an active call	PRESS AND HOLD CENTRE BUTTON OF SELECTOR
Reject incoming call	PRESS AND HOLD CENTRE BUTTON OF SELECTOR
Cancel outgoing call	PRESS AND HOLD CENTRE BUTTON OF SELECTOR
Clear most recent missed call popup (with NO call in progress)	PRESS CENTRE BUTTON OF SELECTOR BRIEFLY
Redial last missed call number (with NO call in progress)	PRESS AND HOLD CENTRE BUTTON OF SELECTOR
Increase volume (with call in progress)	BRIEF SELECTOR PRESS TO THE RIGHT
Lower volume (with call in progress)	BRIEF SELECTOR PRESS TO THE LEFT

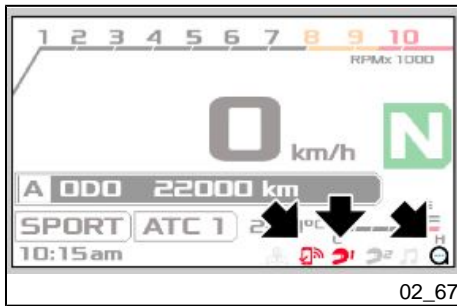

02\_67

## MANAGEMENT OF THE MUSIC PLAYBACK

To use the music playback functions, you need to:

- pair the smartphone with the "APRILIA MIA" system via bluetooth as described above;
- install and access with your account the "APRILIA" application on the smartphone;
- pair a bluetooth headset to the "APRILIA MIA" system via the «APRILIA» application.

The relative three icons will appear on the digital display.

### NOTE

**WHEN A SMARTPHONE CONNECTS WITH THE «APRILIA MIA» SYSTEM (BT-ROUTER), AUDIO IS AUTOMATICALLY ROUTED TO THE APRILIA MIA SYSTEM.**

**IF A HEADSET IS NOT CONNECTED TO THE "APRILIA MIA" SYSTEM YOU CAN NOT MANAGE THE AUDIO OF CALLS OR LISTEN TO MUSIC, THEREFORE YOU NEED TO MANUALLY DIRECT THE AUDIO OF YOUR SMARTPHONE TOWARDS THE DESIRED DEVICE (e.g. SPEAKERS / MICROPHONE OF THE SMARTPHONE).**

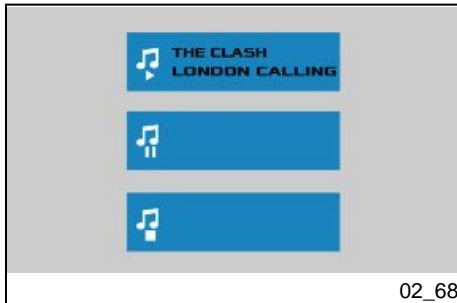

02\_68

The information on the digital display are:

- track playing;
- playback paused;
- playback interrupted.

Use the MODE selector to manage audio playback as shown in the table:

## **MODE SELECTOR FUNCTIONS FOR MUSIC MANAGEMENT**

Play track	PRESS CENTRE BUTTON OF SELECTOR BRIEFLY
Increase audio volume (with audio playback in progress)	BRIEF SELECTOR PRESS TO THE RIGHT
Lower audio volume (with audio playback in progress)	BRIEF SELECTOR PRESS TO THE LEFT
Next audio track	LONG SELECTOR PRESS TO THE RIGHT
Previous audio track	LONG SELECTOR PRESS TO THE LEFT
Play / pause	PRESS CENTRE BUTTON OF SELECTOR BRIEFLY
Exit audio playback mode	PRESS AND HOLD CENTRE BUTTON OF SELECTOR
Intercom activation (when music is NOT active)	LONG SELECTOR PRESS TO THE LEFT

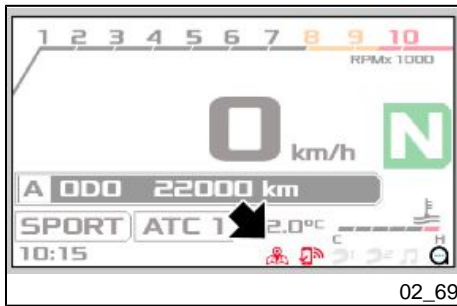

## GPS NAVIGATION

The "APRILIA MIA" system, paired with the "APRILIA" application, allows GPS indications to be shown on the digital display. The desired destination can be reached by means of pictograms, distance data and travel times.

Consult the navigation guide by accessing the "APRILIA" application with your account. The navigation icon appears on the digital display after setting the destination address.

By holding the MODE selector pressed to the RIGHT, the GPS indications screen is accessed.

### NOTE

**BY SETTING THE DESTINATION ADDRESS THROUGH THE "APRILIA" APPLICATION, THE DIGITAL DISPLAY AUTOMATICALLY DISPLAYS THE DIRECTIONS SCREEN.**

### NOTE

**"SHORT PRESS": PRESS THE BUTTON AND RELEASE WITHIN 0.5 SECONDS;**

**"PRESS AND HOLD": PRESS THE BUTTON AND HOLD FOR AT LEAST 2 SECONDS.**

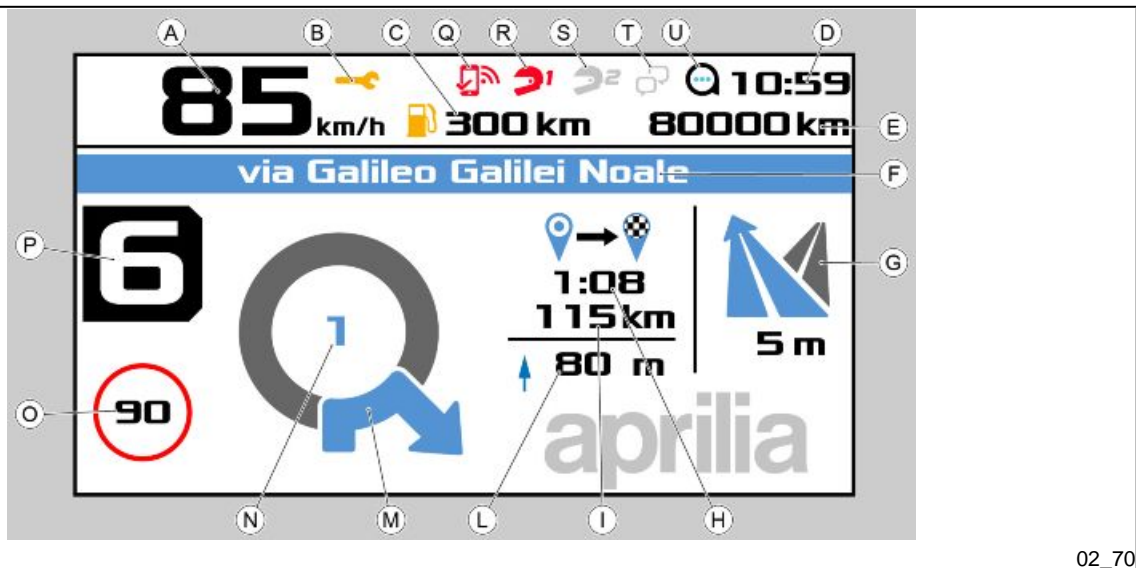

02\_70

### Navigation screen key

**A** = speed (speedometer) (viewable in km/h or in mph);

**B** = service icon;

**C** = remaining km/mi of the journey;

**D** = clock (displayed in 24 or 12 hours mode without AM / PM indication);

**E** = odometer;

**F** = destination address;

**G** = indication of next turn and distance to it;

**H** = time remaining to arrival at destination;

**I** = distance remaining to arrival at destination;

**L** = distance relative to indication "**M**";

**M** = direction of next turn;

**N** = exit number to follow on a roundabout;

**O** = indication of the road speed limit;

**P** = gear engaged;

**Q** = Audio link with smartphone used to make calls, use voice commands and play music;

**R** = rider headset connected/disconnected;

**S** = passenger headset connected/disconnected;

**T** = intercom active/deactivated;

**U** = data transmission with smartphone present/not present.

## **Ignition switch (02\_71)**

The ignition switch is on the front of the fuel tank where the steering headstock is.

The vehicle is supplied with two keys (one is the spare key).

The lights can only be switched off with the ignition switch turned to OFF.

### **NOTE**

**THE KEY ACTIVATES THE IGNITION SWITCH/ STEERING LOCK, THE FUEL TANK CAP LOCK AND THE SADDLE LOCK.**

**NOTE**

**THE LIGHTS COME ON AUTOMATICALLY AFTER THE ENGINE STARTS.**

**NOTE**

**KEEP THE SPARE KEY IN DIFFERENT PLACE, NOT WITH THE VEHICLE.**

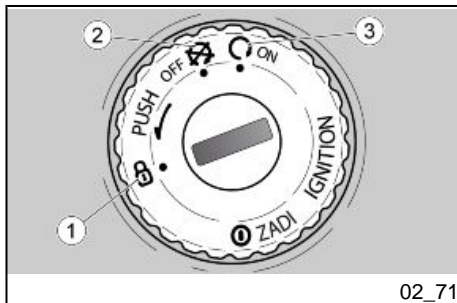

02\_71

**LOCK (1):** The steering is locked. It is not possible to start the engine or switch on the lights. The key can be extracted

**OFF (2):** The engine and lights cannot be set to work. The key can be extracted.

**ON (3):** The engine can be started. The key cannot be extracted.

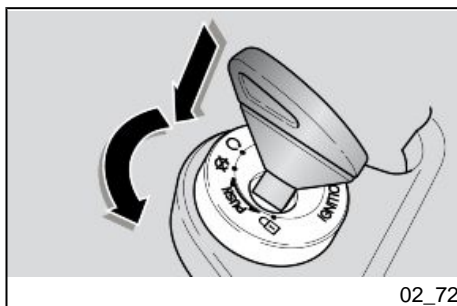

02\_72

### Locking the steering wheel (02\_72)

#### To lock the steering:

- Turn the handlebar completely to the left.
- Turn the ignition switch to **OFF**.
- Push in the key and turn it anticlockwise (to the left), steer the handlebar slowly until the key is set to «**LOCK**».
- Remove the key.

**CAUTION**

**TO AVOID LOSING CONTROL OF THE VEHICLE, NEVER TURN THE KEY TO "LOCK" WHILE RIDING.**

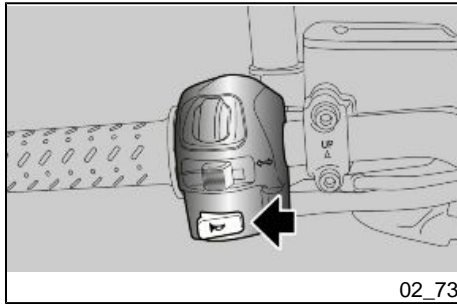
**Horn button (02\_73)**

Press it to activate the horn.

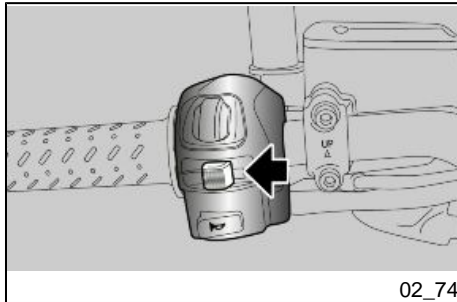
**Switch direction indicators (02\_74)**

Move the switch to the left, to indicate a left turn; move the switch to the right to indicate a right turn. Pressing the switch deactivates the turn indicator.

**CAUTION**

**IF THE WARNING LIGHT AND THE ARROWS FLASHES QUICKLY, IT MEANS THAT ONE OR BOTH TURN SIGNAL LIGHT BULBS ARE BURNT OUT.**



The turn indicators have a self-cancelling function that implements the following logic.

With the vehicle at a standstill (speed = zero), the turn indicators continue flashing indefinitely.

With the vehicle in motion, the turn signals self-cancel when one of the two following conditions is met:

- After a time (t) = 40 sec.
- After riding 500 m (0.31 mi)

If the vehicle speed reaches zero during this period, the time and distance counts are reset and start again from zero when the vehicle starts moving once again.

Switching on the opposite side turn indicators without pressing the switch in the intermediate reset position causes both the time and distance counters to reset and recommence from zero.

### High/low beam selector (02\_75)

Pushing the light switch to the right operates the high beam light;

To reactivate the low beam light, put the switch back in the central position.

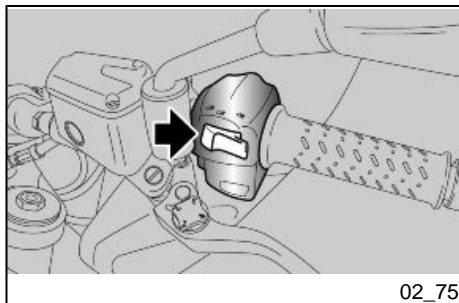

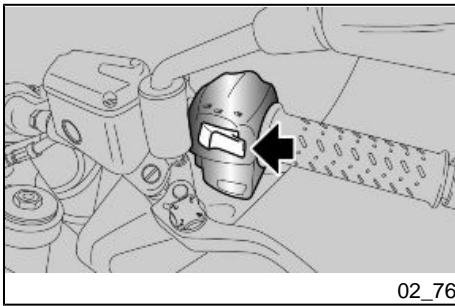

### Passing button (02\_76)

Uses the high beam flash in case of danger or emergency.

Releasing the switch deactivates the high beam flash.

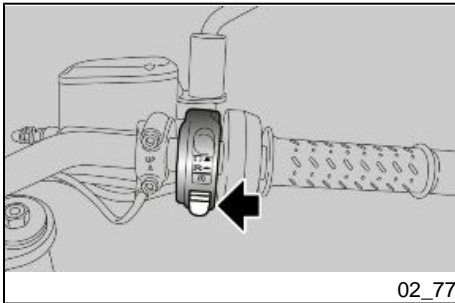

### Start-up button (02\_77)

With the key in the ignition and turned to ON, when the button is pressed, the starter motor will start the engine



**AFTER A FEW SECONDS FROM THE ENGINE START-UP, THE START-UP BUTTON ASSUMES THE MAPPING CHANGE FUNCTION.**

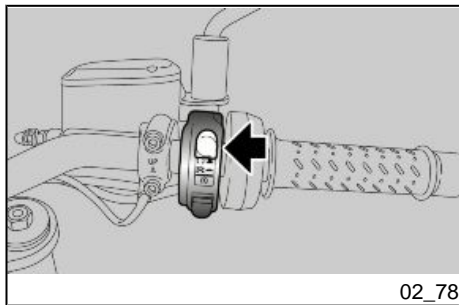

### Engine stop switch (02\_78)

It acts as a safety or emergency switch.

Press this switch to stop the engine.

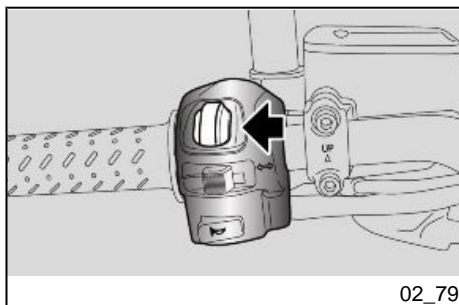

### Selector MODE (02\_79)

It allows you navigate through the functions of the instrument panel.

### System ABS

The ABS system is a device that prevents wheel locking in case of an emergency braking, thus increasing vehicle stability when braking, compared with a conventional braking system.

The ABS system improves vehicle control provided that the physical limits of vehicle grip on the road are not exceeded. The rider is fully responsible for riding at a suitable

speed based on weather and road conditions, always leaving an appropriate safety margin.

Under no circumstances can the ABS system compensate for the rider's misjudgment or improper use of brakes.

#### **NOTE**

**WHEN THE ABS STARTS WORKING, A PULSING IS FELT ON THE BRAKE LEVER.**



**THE ANTI-LOCK BRAKING SYSTEM OF THE WHEEL DOES NOT PREVENT FALLS WHILE CORNERING.**

**AN EMERGENCY BRAKING WITH THE VEHICLE INCLINED, HANDLEBAR TURNED, ON UNEVEN OR SLIPPERY ROADS, OR WITH POOR GRIP, CREATES A LACK OF STABILITY DIFFICULT TO HANDLE. RIDE CAREFULLY AND SENSIBLY AND ALWAYS BRAKE GRADUALLY.**

**DO NOT SPEED RECKLESSLY. THE VEHICLE GRIP ON THE ROAD IS SUBJECT TO LAWS OF PHYSICS WHICH NOT EVEN THE ABS SYSTEM CAN ELIMINATE.**

When the vehicle is started, after the initial instrument panel check cycle, the ABS warning lamp flashes until the vehicle reaches a speed of 3.1 mph (5 km/h), after which it goes out.

The ABS system can be deactivated by going into the menu, in the relevant section. In this case, the ABS warning light stays on permanently.

#### **CAUTION**

**IT IS DISABLED ONLY TEMPORARILY, WHEN THE KEY IS INSERTED THE SYSTEM IS ALWAYS ACTIVE.**

If, with the ABS system activated, the ABS warning lamp lights steadily or continues to flash even after exceeding a speed of 5 km/h (3.1 mph), this means that a fault has been detected and that the ABS system has been disabled.

In this case carry out the following operations:

- stop the vehicle;
- Key OFF-ON;
- ride the vehicle to a speed above 5 km/h (3.1 mph): the ABS warning light must be turned off;
- the ABS system is working.

If the ABS disabled indication remains:

#### **NOTE**

**SHOULD THIS OCCUR, CONTACT AN Aprilia Approved Dealer.**



**THE ABS SYSTEM ACTS ON BOTH THE FRONT AND REAR WHEELS BY OBTAINING INFORMATION FROM THE ROTATION/ LOCKING TONE WHEELS. ALWAYS CHECK THAT THE TONE WHEEL IS CLEAN, AND REGULARLY CHECK THAT THE DISTANCE FROM THE SENSOR IS CONSTANT ON ALL 360 DEGREES. SHOULD THE WHEELS BE REMOVED AND REFITTED, IT IS VERY IMPORTANT TO CHECK THAT THE DISTANCE BETWEEN TONE WHEEL AND SENSOR IS THE ONE SPECIFIED. FOR CHECKING AND ADJUSTMENT, CONTACT AN Authorised Aprilia Workshop.**



**WHERE THE MOTORCYCLE HAS AN ABS SYSTEM, NON-APPROVED BRAKE PADS AND TYRES COMPROMISE SMOOTH BRAKING, DRASTICALLY REDUCING DRIVING SAFETY.**

**NOTE**

THE SYSTEM'S SENSORS, HAVING A SIGNIFICANT ACCURACY OF READING THE TONE WHEELS, MAY GENERATE, A MOTORCYCLE STOPPED AND THE ENGINE RUNNING, INDICATION OF SPEED OF SOME km / h (mph) ON THE DIGITAL DISPLAY.

SUCH BEHAVIOUR IS TO BE CONSIDERED NORMAL AND DOES NOT CREATE MALFUNCTIONS IN THE SYSTEM.



IF THE GAP FOR ONE OR BOTH SENSORS IS NOT WITHIN THE TOLERANCE INDICATED BELOW, TAKE THE MOTORCYCLE TO AN Approved Aprilia Dealer

**Characteristic****Distance between tone wheel and front sensor**

0.1 - 3.17 mm (0.004 - 0.125 in)

**Distance between tone wheel and rear sensor**

0.1 - 2,00 mm (0.004 - 0.079 in)

**NOTE**

IN THE EVENT OF A PROLONGED ROTATION OF THE REAR WHEEL WITH THE FRONT WHEEL LOCKED (BURNOUT, MOTORCYCLE PLACED ON MIDDLE STAND, ETC.) THE SYSTEM CAN BE AUTOMATICALLY DEACTIVATED WHEN THE ABS and ATC INDICATOR LIGHT IS ON AND STEADY.

TO RESET THE SYSTEM SWITCH THE PANEL OFF AND THEN ON AGAIN.

**NOTE**

**THE VEHICLE IS WORKING PERFECTLY EVEN WITH ABS DISABLED BUT IT IS NOT RECOMMENDED TO DISABLE IT UNLESS ABSOLUTELY NECESSARY.**

**WITH ABS NOT ENABLED PAY THE UTMOST CAUTION WHILE DRIVING.**

**NOTE**

**THE SAFETY PROVIDED BY THE ABS DOES NOT, IN ANY CASE, JUSTIFY RISKY MANOEUVRES. EVEN THOUGH THE ABS SYSTEM ENSURES GREATER VEHICLE CONTROL IN THE EVENT OF EMERGENCY BRAKING, ALWAYS OBSERVE THE CORRECT MINIMUM SAFETY DISTANCE FROM THE VEHICLE IN FRONT OF YOU.**

**System ATC (Aprilia Traction Control) (02\_80)**

ATC is a system that monitors and, if necessary, limits rear wheelspin under acceleration to increase vehicle stability.

While ATC improves vehicle control, it does not allow the physical handling limits of the vehicle to be exceeded. The rider is fully responsible for riding at a suitable speed based on weather and road conditions, always leaving an appropriate safety margin.

Under no circumstances can ATC compensate for any rider error or improper use of the throttle.



**THE TRACTION CONTROL SYSTEM CANNOT PREVENT FALLS WHILE CORNERING.**

**ACCELERATING SUDDENLY WHILE THE VEHICLE IS INCLINED OR WITH THE HANDLEBARS TURNED WILL PUT THE VEHICLE IN AN UNSTABLE STATE THAT IS EXTREMELY DIFFICULT TO RECTIFY.**

**DO NOT SPEED RECKLESSLY. LIMITS OF GRIP ARE DETERMINED BY LAWS OF PHYSICS WHICH EVEN THE ATC SYSTEM CANNOT OVERCOME.**

Using the "MODE selector", the ATC level may be changed from value "1" (minimum intervention) to value "3" (maximum intervention).

To perform this change, refer to paragraph "ADVANCED FUNCTIONS".

#### **TABLE OF RECOMMENDED SETTINGS**

<b>Engine map</b>	<b>ATC</b>	<b>Road surface / Driving style</b>
Touring	2	Touring
Sport	1	Sporting
Rain	3	Wet road surface / Low grip

#### **NOTE**

**THE TABLE IS ONLY INTENDED AS A GUIDELINE FOR SETTING UP THE ATC SYSTEM LEVELS. EACH RIDER MAY PERSONALISE THE LEVEL TO THEIR OWN PREFERENCE IN ACCORDANCE WITH ABILITY, RIDING STYLE AND ROAD CONDITIONS.**



## WARNING AND INDICATOR LIGHTS KEY

- **Indicator light off:** with the system active after exceeding 5 km/h (3.1 mph) then when the panel is switched on;

- **Indicator light continuously lit:** with the system deactivated or intentionally or when there is a malfunction;

- **Indicator light flashing slowly:**

(with the vehicle at a standstill) with the ATC system active after the panel has been switched on, before exceeding 5 km/h (3.1 mph);

(with the vehicle moving) with the ATC system active, in the event of certain types of malfunctions; If the malfunction persists for more than 180 seconds, the indicator light remains on and fixed.

- **Indicator light flashing quickly: when the system intervenes effectively on the traction control.**

## ATC SYSTEM DEACTIVATED MANUALLY

At key-on and after the initial dashboard check cycle, if the system is deactivated, the ATC indicator light remains lit and fixed until the rider activates the system again.

## ATC SYSTEM ACTIVE

At key-on and after the initial dashboard check cycle, if the system was active at the last key-off, the ATC indicator light flashes until the vehicle exceeds 5 Km/h (3.1 mph), after which it goes out.



If the ATC indicator light remains on and the message "ALLARM ATC DISABLED" is displayed on the dashboard, it means that a malfunction was detected and that the ATC was automatically deactivated.

In this case carry out the following operations:

- stop the vehicle;
- Key OFF-ON;
- (IF APPLICABLE) start the engine;
- reactivate the system manually;
- ride the vehicle to a speed above 5 km/h (3.1 mph): the ATC warning light should switch off;
- ATC system working correctly.

If the 'ATC system deactivated' indication persists:

#### NOTE

**SHOULD THIS OCCUR, CONTACT AN Aprilia Approved Dealer.**



**THE ATC SYSTEM ACTS ON BOTH THE REAR WHEEL OBTAINING INFORMATION FROM THE ROTATION/ LOCKING TONE WHEELS MOUNTED ON BOTH WHEELS. ALWAYS CHECK THAT THE TONE WHEELS ARE CLEAN, AND REGULARLY CHECK THAT THE GAP BETWEEN THE TONE WHEEL AND THE SENSOR IS CONSTANT AROUND THE ENTIRE CIRCUMFERENCE OF THE TONE WHEEL ITSELF. SHOULD THE WHEELS BE REMOVED AND REFITTED, IT IS VERY IMPORTANT TO CHECK THAT THE DISTANCE BETWEEN TONE WHEEL AND SENSOR IS THE ONE SPECIFIED. FOR CHECKING AND ADJUSTMENT, CONTACT AN Authorised Aprilia Workshop.**

**NOTE**

IN THE EVENT OF A PROLONGED ROTATION OF THE REAR WHEEL WITH THE FRONT WHEEL LOCKED (BURNOUT, MOTORCYCLE PLACED ON MIDDLE STAND, ETC.) THE SYSTEM CAN BE AUTOMATICALLY DEACTIVATED WHEN THE ABS and ATC INDICATOR LIGHT IS ON AND STEADY.

TO RESET THE SYSTEM SWITCH THE PANEL OFF AND THEN ON AGAIN.

**NOTE**

THE SYSTEM'S SENSORS, HAVING A SIGNIFICANT ACCURACY OF READING THE TONE WHEELS, MAY GENERATE, A MOTORCYCLE STOPPED AND THE ENGINE RUNNING, INDICATION OF SPEED OF SOME km / h (mph) ON THE DIGITAL DISPLAY.

SUCH BEHAVIOUR IS TO BE CONSIDERED NORMAL AND DOES NOT CREATE MALFUNCTIONS IN THE SYSTEM.

**Characteristic**

**Distance between tone wheel and front sensor**

0.1 - 3.17 mm (0.004 - 0.125 in)

**Distance between tone wheel and rear sensor**

0.1 - 2,00 mm (0.004 - 0.079 in)

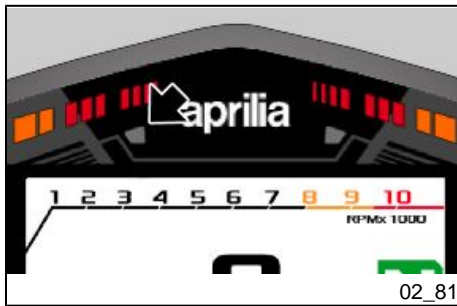

02\_81

## Immobilizer system operation (02\_81, 02\_82, 02\_83)

For enhanced theft protection, the vehicle is equipped with an electronic immobilizer system that is activated automatically when the ignition key is removed.

Keep the second key in a safe place since it is not possible to make a copy if it gets lost.

This would imply replacing numerous parts of the vehicle (besides the locks).

Each key in the grip has an electronic device - transponder - which modulates the radio frequency signal emitted by a special aerial inside the switch when the vehicle is started.

The modulated signal is the "password" by which the appropriate central unit recognises the key and only after this occurs, it allows the engine start-up.

### CAUTION

**THE IMMOBILIZER SYSTEM CAN MEMORISE UP TO FOUR KEYS.**

**DATA STORAGE OPERATION CAN ONLY BE PERFORMED AT AN Authorised Aprilia DEALER.**

**DATA STORAGE PROCEDURE CANCELS THE EXISTING CODES. THEREFORE, IF A CUSTOMER WANTS TO PROGRAM SOME NEW KEYS, S/HE SHOULD GO TO THE DEALER TAKING ALL THE KEYS S/HE WANTS TO ENABLE.**

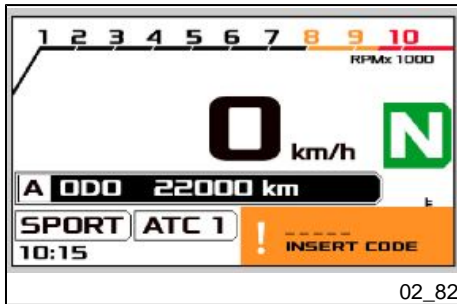

02\_82

In the event the instrument panel detects a fault with the immobilizer system when the key is connected, you will need to enter the user code to start the motorcycle. At the same time the indicator light appears on the instrument panel, the general red warning light will come on.

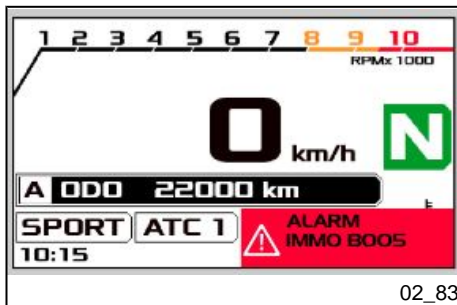

Once the code has been correctly entered, the error will be displayed on the screen. It is then possible to start the motorcycle so you can go immediately to an Authorised **Aprilia** Dealership.

#### CAUTION

**PRESSING OR MOVING ANY CONTROL ON THE LEFT SWITCH CLUSTER, IT IS POSSIBLE TO REMOVE THE ERROR NOTIFICATION SCREEN, BUT THE SCREEN WILL BE VISIBLE AGAIN AFTER ABOUT 10 SECONDS.**

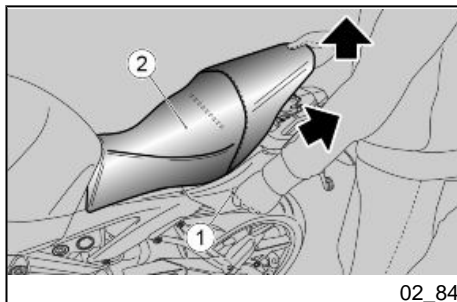

#### Opening the saddle (02\_84, 02\_85)

- Rest the vehicle on its stand.
- Insert the key (1) in the lock.
- Turn the key (1) anticlockwise, pull out and lift the saddle (2).

There is a handy document compartment in the vehicle tail fairing. Remove the saddle (2) to reach it.

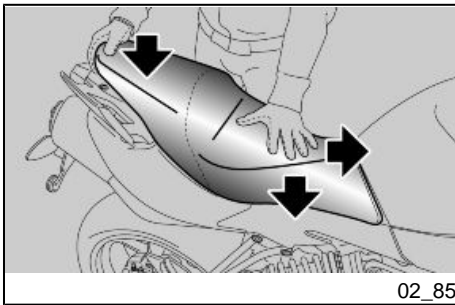

02\_85

### To lock the saddle (2):

- Move the saddle (2) so that the front retainers fasten correctly.
- Press on the middle of the saddle (2), at the rear fasteners, to insert them correctly.
- Press down and push the saddle (2) forwards, engaging the lock.

### CAUTION

**BEFORE LOWERING AND LOCKING THE SADDLE, CHECK THAT THE IGNITION KEY HAS NOT BEEN LEFT THE KEY IN THE DOCUMENT COMPARTMENT.**



**BEFORE SETTING OFF, MAKE SURE THAT THE SADDLE IS CORRECTLY LOCKED INTO POSITION.**

### Glove

- To access the glove compartment, the rider seat must be removed.

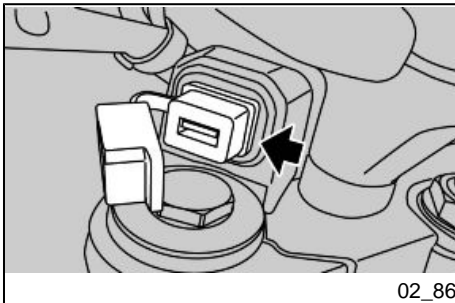

02\_86

### USB Port (02\_86)

A USB port is present on the left side of the motorcycle, on the upper steering plate

To use it, remove the protection cap.



**TO AVOID THAT WATER AND/OR HUMIDITY CAN DAMAGE THE USB PLUG, DO NOT CONNECT ANY DEVICES IN CASE OF RAIN.**



**IF A USB DEVICE IS CONNECTED, ENSURE THE CORRECT POSITIONING OF THE CABLE TO AVOID THAT IT WILL BE SMASHED.**

The USB port is active once the key is turned to «ON».

#### **WARNING**

**PROLONGED USE OF THE PLUG SOCKET MAY RESULT IN PARTIAL DISCHARGE OF THE BATTERY.**

#### **USB PORT**

Output voltage	(5.00+/-0.25) DC
Charging current	1A Max

#### **Identification (02\_87, 02\_88)**

Write down the chassis and engine number in the specific space in this booklet. The chassis number is handy when purchasing spare parts.

#### **CAUTION**



**THE MODIFICATION OF THE IDENTIFICATION CODES IS A SERIOUS PUNISHABLE CRIME. HOWEVER, THE LIMITED WARRANTY FOR NEW VEHICLES WILL**

**BE VOID IF THE VEHICLE IDENTIFICATION NUMBER (VIN) HAS BEEN MODIFIED OR NOT PROMPTLY DETERMINED.**

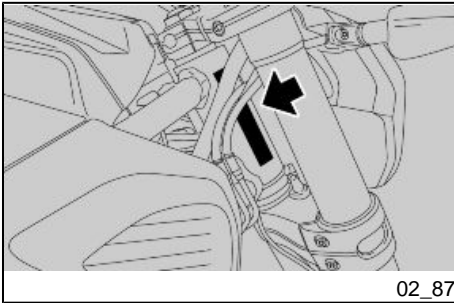

**FRAME NUMBER**

The chassis number is stamped on the RH side of the headstock.

Chassis No. ....

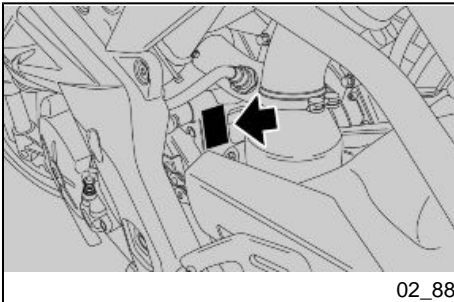

**ENGINE NUMBER**

The engine number is printed on the base of the engine crankcase, left hand side.

Engine No. ....



# SHIVER 900



**Chap. 03**  
**Use**

## Checks (03\_01)

### CAUTION



**BEFORE SETTING-OFF, ALWAYS CARRY OUT A PRELIMINARY CHECK OF THE VEHICLE, SO THAT IT OPERATES CORRECTLY AND SAFELY. FAILURE TO DO SO MAY LEAD TO SERIOUS PERSONAL INJURIES OR VEHICLE DAMAGE. CONTACT AN Authorised Aprilia Dealer IMMEDIATELY IF IN ANY DOUBT ABOUT THE FUNCTIONS OF ANY CONTROLS OR IF ANY MALFUNCTIONS ARE FOUND OR SUSPECTED. IT DOES NOT TAKE MUCH TIME TO DO A CHECK AND THE SAFETY BENEFITS ARE CONSIDERABLE.**



This vehicle has been programmed to indicate in real time any operation failure stored in the electronic control unit memory.

Every time the ignition switch is turned to "ON", the alarm LED warning lights turn on for about three seconds on the dashboard.

### PRE-RIDE CHECKS

Front and rear disc brake

Check for proper operation. Check brake lever empty travel and brake fluid level. Check for leaks. Check

	brake pads for wear. If necessary top-up with brake fluid.
Throttle grip	Check that the rotation is smooth in both directions and that there is no jamming.
Engine oil	Check and/or top-up as required.
Wheels/ tyres	<p>Check that tyres are in good conditions. Check inflation pressure, tyre wear and potential damage.</p> <p>Remove any possible strange body that might be stuck in the tread design.</p>
Brake levers	<p>Check they function smoothly.</p> <p>Lubricate the joints and adjust the travel if necessary.</p>
Clutch lever	<p>Check it operates smoothly.</p> <p>Lubricate the joint and adjust the travel if necessary.</p>
Steering	Makes sure that the steering turns freely, is even, smooth and with zero play or slackening to the limit stop on both sides.
Side stand	Check that it slides smoothly and that it snaps back to its rest position upon spring tension. Lubricate couplings and joints if necessary.

Check that the side stand safety switch functions correctly.

Clamping elements

Check that the clamping elements are not loose.

Adjust or tighten them as required.

Fuel tank

Check level and refill if necessary.

Check the circuit for leaks or obstructions.

Check that the tank cap closes correctly.

Engine stop switch (ON - OFF)

Check function.

Lights, indicator lights, horn, rear stop light switch and electrical devices

Check function of horn and lights. Replace bulbs or repair any faults noted.

Tone wheels

Check that the tone wheels are perfectly clean and in good conditions.

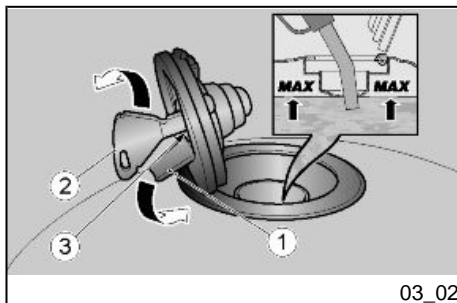

03\_02

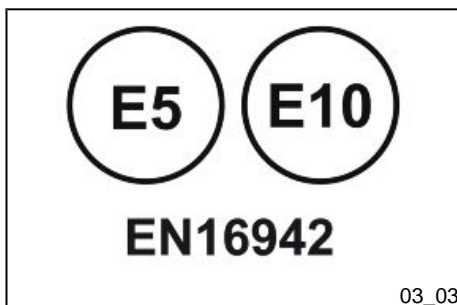

03\_03

## Refuelling (03\_02, 03\_03)

To refuel:

- Lift the cover (1).
- Insert the key (2) into the fuel tank cap lock (3).
- Turn the key clockwise, pull and open the fuel filler cap.

### CAUTION



**ALWAYS USE PETROL WITH A MAXIMUM OF 10% BIOETHANOL CONTENT (E10).**

**DO NOT USE PETROL WITH AN ETHANOL CONTENT HIGHER THAN 10%; THIS USE COULD DAMAGE THE FUEL SYSTEM COMPONENTS AND/OR COMPROMISE ENGINE PERFORMANCE.**

### Characteristic

#### Fuel (reserve included)

14.5 l (3.19 UK gal; 3.83 US gal)

#### Fuel reserve

3 l (0.66 UK gal; 0.79 US gal)

- Refill.

### CAUTION



**DO NOT ADD ADDITIVES OR ANY OTHER SUBSTANCES TO THE FUEL.  
WHEN USING A FUNNEL, ENSURE THAT IT IS PERFECTLY CLEAN.**



**DURING REFUELLING AVOID FUEL LEAKAGES, WHICH MAY CAUSE DAMAGE TO THINGS OR PERSONS AND FIRE HAZARD.**

**DURING REFUELLING, AVOID THE USE OF ELECTRIC DEVICES AND/OR MOBILE PHONES, BECAUSE FUEL VAPOURS MAY CAUSE DAMAGE TO OBJECTS AND/OR PERSONAL INJURIES.**

**After refuelling:**

- The cap can only be closed if the key (2) is inserted.
- Once the key (2) is inserted, press the cap to close it again.
- Remove the key (2).
- Close the cover (1).



**MAKE SURE THE CAP IS TIGHTLY CLOSED.**

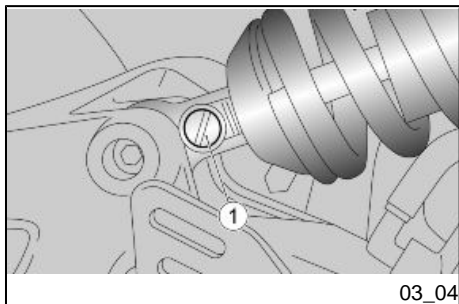

**Rear shock absorbers adjustment (03\_04, 03\_05, 03\_06)**

The rear suspension consists of a spring-shock absorber unit connected to the frame by uniball joints.

To adjust the setting, the shock absorber has an adjuster screw (1) for adjusting the rebound hydraulic braking, a ring nut for adjusting the spring preload (2) and a locking ring nut (3).

03\_04

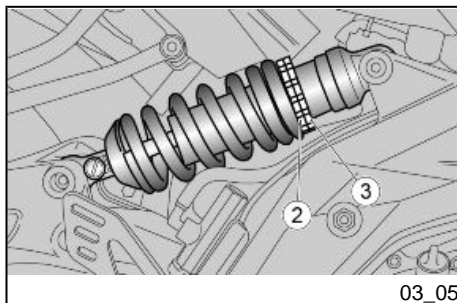
**CAUTION**

**CARRY OUT MAINTENANCE OPERATIONS AT HALF THE INTERVALS RECOMMENDED IF THE VEHICLE IS USED IN WET OR DUSTY AREAS, OFF ROAD OR FOR SPORTING APPLICATIONS.**

**CHECK AND IF NECESSARY, ADJUST THE REAR SHOCK ABSORBER.**

**THE STANDARD REGULATION OF THE REAR SHOCK ABSORBER IS INTENDED TO SATISFY NORMAL TOUR DRIVING CONDITIONS.**

**IN ANY CASE IT IS POSSIBLE TO INSERT PERSONAL SETTINGS, DEPENDING ON VEHICLE UTILIZATION.**



**TO COUNT THE NUMBER OF CLICKS OF THE ADJUSTER (1) ALWAYS START FROM THE MOST RIGID SETTING (COMPLETE CLOCKWISE ROTATION).**

**TO PREVENT DAMAGE TO THE ADJUSTER SCREWS (1), NEVER FORCE THEM BEYOND THE END OF TRAVEL IN EITHER DIRECTION.**

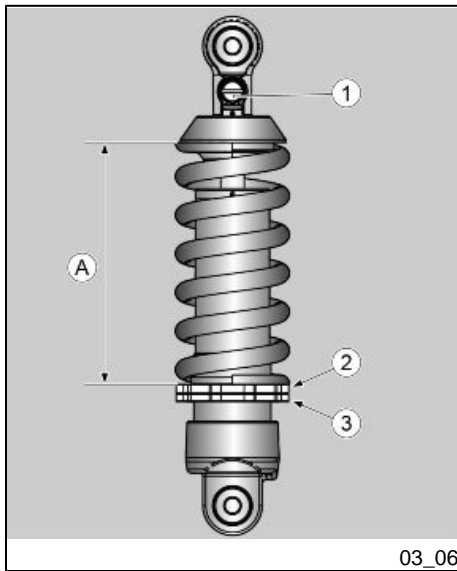

- Using the specific spanner, unscrew the locking ring nut (3).
- Use the adjuster ring nut (2) to adjust the preload of the spring (A).
- Once the adjustment is done, screw the ring nut (3).
- Use the screw (1) to adjust the shock absorber rebound hydraulic braking.



**SET SPRING PRELOADING AND SHOCK ABSORBER REBOUND DAMPING ACCORDING TO THE VEHICLE USE CONDITIONS.**

**IF THE SPRING PRELOADING IS INCREASED, IT IS NECESSARY TO INCREASE THE REBOUND DAMPING ACCORDINGLY TO AVOID SUDDEN JERKS WHEN RIDING.**

**IF NECESSARY, CONTACT AN OFFICIAL APRILIA DEALER. TRY RIDING THE VEHICLE ON THE STREET UNTIL THE OPTIMUM ADJUSTMENT IS OBTAINED.**

### Rear shock absorbers setting

#### **REAR SHOCK ABSORBER - ADJUSTMENT**

Description	Pilot	Pilot + Passenger + Baggage
Spring length (preloaded)	168 mm (6.61 in)	160 mm (6.30 in)
Rebound adjustment	12	6 / 7

(\* ) = clockwise



(\*\*) = anticlockwise

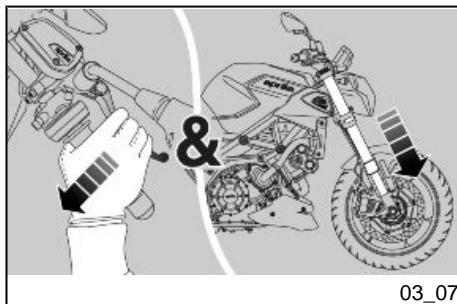

## Front fork adjustment (03\_07)

- Operating the front brake lever, press the handlebar repeatedly to send the fork fully down. The shock absorber should compress and extend smoothly with no signs of oil leakage on the stanchions.
- Check the tightening of all the elements and the correct operation of the front and rear suspension joints.

### CAUTION

**PLEASE CONTACT AN Authorised Aprilia Dealer TO HAVE THE FRONT FORK OIL CHANGED AND ITS OIL SEALS REPLACED.**

The front suspension consists of a hydraulic fork connected to the headstock by means of two plates.

The right stem of the fork has an upper nut (2) for adjusting the spring pre-load and an upper adjustment screw (1) for adjusting the hydraulic braking in rebound.



**DO NOT FORCE THE ROTATION OF THE ADJUSTMENT SCREW BEYOND THE LIMIT STOP IN BOTH DIRECTIONS, IN ORDER TO PREVENT ANY DAMAGE.**

**WHEN SPRING PRE-LOAD IS INCREASED, REBOUND DAMPING MUST ALSO BE INCREASED TO PREVENT EXCESSIVE SUSPENSION KICKBACK WHEN RIDING.**

The standard front fork setting is adjusted to suit most high and low speed riding conditions, whether the vehicle is partially or fully loaded.

However, the setting can be modified for specific needs according to vehicle use.

#### CAUTION

**FOR THE CORRECT SETTING PARAMETERS, READ THE PARAGRAPH "SETTING THE FRONT FORK" CAREFULLY.**

**TAKE YOUR VEHICLE TO AN Authorised Aprilia Dealer, IF NECESSARY.**

#### Front fork setting (03\_08, 03\_09)



**TO COUNT THE NUMBER OF CLICKS AND/OR REVOLUTIONS OF ADJUSTMENT SETTINGS ALWAYS START FROM THE MOST RIGID SETTING (WHOLE CLOCKWISE ROTATION OF THE SETTING).**

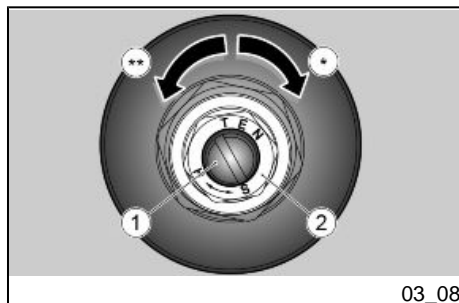

03\_08

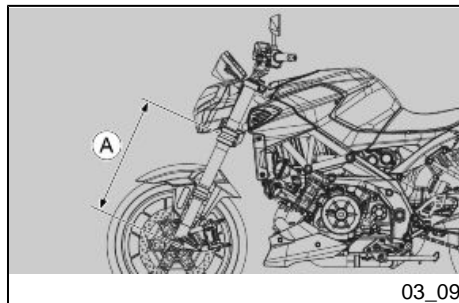

03\_09

## FRONT FORK - ADJUSTING

Description	Pilot	Pilot + Passenger + Baggage
Rebound damping adjustment, screw (1)	from completely closed (*) unscrew (**) 6 / 7 clicks	from completely closed (*) unscrew (**) 6 / 7 clicks
Spring preload (2)	2 notches (4 total)	2 notches (4 total)
Extracting fork (A) (***) (from under lower plate to wheel centre)	480 mm (18.90 in)	480 mm (18.90 in)

(\*) - Clockwise

(\*\*) - Anticlockwise

(\*\*\*) - this type of adjustment may only be made by an **Authorised Aprilia Dealer**.

### Justering af greb til forbremse (03\_10)

It is possible to adjust the distance between the end of the lever (1) and the grip (2), turning the adjuster (3).

- Push the control lever (1) forwards and turn the adjuster (3) until the lever (1) is at the desired distance.
- Turning the adjuster anticlockwise, the lever (1) gets closer to the grip (2).

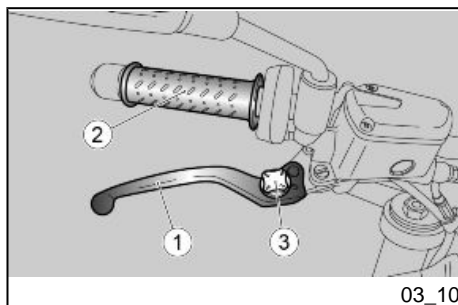

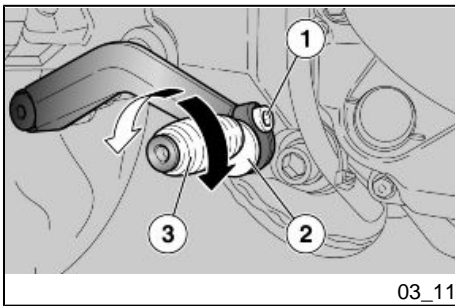

### Rear brake pedal adjustment (03\_11)

The control levers are positioned ergonomically when the vehicle is being assembled. if necessary, it is possible to customise the position of the levers.

- Rest the vehicle on its stand.
- Partially undo the screw (1).
- Turn the cam (2) finding the best position for the pedal (3).
- Tighten the screw (1) and check the cam is stable in position.

#### CAUTION

**TO ADJUST THE BRAKE LEVER CLEARANCE, CONTACT AN Official Aprilia Dealer.**

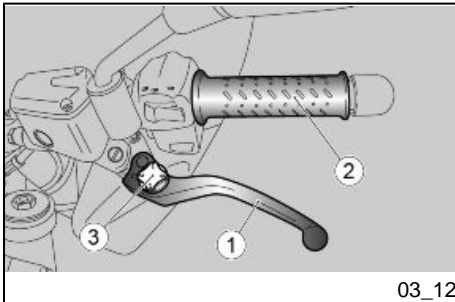

### Clutch lever adjustment (03\_12)

It is possible to adjust the distance between the end of the lever (1) and the grip (2), turning the adjuster (3).

- Push the control lever (1) forwards and turn the adjuster (3) until the lever (1) is at the desired distance.
- Turning the adjuster anticlockwise, the lever (1) gets closer to the grip (2).

### Running in

Running the engine in correctly is essential for ensuring engine longevity and functionality. Twisty roads and gradients are ideal for running in the engine, brakes and suspension effectively. Vary your riding speed during the running in period. This en-

tures that components operate in "loaded" conditions and then "unloaded" conditions, allowing the engine components to cool.

#### **CAUTION**

**THE FULL PERFORMANCE OF THE VEHICLE IS ONLY AVAILABLE AFTER THE SERVICE AT THE END OF THE RUNNING IN PERIOD.**

#### **Follow these guidelines:**

- Do not fully open the throttle grip abruptly at low engine speeds, either during or after the running in period.
- During the first 100 Km (62.14 miles) use the brakes gently, avoiding sudden or prolonged braking. That is to permit the adequate adjustment of the pad friction material to the brake discs.
- During the first 250 km (155.34 mi) we recommend not exceeding 6500 rpm and not fully opening the throttle for prolonged periods. After this, up to about 1000 km (621.37 mi), gradually increase the rpm and the periods of "full throttle".

#### **CAUTION**

**AFTER THE SPECIFIED MILEAGE, TAKE YOUR VEHICLE TO AN Authorised Aprilia Dealer FOR THE CHECKS INDICATED IN THE "SCHEDULED MAINTENANCE TABLE" IN THE SCHEDULED MAINTENANCE SECTION, TO AVOID INJURING YOURSELF, OTHERS AND /OR DAMAGING THE VEHICLE.**

### **Starting up the engine (03\_13, 03\_14, 03\_15)**

**This vehicle is extremely powerful and must be used carefully and driven with caution and respect for its power and potential.**

**Do not put objects between the handlebar and the instrument panel, so as not to impede the rotation of the handlebar and obstruct the view of the instrument panel.**



**EXHAUST FUMES CONTAIN CARBON MONOXIDE, AN EXTREMELY HARMFUL SUBSTANCE IF INHALED.**

**NEVER START THE ENGINE IN A CLOSED OR INSUFFICIENTLY VENTILATED SPACE.**



**FAILURE TO OBSERVE THIS WARNING COULD LEAD TO UNCONSCIOUSNESS AND EVEN DEATH DUE TO SUFFOCATION.**

#### **CAUTION**

**WITH THE SIDE STAND LOWERED, THE ENGINE MAY ONLY BE STARTED WITH THE GEARBOX IN NEUTRAL. IF YOU ATTEMPT TO ENGAGE THE GEAR, THE ENGINE WILL STOP.**

**WITH THE SIDE STAND RETRACTED, THE ENGINE MAY BE STARTED WITH THE GEARBOX IN NEUTRAL OR WITH THE GEAR ENGAGED AND THE CLUTCH LEVER OPERATED.**

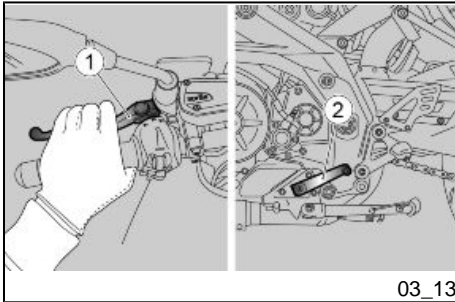

- Get on the motorcycle, assuming the correct driving posture.
- Make sure that the side stand has been fully retracted.
- Operate the front or rear brake (or both).
- Operate the clutch lever (1) and make sure that the transmission (2) is in neutral.

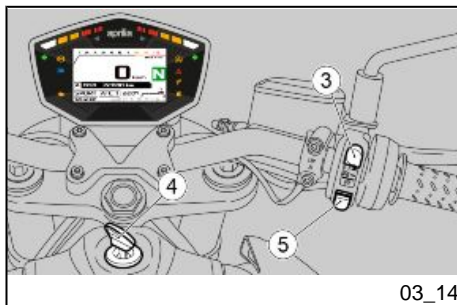

03\_14

- Set the switch for stopping the engine (3) on "RUN" Turn the ignition key (4) to "ON".

At this stage:

- The starting screen will be displayed on the digital display for about 2 seconds and then the screen with the standard parameters will appear.
- All the indicator lights on the dashboard will come on for about 2 seconds.
- Press the starter button (5) once only.
- With the engine operating normally, the number of rpm at which the engine is operating will be displayed instantaneously.



**IF THE LOW FUEL WARNING LIGHT ON THE DASHBOARD TURNS ON, REFUEL THE VEHICLE AT ONCE.**

**INTENSE USE ON LOW FUEL CAN DAMAGE THE ENGINE.**



**ON NEW VEHICLES, THE SHIFT LIGHT THRESHOLD IS SET TO 6,500 RPM. RAISE THE THRESHOLD GRADUALLY UNTIL YOU HAVE BECOME FAMILIAR WITH THE VEHICLE AND THE RUN-IN HAS BEEN COMPLETED.**



**AFTER A FEW SECONDS FROM THE ENGINE START-UP, THE START-UP BUTTON ASSUMES THE MAPPING CHANGE FUNCTION.**



03\_15



IF THE GENERAL WARNING INDICATOR LIGHT ON THE DASHBOARD COMES ON, IT MEANS THAT THE CONTROL UNIT HAS ENCOUNTERED A FAULT, THEREFORE IT IS NECESSARY TO CONTACT AN Authorised Aprilia Dealer.



DO NOT SET OFF SUDDENLY WHEN THE ENGINE IS COLD. RIDE AT LOW SPEED FOR SEVERAL KILOMETRES. THIS WILL ALLOW THE ENGINE TO WARM UP AND REDUCE POLLUTING EMISSIONS AND FUEL CONSUMPTION.

### **Moving off / riding (03\_16, 03\_17, 03\_18, 03\_19)**

#### **CAUTION**

WHEN TRAVELLING WITHOUT PASSENGERS, MAKE SURE THE PASSENGER FOOTRESTS ARE FOLDED UP.

#### **CAUTION**

PASSENGERS MUST BE SUITABLY INSTRUCTED ON HOW TO BEHAVE TO PREVENT DANGEROUS SITUATIONS WHEN RIDING.

BEFORE SETTING OFF, MAKE SURE THE STAND HAS BEEN COMPLETELY RETRACTED TO ITS POSITION.



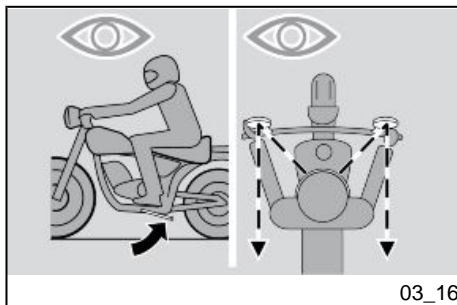

03\_16

**To start:**

- Turn on the engine.
- Adjust the inclination of the rear-view mirrors to ensure proper visibility.

**CAUTION**

**WITH THE VEHICLE AT STANDSTILL, PRACTICE USING THE REAR-VIEW MIRRORS. THE MIRRORS ARE CONVEX, SO OBJECTS MAY SEEM FARTHER AWAY THAN THEY REALLY ARE. THESE MIRRORS OFFER A WIDE-ANGLE VIEW AND ONLY EXPERIENCE HELPS YOU JUDGE THE DISTANCE SEPARATING YOU AND THE VEHICLE BEHIND.**

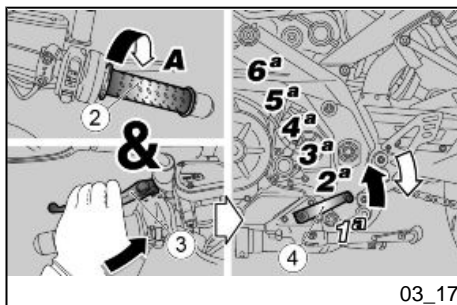

03\_17

- With the throttle (2) closed and the engine at minimum, operate the clutch lever (3).
- Push the gearbox lever (4) downward to select the first gear.
- Release the clutch lever (activated during start-up).

**CAUTION**

**WHEN TURNING OFF THE VEHICLE, DO NOT RELEASE THE CLUTCH TOO QUICKLY OR SUDDENLY, AS THIS COULD CAUSE THE ENGINE TO STOP OR THE VEHICLE TO REAR UP ON THE BACK WHEEL. DO NOT ACCELERATE SUDDENLY WHEN RELEASING THE CLUTCH FOR THE SAME REASON.**

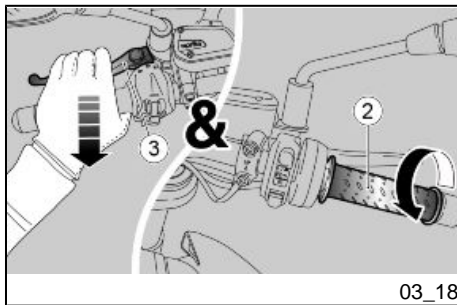

- Slowly release the clutch lever (3) and at the same time accelerate by turning the throttle (2).

The vehicle starts moving forward.

- For the first kilometres travelled, limit the speed in order to warm up the engine.

#### NOTE

**THE VEHICLE HAS AN RPM LIMITER THAT IS PART OF THE "RIDE-BY-WIRE" INJECTION SYSTEM.**

- Increase speed by gradually turning the throttle grip (2), without exceeding the recommended rpm.



**SELECT THE APPROPRIATE GEAR AND SPEED FOR THE CONDITIONS.  
DO NOT ALLOW THE ENGINE SPEED TO DROP EXCESSIVELY.**

- Release the throttle (2), operate the clutch lever (3), lift the gear lever (4), release the clutch (3) and accelerate.
- Repeat the last two operations and engage a higher gear.



**IF THE GENERAL WARNING LIGHT LIGHTS UP ON THE DASHBOARD, ACCOMPANIED BY THE MESSAGE "ALLARM OIL PRESSURE" ON THE DIGITAL DISPLAY, WHEN THE ENGINE IS RUNNING NORMALLY, IT MEANS THAT THE ENGINE OIL PRESSURE IS LOW.**

**IN THIS CASE STOP THE ENGINE AND CONTACT AN Official Aprilia Dealer.**

**IT IS RECOMMENDED YOU GO DOWN FROM A HIGHER GEAR TO A LOWER GEAR:**

- When riding downhill and under braking, using engine compression to increase braking power.
- When going uphill, when the engaged gear does not suit the speed (high gear, moderate speed) and the number of engine revs falls.

**CAUTION**

**DOWN-SHIFT ONE GEAR AT A TIME; WHEN SHIFTING TO A LOWER GEAR, DOWN-SHIFTING MORE THAN ONE GEAR AT A TIME COULD OVER-REV THE ENGINE; THAT IS, THE MAXIMUM RPM VALUE PERMITTED FOR THE ENGINE COULD BE EXCEEDED.**

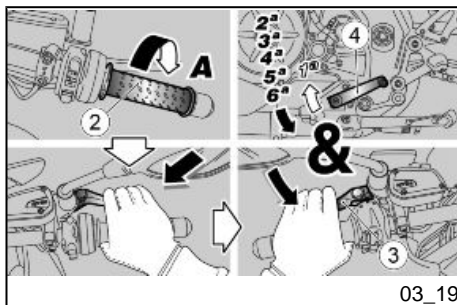

- Release the throttle (2).
- If necessary, pull the brake levers gently and reduce speed.
- Pull the clutch lever (3) and push the gear lever (4) down to select the lower gear.
- Release the brake levers when it is operated.
- Release the clutch lever (3) and accelerate moderately.

**CAUTION**

**STOP THE VEHICLE MAINLY USING THE FRONT BRAKE. THE REAR BRAKE MUST ONLY BE USED TO BALANCE THE BRAKING EFFECT, AND ONLY TOGETHER WITH THE FRONT BRAKE.**



**IF THE MULTI-FUNCTION DIGITAL DISPLAY SHOWS THE COOLANT TEMPERATURE IS HIGHER THAN 115°C (239°F) STOP THE VEHICLE AND LET THE ENGINE RUN AT 3000 rpm FOR ABOUT TWO MINUTES, ALLOWING THE COOL-**

**ANT TO CIRCULATE REGULARLY IN THE SYSTEM; THEN TURN THE ENGINE STOP SWITCH TO "OFF" AND CHECK THE COOLANT LEVEL.**

**IF, AFTER CONTROLLING THE COOLANT LEVEL, THE TEMPERATURE INDICATOR KEEPS FLASHING, CONTACT AN Authorised Aprilia Dealer.**

**DO NOT STOP THE ENGINE BY TURNING THE IGNITION KEY TO "KEY OFF", AS THIS WILL STOP THE COOLING FAN REGARDLESS OF THE COOLANT TEMPERATURE, CAUSING THE COOLANT TEMPERATURE TO RISE FURTHER.**

**IN MANY CASES THE ENGINE MAY CONTINUE TO PERFORM, BUT WITH REDUCED PERFORMANCE; CONTACT AN Authorised Aprilia Dealer IMMEDIATELY.**

**IN ORDER TO AVOID CLUTCH OVERHEATING, SHUT THE ENGINE OFF AS SOON AS POSSIBLE ONCE THE VEHICLE HAS STOPPED AND AT THE SAME TIME THE GEAR IS ENGAGED AND THE CLUTCH LEVER OPERATED.**



**USING JUST THE FRONT OR THE REAR BRAKE ONLY SIGNIFICANTLY REDUCES THE BRAKING FORCE OF THE VEHICLE.**

**WHEN STOPPING UPHILL, DECELERATE COMPLETELY AND ONLY USE THE BRAKES TO MAINTAIN THE VEHICLE IN THE STOPPED POSITION.**

**USING THE ENGINE TO KEEP THE MOTORCYCLE STOPPED COULD CAUSE THE CLUTCH TO OVERHEAT. BRAKING CONTINUOUSLY WHEN DRIVING DOWNHILL COULD CAUSE THE BRAKE PADS TO OVERHEAT, WHICH REDUCES BRAKING AND LIMITS BRAKING POWER.**

**IT IS RECOMMENDED TO USE THE ENGINE COMPRESSION, DOWNSHIFTING AND USING BOTH BRAKES INTERMITTENTLY.**

**WHEN DRIVING DOWNHILL, NEVER RIDE WITH THE ENGINE TURNED OFF.**

**WHEN RIDING ON WET SURFACES OR SURFACES WITH POOR GRIP (SNOW, ICE, MUD, ETC.) USE MODERATE SPEED, AVOID SUDDEN BRAKING OR MANOEUVRES THAT MAY CAUSE TO A LOSS OF TRACTION AND POSSIBLY TO A FALL OR CRASH.**

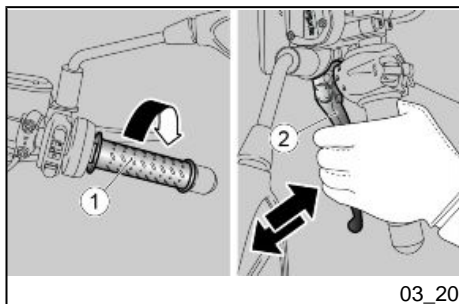

## Stopping the engine (03\_20)

- Release the throttle grip (1), brake gradually and simultaneously downshift to slow down.

### Once the speed is reduced, before stopping the vehicle:

- Operate the clutch lever (2) so that engine does not shut off.

### When the vehicle is at standstill:

- Set the gear lever to neutral ("N" on a green background).
- Release the clutch lever.
- While at a temporary halt, keep at least one of the vehicle brakes held.

### CAUTION



**WHENEVER POSSIBLE, AVOID ROUGH BRAKING, SUDDEN DECELERATION AND BRAKING IN EXCESS.**

## Parking

It is very important to select an adequate parking spot, in compliance with road signals and the guidelines described below.

### CAUTION

**PARK ON SAFE AND LEVEL GROUND TO PREVENT THE VEHICLE FROM FALLING.**

**DO NOT LEAN THE VEHICLE AGAINST A WALL OR LAY IT ON THE GROUND.**

**ENSURE THAT THE VEHICLE AND, IN PARTICULAR, PARTS OF THE VEHICLE WHICH MAY BECOME HOT (ENGINE, OIL RADIATOR AND LINES, EXHAUST SYSTEM, BRAKE DISCS) ARE NOT A HAZARD TO PERSONS OR CHILDREN.**

**DO NOT LEAVE YOUR VEHICLE UNATTENDED WITH THE ENGINE ON OR THE KEY IN THE IGNITION SWITCH.**

**CAUTION**

**IF THE VEHICLE FALLS OR IS ON A STEEP INCLINE FUEL CAN LEAK.**

**FUEL USED TO DRIVE INTERNAL COMBUSTION ENGINES IS HIGHLY FLAMMABLE AND CAN BECOME EXPLOSIVE UNDER CERTAIN CONDITIONS.**



**DO NOT REST THE RIDER OR PASSENGER WEIGHT ON THE SIDE STAND.**

### **Catalytic silencer**

The vehicle has a silencer with a "platinum - palladium - rhodium three-way" metal catalytic converter.

This device oxidises the CO (carbon monoxide) producing carbon dioxide, and the UHC (unburned hydrocarbons) producing water vapour and reduces NOx (nitrogen oxide) producing oxygen and nitrogen present in the exhaust fumes.



**DO NOT PARK THE VEHICLE NEAR DRY BRUSHWOOD OR IN PLACES EASILY ACCESSIBLE BY CHILDREN BECAUSE THE CATALYTIC CONVERTER REACHES HIGH TEMPERATURES DURING VEHICLE OPERATION; FOR THIS REASON, PAY UTMOST ATTENTION AND DO NOT TOUCH IT UNTIL IT HAS COMPLETELY COOLED DOWN.**



**DO NOT USE LEADED PETROL AS IT CAUSES IRREPARABLE DAMAGE TO THE CATALYTIC CONVERTER.**

Vehicle owners are warned that the law may prohibit the following:

- the removal of any device or element belonging to a new vehicle or any other action by anyone leading to render it non-operating, if not for maintenance, repair or replacement reasons, in order to control noise emission before the sale or delivery of the vehicle to the ultimate buyer or while it is used;
- using the vehicle after that device or element has been removed or rendered non-operating.

Check the muffler/exhaust silencer and the silencer pipes, make sure there are no signs of rust or holes and that the exhaust system works properly.

If you not an increase in exhaust noise, take your vehicle to an Official **Aprilia** Dealer at once.

**NOTE**

**DO NOT TAMPER WITH THE EXHAUST SYSTEM.**

**Stand (03\_21)**

If it is necessary to extend the side stand for any reason (e.g. after moving the vehicle), proceed as follows:

- Select an appropriate parking spot.
- Grip the left grip (1) and keep your right hand on the upper rear part of the vehicle (2).
- Lower the side stand with your right foot, fully extending it.
- Lean the motorcycle until the stand touches the ground.
- Turn the handlebar completely to the left.

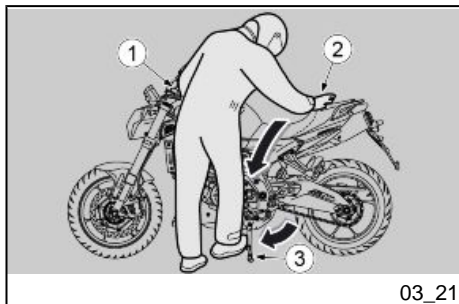



**MAKE SURE THAT THE GROUND ON WHICH THE MOTORCYCLE IS PARKED IS FIRM, EVEN AND FREE OF OBSTACLES.**

## **Suggestion to prevent theft**

### **CAUTION**

**WHEN USING A DISC LOCKING DEVICE, PAY UTMOST ATTENTION TO REMOVE IT BEFORE RIDING. FAILURE TO OBSERVE THIS WARNING MAY CAUSE SERIOUS DAMAGE TO THE BRAKING SYSTEM AND ACCIDENTS WITH CONSEQUENT PHYSICAL INJURIES OR EVEN DEATH.**

NEVER leave the ignition key in the lock and always use the steering lock. Park the vehicle in a safe place such as a garage or a place with guards. Whenever possible, use an additional anti-theft device. Make sure all vehicle documents are in order and the road tax paid. Write down your personal details and telephone number on this page to help identifying the owner in case of vehicle retrieval after a theft.

LAST NAME: .....

NAME: .....

ADDRESS: .....

TELEPHONE NO.: .....

### **WARNING**

**IN MANY CASES, STOLEN VEHICLES CAN BE IDENTIFIED BY DATA IN THE USE / MAINTENANCE BOOKLET.**



## Safe driving

Some simple tips are provided below that will enable you to use your motorcycle on a daily basis in greater safety and peace of mind. Your mechanical knowledge and ability are the foundation for safe driving. We recommend trying out the motorcycle in traffic-free zones to familiarise with it.

1. Before riding off, remember to put the helmet on and fasten it correctly.
2. Slow down and drive carefully over bumpy roads.
3. After driving over a long stretch of wet road without using the brakes, braking will not be as efficient the first time/s you use them again. When driving under conditions like this, you should brake periodically.
4. Although the vehicle is equipped with an ABS system, pay attention when braking on wet surfaces, on dirt or on a slippery road surface.
5. Do not start off by getting on the vehicle while it is standing on its stand.
6. When riding on roads covered with sand, mud, snow mixed with salt, etc. We recommend cleaning the brake discs frequently with a non-corrosive detergent in order to prevent corrosive particles from building up in the holes, which may cause early brake pad wear.

### CAUTION

**ALWAYS RIDE WITHIN YOUR LIMITS. RIDING UNDER THE INFLUENCE OF ALCOHOL OR OTHER DRUGS AND CERTAIN MEDICINES IS EXTREMELY DANGEROUS.**

### CAUTION

**ANY ELABORATION THAT MODIFIES THE VEHICLE'S PERFORMANCES, SUCH AS TAMPERING WITH ORIGINAL STRUCTURAL PARTS IS STRICTLY FORBIDDEN BY LAW, AND RENDERS THE MOTORCYCLE NO LONGER CONFORMING TO THE APPROVED TYPE AND DANGEROUS FOR RIDING.**

### CAUTION

**DO NOT ADJUST THE MIRRORS WHILE DRIVING. THIS COULD CAUSE YOU TO LOOSE CONTROL OF THE MOTORCYCLE.**

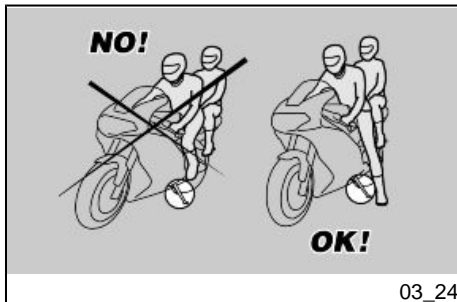
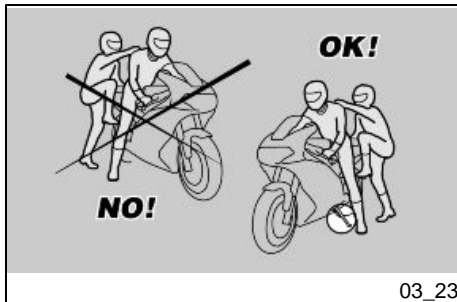
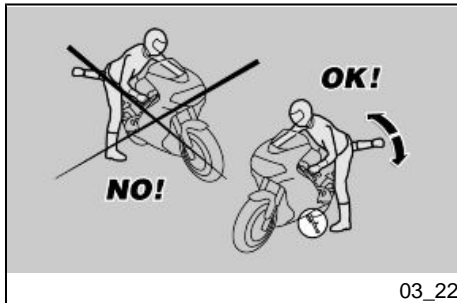

## Basic safety rules (03\_22, 03\_23, 03\_24, 03\_25, 03\_26)

The following recommendations should receive your maximum attention, because they are provided to increase your safety, and decrease damage to people, things and vehicles, in the case of a fall of the rider or passenger from the vehicle and/or from the fall or overturning of the vehicle.

Mounting and dismounting the vehicle should always be performed with total freedom of movement and with the hands free of all objects. (i.e.- objects, helmet, gloves, or glasses).

Mount and dismount only on the left side of the vehicle, and only with the side stand lowered.

The stand is designed to support the weight of the vehicle and a small additional weight, which does not include the rider and passenger.

Mounting into driving position, with the side stand in place, is permitted only to prevent the possibility of the vehicle falling or overturn, and does not indicate the possibility for the rider and passenger's weight to be placed on the side stand.

During mounting and dismounting the vehicle's weight can cause a loss of balance, with consequent loss of equilibrium and the possibility of falling or overturning.

**CAUTION**

THE RIDER SHOULD ALWAYS BE THE FIRST TO MOUNT AND THE LAST TO DISMOUNT FROM THE VEHICLE, AND SHOULD CONTROL THE STABILITY AND EQUILIBRIUM OF THE VEHICLE WHILE THE PASSENGER IS MOUNTING AND DISMOUNTING

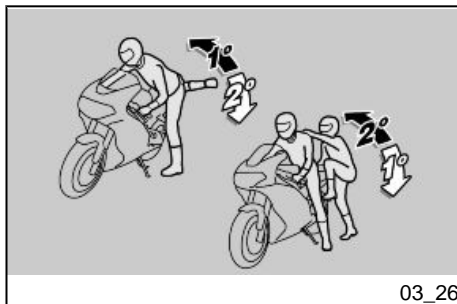

In any case, the passenger should mount and dismount the vehicle using caution to avoid causing the vehicle or the rider to lose balance.

**CAUTION**

THE RIDER TO INSTRUCT THE PASSENGER ABOUT THE PROPER WAY TO MOUNT AND DISMOUNT FROM THE VEHICLE.

THE VEHICLE INCLUDES PASSENGER FOOTRESTS WHICH SHOULD BE USED DURING MOUNTING AND DISMOUNTING. THE PASSENGER SHOULD ALWAYS USE THE LEFT FOOTREST FOR MOUNTING AND DISMOUNTING FROM THE VEHICLE.

**DO NOT DISMOUNT OR EVEN ATTEMPT TO DISMOUNT BY JUMPING OR STRETCHING OUT YOUR LEG IN ORDER TO TOUCH THE GROUND. IN BOTH CASES THE STABILITY AND EQUILIBRIUM OF THE VEHICLE COULD BE COMPROMISED.**

#### **CAUTION**

**BAGGAGE OR OBJECTS ATTACHED TO THE REAR PART OF THE VEHICLE CAN CREATE AN OBSTACLE DURING MOUNTING AND DISMOUNTING FROM THE VEHICLE.**

**IN ALL CASES, THINK AHEAD AND MOVE YOUR RIGHT LEG CAREFULLY, AS IT WILL HAVE TO AVOID AND CLEAR THE REAR PART OF THE VEHICLE (INCLUDING BAGGAGE AND THE TAIL FAIRING) WITHOUT CAUSING LOSS OF BALANCE.**

#### **MOUNTING**

- Grip the handlebar properly and mount the vehicle without placing your weight upon the side stand.

#### **CAUTION**

**IN THE CASE THAT YOU ARE NOT ABLE TO REST BOTH FEET ON THE GROUND, PUT THE RIGHT FOOT ON THE GROUND, (IN THE CASE OF A LOSS OF BALANCE THE LEFT SIDE IS "PROTECTED" BY THE SIDE STAND) AND KEEP YOUR LEFT FOOT READY TO BE POSITIONED.**

- Place both feet on the ground and straighten the vehicle into the driving position, always maintaining its equilibrium.

#### **CAUTION**

**THE RIDER SHOULD NOT OPEN OR TRY TO OPEN THE PASSENGER FOOTRESTS FROM THE RIDER'S SEAT, AS IT COULD COMPROMISE THE STABILITY AND EQUILIBRIUM OF THE VEHICLE.**

- Have the passenger open the two passenger foot pegs.
- Show the passenger how to mount the vehicle.
- Use your left foot to push on the side stand and make it fully return to its position.

#### **DISMOUNTING**

- Select an appropriate parking spot.
- Stop the vehicle.
- Switch off the engine.



**MAKE SURE THAT THE GROUND ON WHICH THE MOTORCYCLE IS PARKED IS FIRM, EVEN AND FREE OF OBSTACLES.**

- Use the heel of your left foot to completely open the side stand.

#### **CAUTION**

**IN THE CASE THAT YOU ARE NOT ABLE TO REST BOTH FEET ON THE GROUND, PUT THE RIGHT FOOT ON THE GROUND, (IN THE CASE OF A LOSS OF BALANCE THE LEFT SIDE IS "PROTECTED" BY THE SIDE STAND) AND KEEP YOUR LEFT FOOT READY TO BE POSITIONED.**

- Place both feet on the ground and keep the vehicle balanced in the driving position.
- Show the passenger how to dismount from the vehicle.



**RISK OF FALLING OR OVERTURNING.**

**MAKE SURE THAT THE PASSENGER HAS DISMOUNTED FROM THE VEHICLE.  
DO NOT PLACE YOUR WEIGHT UPON THE SIDE STAND.**

- Lean the motorcycle until the stand touches the ground.
- Correctly grip the handlebar, and dismount from the vehicle.
- Turn the handlebar completely to the left.
- Place the passenger footrest in its place.

**CAUTION**



**MAKE SURE THE VEHICLE IS STABLE.**

# SHIVER 900



## Chap. 04 Maintenance

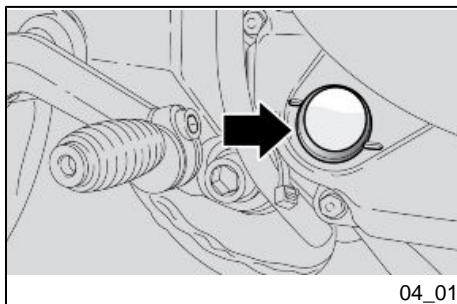

## Foreword

### WARNING

THE ELECTRONIC CONTROL SYSTEM OF THIS VEHICLE IDENTIFIES FAULTS IN REAL TIME AND STORES THEM IN ITS MEMORY FOR SUBSEQUENT READING WITH THE DIAGNOSTIC SYSTEM USED BY Authorised Aprilia Dealers.

### Engine oil level check (04\_01)

Check the engine oil level frequently.

### NOTE

CARRY OUT MAINTENANCE OPERATIONS AT HALF THE INTERVALS SPECIFIED IF THE VEHICLE IS USED IN PARTICULAR RAINY OR DUSTY CONDITIONS, OFF ROAD OR FOR TRACK USE.



THE OIL LEVEL MUST BE CHECKED WHEN THE ENGINE IS WARM.

### CAUTION

DO NOT LET THE ENGINE IDLE WITH THE VEHICLE AT A STANDSTILL TO WARM UP THE ENGINE AND OBTAIN THE OPERATING TEMPERATURE OF ENGINE OIL.

PREFERABLY CHECK THE OIL AFTER A JOURNEY OF AFTER TRAVELLING APPROXIMATELY 15 Km (10 miles) IN EXTRA-URBAN CONDITIONS (ENOUGH TO WARM UP THE ENGINE OIL TO OPERATING TEMPERATURE).

- Shut off the engine.
- Keep the vehicle upright with both wheels on the earth.



- Using the relative opening on the engine casing, check the oil level.

**MAX** (top notch) = maximum level.

**MIN** (bottom notch) = minimum level

- The level is correct if it reaches the "**MAX**" level.

## Engine oil top-up (04\_02)

If the engine oil needs to be topped up, proceed as follows:

- Unscrew and remove the cap.

### CAUTION

**ONLY USE ENGINE OIL RECOMMENDED ON THE PRODUCTS TABLE.**

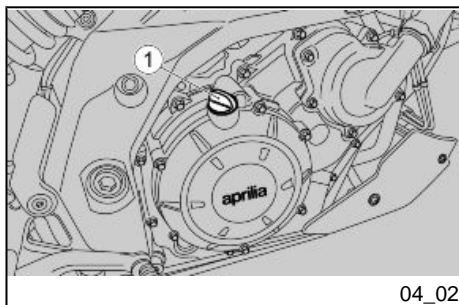

04\_02

- Pour in the necessary quantity of engine oil to reach the correct level.

### CAUTION

**DO NOT ADD ADDITIVES OR ANY OTHER SUBSTANCES TO THE OIL. WHEN USING A FUNNEL OR ANY OTHER ELEMENT, MAKE SURE IT IS PERFECTLY CLEAN.**

## Engine oil change

### CAUTION

**THE ENGINE OIL MAY ONLY BE CHECKED AND CHANGED BY AN Authorised Aprilia Dealer**

## Engine oil filter replacement

### CAUTION

**THE ENGINE OIL FILTER MAY ONLY BE CHECKED AND CHANGED BY AN Authorised Aprilia Dealer**

## Tyres

This vehicle is fitted with tubeless tyres (without inner tubes).

### CAUTION

**CHECK TYRE INFLATION PRESSURE REGULARLY AT AMBIENT TEMPERATURE. THE MEASUREMENT MAY BE INCORRECT IF TYRES ARE WARM. CHECK TYRE PRESSURE MAINLY BEFORE AND AFTER A LONG TRIP. AN OVER-INFLATED TYRE WILL PROVIDE A HARSH RIDE AS SURFACE UNEVENNESS IS NOT CUSHIONED AND IS SENT TO THE HANDLEBAR, THUS REDUCING GRIP AND ROAD HOLDING SPECIALLY WHEN CORNERING.**

**ON THE OTHER HAND, AN UNDER-INFLATED TYRE CAUSES THE CONTACT PATCH TO INCLUDE A LARGER PORTION OF THE TYRE SIDE WALLS. IF SO, THE TYRE MIGHT SLIP ON OR GET DETACHED FROM THE WHEEL RIM, RESULTING IN LOSS OF CONTROL OVER THE VEHICLE.**

**EVENTUALLY THE VEHICLE MIGHT SKID IN A BEND.**

**CHECK THE SURFACE CONDITION AND WEAR BECAUSE POOR TYRE CONDITION COULD COMPROMISE GRIP AND HANDLING OF THE VEHICLE.**

**SOME TYRE TYPES APPROVED FOR THIS VEHICLE FEATURE WEAR INDICATORS.**

**THERE ARE SEVERAL TYPES OF WEAR INDICATORS. CONSULT YOUR DEALER ON METHODS TO CHECK FOR WEAR.**

**CARRY OUT A VISUAL INSPECTION FOR TYRE WEAR AND TEAR, REPLACE TYRES WHEN WORN.**

WHEN TYRES ARE OLD, THE MATERIAL MAY HARDEN AND NOT PROVIDE ADEQUATE ROAD HOLDING, EVEN IF TYRES ARE STILL WITHIN THE WEAR LIMIT. REPLACE TYRES IF THIS OCCURS. REPLACE THE TYRE IF IT IS WORN OR IF THERE IS A PUNCTURE LARGER THAN 5 mm (0.197 in) IN THE TREAD AREA.

WHEEL MUST BE BALANCED AFTER A TYRE IS MENDED.

USE ONLY TYRE SIZES INDICATED BY THE MANUFACTURER. DO NOT FIT TYRES WITH INNER TUBES ON RIMS FOR TUBELESS TYRES OR VICE VERSA. CHECK THAT THE INFLATION VALVES HAVE THEIR CAPS FITTED TO AVOID UNEXPECTED FLAT TYRES.

REPLACEMENT, REPAIR, MAINTENANCE AND BALANCING OPERATIONS ARE HIGHLY IMPORTANT AND SO THEY SHOULD BE CARRIED OUT USING THE SPECIFIC TOOLS AND WITH THE ADEQUATE KNOWLEDGE. HAVE YOUR TYRES AND WHEELS SERVICED AT AN AUTHORISED DEALER OR A SPECIALISED TYRE WORKSHOP.

NEW TYRES MAY BE COATED WITH AN OILY FILM: RIDE WITH CAUTION DURING THE FIRST KILOMETRES. DO NOT APPLY UNSUITABLE LIQUIDS ON TYRES.

#### Minimum tread depth:

front and rear: 2 mm (0.079 in) (USA 3 mm) (USA - 0.118 in), and never less than specified by applicable legislation in the country in which the vehicle is used.

## Spark plug dismantlement

### CAUTION

THE SPARK PLUGS MAY ONLY BE CHECKED, CLEANED AND CHANGED BY AN Authorised Aprilia Dealer

## Removing the air filter

### CAUTION

**THE AIR FILTER MAY ONLY BE CHECKED AND CHANGED BY AN Authorised Aprilia Dealer**

## Cooling fluid level

Do not use the vehicle if the coolant level is below the minimum marking.

### CAUTION



**COOLANT IS TOXIC IF INGESTED; CONTACT WITH YOUR EYES OR SKIN MAY CAUSE IRRITATION. IF THE FLUID GETS IN CONTACT WITH THE EYES OR SKIN, RINSE REPEATEDLY WITH PLENTY OF WATER AND SEEK MEDICAL ADVICE. IF SWALLOWED, INDUCE VOMITING, RINSE MOUTH AND THROAT WITH PLENTY OF WATER AND SEEK MEDICAL ADVICE IMMEDIATELY.**

Coolant solution is 50% water and 50% antifreeze fluid.

This mixture is suitable for the majority of operating temperatures and offers adequate corrosion protection.

It is advisable to use the same mixture even in hot weather as this minimises loss due to evaporation and the need of frequent top-ups.

This reduces the quantity of salt deposits left in the radiator by evaporating water to ensure constant cooling system performance.

If the external temperature drops below 0°C (32°F), check the cooling circuit frequently and, if necessary, increase the concentration of antifreeze (up to a maximum of 60%).

Use distilled water in the coolant mixture to avoid damaging the engine.

#### CAUTION



**NEVER UNDO THE RADIATOR CAP WHEN THE ENGINE IS WARM, AS THE COOLANT IS PRESSURISED AND VERY HOT. CONTACT WITH SKIN OR CLOTHES MAY CAUSE SEVERE BURNS AND/OR INJURIES.**

#### Coolant check (04\_03)

- Shut off the engine and wait until it cools off.
- Keep the vehicle upright with the wheels on the ground.
- Move the handlebar to the left while keeping the vehicle upright.
- Check that the level of the liquid in the expansion tank is between "MAX" ("MAX"= maximum level) and "MIN" ("MIN"= minimum level)

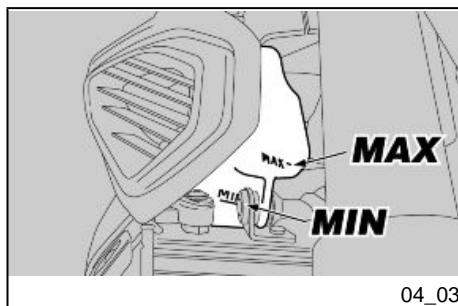

#### Coolant top-up

#### NOTE

**FOR REMOVING, CHECKING AND CHANGING THE COOLANT CONTACT AN Official Aprilia Dealer**

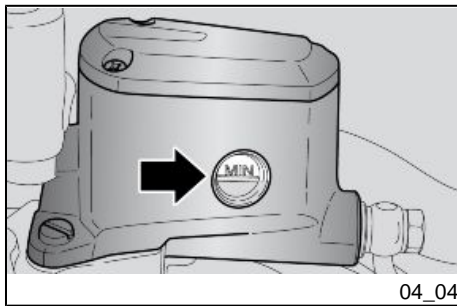

04\_04

## Checking the brake oil level (04\_04, 04\_05)

- For the front break, rest the vehicle on its stand and turn the handlebar so that the fluid in the reservoir is parallel to the reservoir edge.
- Check that the fluid in the reservoir is above the "**MIN**" reference mark.
- For the rear break, keep the vehicle upright and check that the fluid in the reservoir is parallel to the reservoir edge.
- Make sure that the fluid level in the reservoir is above the "**LOWER**" reference mark.

Top-up if the fluid does not reach at least the "**LOWER**" / "**MIN**" reference mark.

- Check brake pads and disc for wear
- If the pads and/or the disc do not need replacing, top up the fluid.

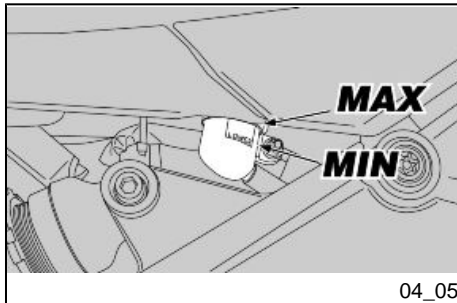

04\_05

## Braking system fluid top up

### NOTE

**FOR REMOVING, CHECKING, TOPPING UP OR CHANGING THE BRAKE OIL CONTACT AN Official Aprilia Dealer**



04\_06

## Checking clutch fluid (04\_06)

- Rest the vehicle on its stand.
- Turn the handlebar so that the fluid in the reservoir is parallel to the reservoir edge.
- Make sure that the fluid level in the reservoir is above the "MIN" reference mark:

Top-up if the fluid does not reach at least the "MIN" reference mark.

## Topping up clutch fluid

### NOTE

**FOR REMOVING, CHECKING, TOPPING UP OR CHANGING THE CLUTCH OIL CONTACT AN Official Aprilia Dealer**

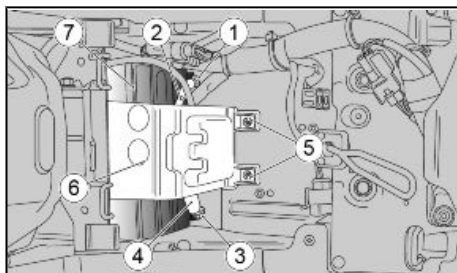

04\_07

## Battery removal (04\_07)

- Make sure that the ignition switch is set to "OFF".
- Remove the rider saddle.
- Undo and remove the screw (1) of the negative terminal (-).
- Move the negative lead (2) aside.
- Undo and remove the screw (3) of the positive terminal (+).
- Move the positive lead (4) aside.
- Undo and remove the two screws (5).
- Remove the battery locking bracket (6).
- Hold the battery (7) firmly and lift it out of its compartment.
- Put the battery (7) away on a level surface in a cool and dry place.
- Refit the rider saddle.

**CAUTION**

WHEN REFITTING THE BATTERY, MAKE SURE IT IS CORRECTLY POSITIONED AND POLES ARE NOT INVERTED.

**CAUTION**

WHEN REFITTING, CONNECT THE LEAD TO THE POSITIVE TERMINAL (+) FIRST AND AFTERWARDS THE LEAD TO THE NEGATIVE TERMINAL (-).



CHECK THAT THE CABLE TERMINALS AND BATTERY LEADS ARE:

- IN GOOD CONDITION (NOT CORRODED OR COVERED BY DEPOSITS);
- COVERED BY NEUTRAL GREASE OR PETROLEUM JELLY.

**Checking the electrolyte level****WARNING**

THIS MOTORCYCLE IS EQUIPPED WITH A BATTERY THAT REQUIRES NO MAINTENANCE OTHER THAN PERIODICALLY CHECKING STATE OF CHARGE.

**Charging the battery**

- Remove the battery.
- Get an adequate battery charger.
- Set the battery charger for the recharge type indicated.
- Connect the battery to the battery charger.



**CAUTION**

**WHEN RECHARGING OR USING THE BATTERY, BE CAREFUL TO HAVE THE ROOM ADEQUATELY AIRED. DO NOT BREATHE GASES RELEASED WHEN THE BATTERY IS RECHARGING.**

Switch on the battery charger.

**Characteristic****CHARGE MODES**

Recharge - Ordinary

Current - 1.0A

Time - 8-10 hours

Charging - Quick

Current - 10A

Time - 1 hour

**Long periods of inactivity**

**IF THE VEHICLE IS INACTIVE FOR MORE THAN FIFTEEN DAYS, DISCONNECT THE 30A FUSE OR DISCONNECT THE BATTERY, TO AVOID THE BATTERY DETERIORATING DUE TO THE CONSUMPTION OF CURRENT BY THE MULTI-FUNCTION COMPUTER.**

**CAUTION****REMOVING THE 30A FUSE RESETS THE DIGITAL CLOCK:**

If the vehicle is inactive longer than fifteen days, it is necessary to recharge the battery to avoid sulphation.

- Remove the battery.

In winter or when the vehicle is out of use for prolonged periods, check charge level frequently (about once a month) to prevent deterioration.

- Recharge it fully with an ordinary charge.

If the battery is still on the vehicle, disconnect the cables from the terminals.

**Fuses (04\_08, 04\_09, 04\_10, 04\_11, 04\_12, 04\_13)**

Check fuses in case of failure or irregular functioning of an electrical component or engine starting failure.

Check the auxiliary 15A fuses first, then the main 30A fuse.

**CAUTION**

**DO NOT ATTEMPT TO REPAIR FAULTY FUSES.**

**NEVER USE A FUSE THAT IS DIFFERENT THAN WHAT IS SPECIFIED TO PREVENT DAMAGES TO THE ELECTRICAL SYSTEM OR SHORT CIRCUITS, AND THE RISK OF FIRE.**

**CAUTION**

**A FUSE THAT BLOWS FREQUENTLY MAY INDICATE A SHORT CIRCUIT OR OVERLOAD. CONTACT AN authorised aprilia Dealer.**

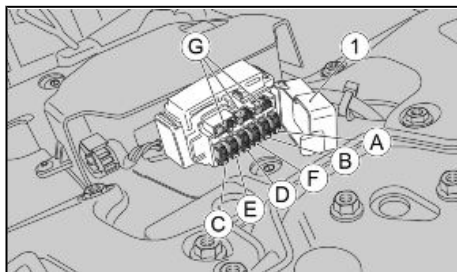

04\_08

## SECONDARY FUSES

Before replacing the fuse, find, if possible, the cause of the problem.

To check the secondary fuses:

- To avoid an accidental short-circuit, place the power switch to "OFF".
- Remove the rider saddle.
- Open the cover of the secondary fuse box (1).
- Take out one fuse at a time and check whether the filament (2) is broken. In this case change the fuse with one of the same amperage.

### NOTE

**IF THE SPARE FUSE IS USED, REPLACE WITH ONE OF THE SAME TYPE IN THE CORRESPONDING FITTING.**

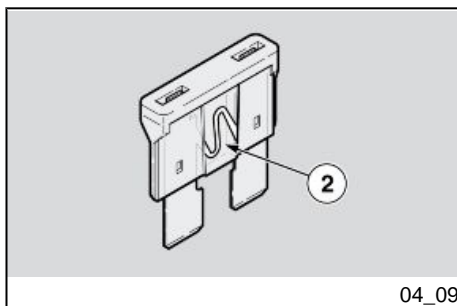

04\_09

## AUXILIARY FUSES DISTRIBUTION

A) 10A fuse	Lights relay/high beam relay, buttons and brake lights/horn, daylight running lights (front, rear)/ license plate
B) 15A fuse	ECU live positive lead
F) 7,5A fuse	ECU permanent positive lead

D) 15A fuse	Coils, injectors, fuel pump, secondary injection relay
E) 15A fuse	Low beam/high beam lights
C) 7.5A fuse	Fan
G) spare fuses	-

*Auxiliary fuses are placed in the central part of the motorcycle, under the rider saddle.*

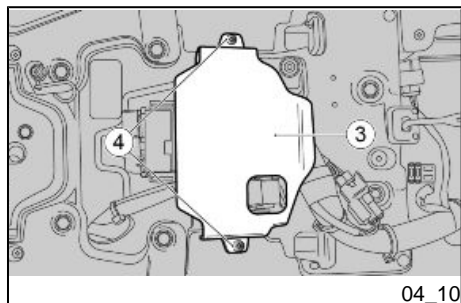

#### **MAIN FUSES**

To check the main fuse (H)

- Remove the protective cover (3), unscrewing the two screws (4).

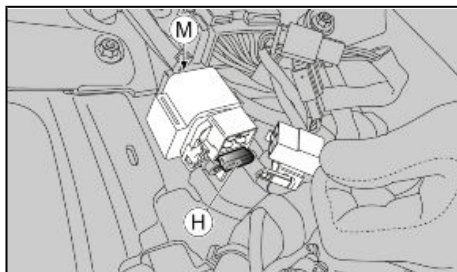

04\_11

- Remove the protective cover, take out the fuse (H) and check whether the filament (2) is broken. In this case change it with one of the same amperage.

#### CAUTION

**REMOVING THE 30A FUSE RESETS THESE FUNCTIONS ON THE DASHBOARD:**

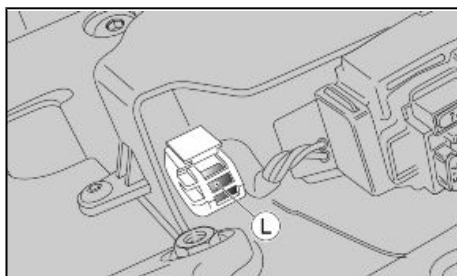

04\_12

To check the main fuse (L)

- Remove the protective cover, take out the fuse (L) and check whether the filament (2) is broken. In this case change it with one of the same amperage.

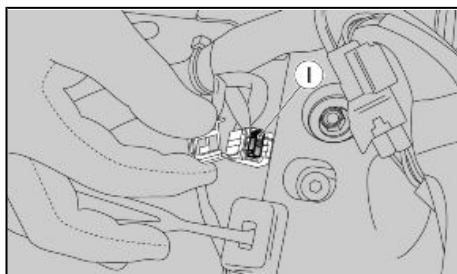

04\_13

To check the ABS fuse (I)

- Remove the protective cover, take out the fuse (I) and check whether the filament (2) is broken. In this case change it with one of the same amperage.

## **MAIN FUSES DISTRIBUTION**

H) 30A fuse	Recharge, "F-D-C positive fuses", key positive, main relay, 5A positive fuse (dashboard)
I) 20A fuse	ECU ABS permanent positive
L) 5A fuse	dashboard permanent positive
M) spare fuse	-

*The main fuses are located in the central part of the motorcycle, under the rider saddle.*

### **Lamps**

#### **NOTE**

**WHEN THE REAR WHEEL EXCEEDS THE SPEED OF 1 km/h (0.62 mph) (EVEN WITH THE ENGINE OFF, AND THE KEY SET TO ON), THE HEADLIGHTS WILL TURN ON AND WILL REMAIN ON FOR 30 SECONDS (FROM THE TIME IN WHICH THE REAR WHEEL STOPS MOVING).**

#### **CAUTION**

**FOR REMOVAL, CHECKING, AND REPLACEMENT OF THE SPARK PLUGS CONTACT AN Official Aprilia Dealer.**

## Headlight adjustment (04\_14, 04\_15, 04\_16)

### NOTE

**IN COMPLIANCE WITH LOCAL LEGISLATION, SPECIFIC PROCEDURES MUST BE FOLLOWED WHEN ALIGNING THE LIGHTS.**

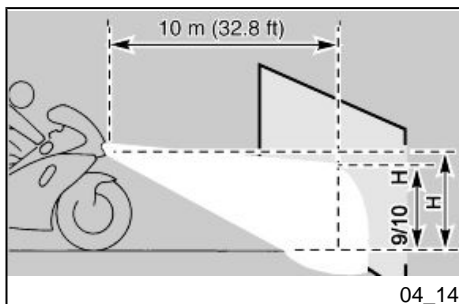

For a quick check that the front light beam is directed properly, place the vehicle 10 m (32.8 ft) from a vertical wall, making sure the ground is flat, sit on the vehicle and check that the beam projected onto the wall is just under the horizontal straight line of the headlight (about 9/10 of the total height).

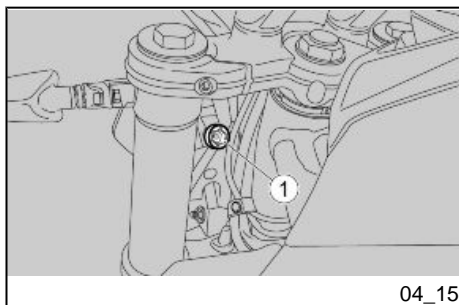

### To carry out vertical adjustment of the light beam:

- Rest the vehicle on its stand.
- Working from the rear left of the top fairing, use the knob (1). **TIGHTEN** (clockwise) to raise the beam. **UNSCREW** (anticlockwise) to lower the light beam.

### NOTE

**CHECK THAT THE LIGHT BEAM VERTICAL DIRECTION IS CORRECT.**

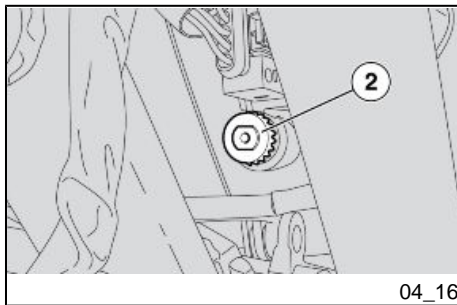

**In order to carry out horizontal adjustment of the light beam:**

- Rest the vehicle on its stand.
- Working from the rear left of the top fairing, use the knob (2). **TIGHTEN** (clockwise) to shift the beam to the left. **UNSCREW** (anticlockwise) to shift the beam to the right.

**NOTE**

**CHECK THAT THE LIGHT BEAM HORIZONTAL DIRECTION IS CORRECT.**

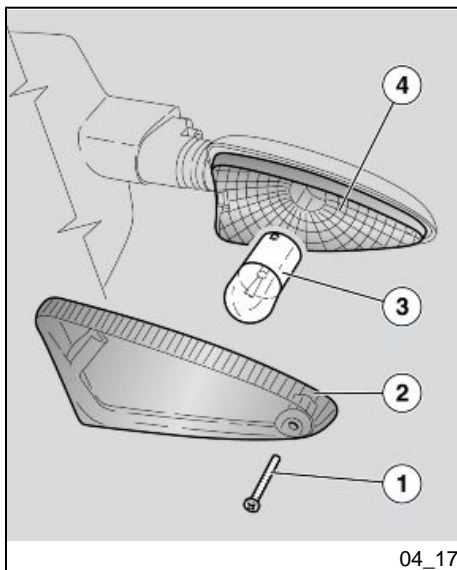

**Front direction indicators (04\_17)**

- Rest the vehicle on its stand.
- Loosen and remove screw (1).
- Remove the lens (2).
- Press bulb (3) slightly and turn it anticlockwise.
- Pull the bulb (3) out of its fitting.
- Insert a bulb of the same type adequately.

**WARNING**

**IF THE REFLECTOR (4) DETACHES FROM ITS SEAT, PUSH IT CORRECTLY INTO PLACE.**



## Rear optical unit

### CAUTION

THE TAIL LIGHT ASSEMBLY MUST BE REMOVED, CHECKED AND, IF NECESSARY, REPLACED BY AN Authorised Aprilia Dealer.

### Rear turn indicators (04\_18)

- Rest the vehicle on its stand.
- Loosen and remove screw (1).
- Remove the lens (2).
- Press bulb (3) slightly and turn it anticlockwise.
- Pull the bulb (3) out of its fitting.
- Insert a bulb of the same type adequately.

### WARNING

IF THE REFLECTOR (4) DETACHES FROM ITS SEAT, PUSH IT CORRECTLY INTO PLACE.

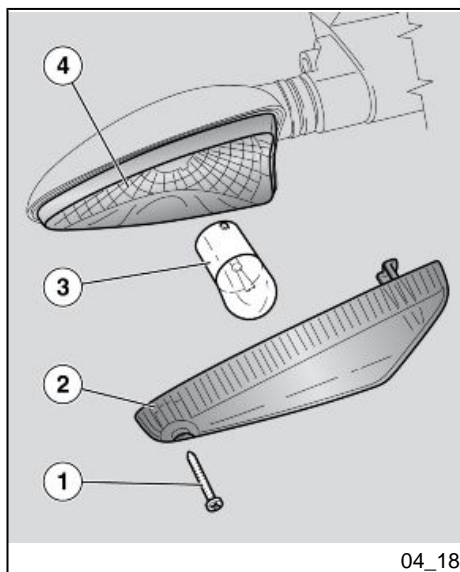

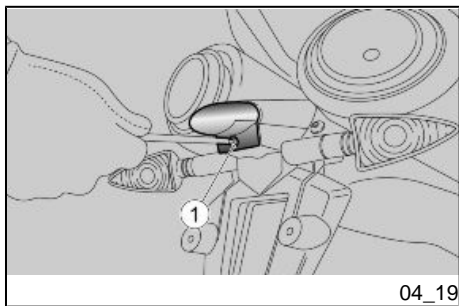

### Number plate light (04\_19, 04\_20)

- Rest the vehicle on its stand.
- Unscrew and remove the fixing screw (1) and collect the nut.

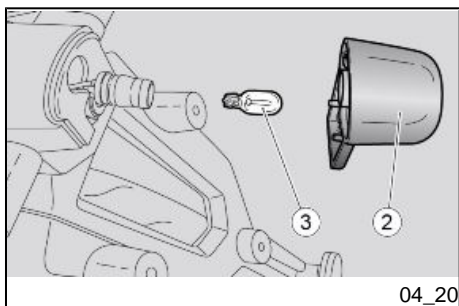

- Take out the glass of the license plate light (2).
- Remove the bulb (3) and replace it with another of the same type.

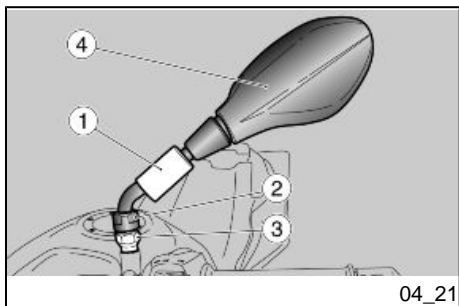

### Rear-view mirrors (04\_21, 04\_22)

- Park the vehicle on its centre stand on safe and level ground.
- Move the protection casing (1).



**HOLD THE REAR-VIEW MIRROR (4) TO AVOID DROPPING IT BY ACCIDENT.**

- Keep the screw (2) blocked and completely unscrew the nut (3).



**HANDLE PLASTIC AND PAINTED COMPONENTS WITH CARE, DO NOT SCRATCH OR SPOIL THEM.**

- Remove the rear-view mirror (4).

**CAUTION**

**REPEAT THE PROCEDURE TO REMOVE THE OTHER MIRROR.**



**AFTER REFITTING, ADJUST THE REAR-VIEW MIRRORS CORRECTLY AND TIGHTEN THE NUTS IN ORDER TO ENSURE STABILITY.**

**After refitting:**

- Adjust the rear-view mirror angle correctly.

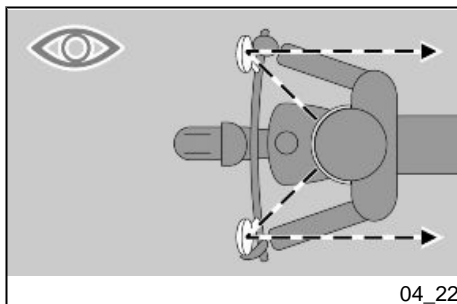

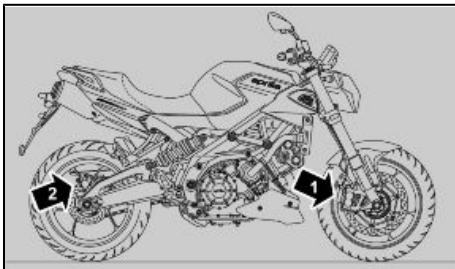

04\_23

## Front and rear disc brake (04\_23, 04\_24, 04\_25)

### CAUTION



**CHECK BRAKE PADS FOR WEAR MAINLY BEFORE EACH RIDE.**

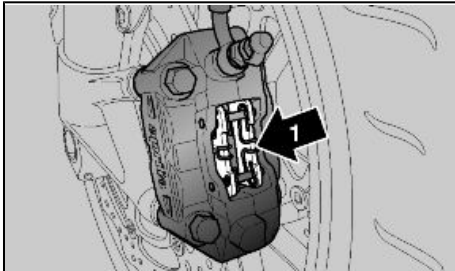

04\_24

### To perform a quick pad wear check:

- Rest the vehicle on its stand.
- Carry out a visual inspection of brake disc and pads as follows:
  - at the rear, for the front brake callipers (1);
  - on the right side of the motorcycle, from the top downwards for the rear brake calliper (2).

### CAUTION

**EXCESSIVE WEAR OF THE FRICTION MATERIAL MAKES THE PAD METAL SUPPORT GET INTO CONTACT WITH THE DISC, WHICH RESULTS IN A METALLIC NOISE AND SPARKS IN THE CALLIPER; THEREFORE, BRAKING EFFICIENCY AND DISC SAFETY AND INTEGRITY ARE AT RISK.**

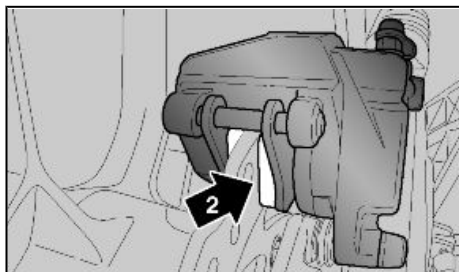

04\_25

If the thickness of the friction material (even just one front or rear pad) is reduced to a value of about **1.5 mm (0.06 in)** (or even if just one of the wear indicators is no longer visible), contact an Official **Aprilia** Dealer to replace all the brake pads.

**USE ONLY ORIGINAL BRAKE PADS.**

**THE USE OF BRAKE PADS OTHER THAN ORIGINAL ONES CAN COMPROMISE PERFORMANCE AND/OR DAMAGE THE BRAKING SYSTEM.**

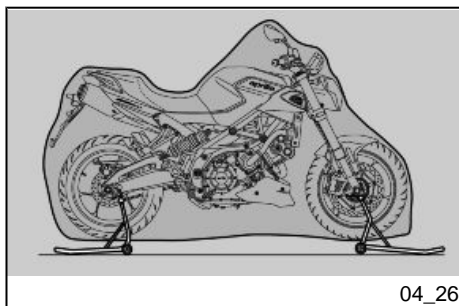

04\_26

### Periods of inactivity (04\_26)

Take some measures to avoid the side effects of not using the scooter. Besides, it is necessary to carry out general repairs and checks before garaging the motorcycle as one can forget to do so afterwards.

Proceed as follows:

- Remove the battery.
- Wash and dry the motorcycle.
- Polish the painted surfaces.
- Inflate the tyres.
- Set the vehicle in a room with no heating or humidity, with minimum temperature variations and not exposed to sun rays.
- Wrap and tie a plastic bag around the exhaust pipe ends to keep moisture out.

#### NOTE

**USE A SUITABLE SUPPORT TO LIFT THE VEHICLE WITH BOTH TYRES OFF THE GROUND.**

- Place the vehicle on the specific front stand (optional) and rear stand (optional).

- Cover the vehicle (do not use plastic or waterproof materials).

## AFTER STORAGE

### NOTE

**TAKE THE PLASTIC BAGS OFF THE EXHAUST PIPE OPENING.**

- Uncover and clean the vehicle.
- Check the battery for correct charge and install it.
- Refill the fuel tank.
- Carry out the pre-ride checks.

### CAUTION



**AS A TEST, RIDE THE MOTORCYCLE FOR A FEW KILOMETRES AT A MODERATE SPEED AND AWAY FROM TRAFFIC AREAS.**

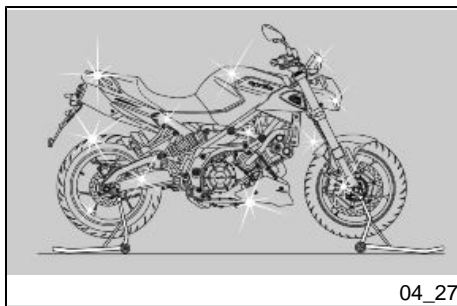

04\_27

## Cleaning the vehicle (04\_27, 04\_28, 04\_29)

**Clean the motorcycle frequently if exposed to adverse conditions, such as:**

- Air pollution (cities and industrial areas).
- Salinity and humidity in the atmosphere (seashore areas, hot and wet weather).
- Special environmental/seasonal conditions (use of salt, anti-icing chemical products on the roads in winter).
- Always clean off any smog and pollution residue, tar stains, insects, bird droppings, etc. from the bodywork.
- Avoid parking the vehicle under trees. During some seasons, resins, fruits or leaves containing aggressive chemical substances that may damage the paintwork may fall from trees.

- Clean the dashboard with a soft, damp cloth.

**CAUTION**

**BEFORE WASHING THE VEHICLE, COVER THE ENGINE AIR INTAKES AND THE EXHAUST PIPES.**

**CAUTION**

**AFTER CLEANING YOUR MOTORCYCLE, BRAKING EFFICIENCY MAY BE TEMPORARILY AFFECTED DUE TO THE PRESENCE OF WATER ON THE FRICTION SURFACES OF THE BRAKING CIRCUIT. ALLOW LONGER BRAKING DISTANCES TO PREVENT ACCIDENTS. BRAKE REPEATEDLY TO RESTORE NORMAL OPERATION. CARRY OUT THE PRE-RIDE CHECKS.**

**CAUTION****WARNING**

**DOPO UNA PIOGGIA BATTENTE, DOPO UN LAVAGGIO O NEL CASO DI REPENTINI SBALZI TERMICI, LE LENTI DEL GRUPPO OTTICO ANTERIORE POSSONO APPANNARSI.**

**QUESTA CONDIZIONE È DOVUTA ALLA DIFFERENZA DI TEMPERATURA FRA ESTERNO ED INTERNO E NON È INDICATIVA DI UN PROBLEMA DEL GRUPPO OTTICO ANTERIORE.**

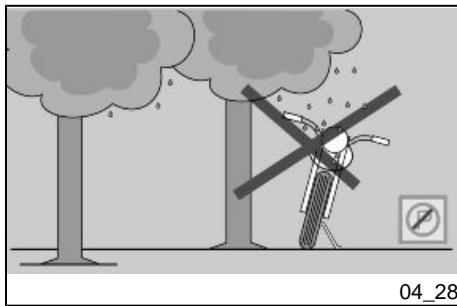

04\_28

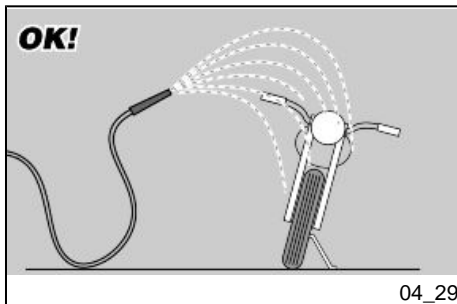

04\_29

To remove dirt and mud accumulated on painted surfaces, wet the soiled areas thoroughly with a low-pressure water jet, then remove dirt and mud with a soft car body sponge soaked abundantly in a solution of car body shampoo in water (2 - 4% shampoo dissolved in water). Then rinse with plenty of water, and dry with a chamois leather. To clean the engine outer parts, use degreasing detergent, brushes and old cloths. Wash anodised or painted aluminium parts with neutral soap and water. Using aggressive detergents may damage the surface treatment of these components.



**TO CLEAN THE HEADLIGHTS USE A SPONGE SOAKED IN WATER AND MILD DETERGENT, RUBBING THE SURFACE GENTLY AND RINSING FREQUENTLY WITH PLENTY OF WATER. REMEMBER TO CLEAN THE VEHICLE CAREFULLY BEFORE APPLYING SILICON WAX POLISH. DO NOT POLISH MATT-PAINTED SURFACES WITH POLISHING PASTE. THE VEHICLE SHOULD NEVER BE WASHED IN DIRECT SUNLIGHT, ESPECIALLY DURING SUMMER, OR WITH THE BODYWORK STILL HOT AS THE CAR SHAMPOO CAN DAMAGE THE PAINTWORK IF IT DRIES BEFORE BEING RINSED OFF.**

#### CAUTION

**NEVER USE CLOTHS SOAKED IN PETROL, DIESEL OIL OR KEROSENE FOR CLEANING THE PAINTED OR PLASTIC SURFACES SO AS NOT TO DAMAGE THE LUSTRE FINISH OR ALTER THE MECHANICAL PROPERTIES.**

#### CAUTION



**DO NOT USE WATER (OR LIQUIDS) AT TEMPERATURES OVER 40°C (104°F) WHEN CLEANING THE VEHICLE PLASTIC PARTS. DO NOT AIM HIGH PRESSURE AIR/WATER JETS OR STEAM JETS DIRECTLY ON THESE COMPONENTS. DO NOT USE ALCOHOL OR SOLVENTS TO CLEAN ANY RUBBER OR PLASTIC SADDLE COMPONENTS USE WATER AND MILD SOAP.**



**CAUTION**

**DO NOT USE SOLVENTS OR PETROL BY-PRODUCTS (ACETONE, TRICHLOROETHYLENE, TURPENTINE, PETROL, THINNERS) TO CLEAN THE SADDLE. USE INSTEAD DETERGENTS WITH SURFACE ACTIVE AGENTS NOT EXCEEDING 5% (NEUTRAL SOAP, DEGREASING DETERGENTS OR ALCOHOL).**

**DRY THE SADDLE WELL AFTER CLEANING.**

**CAUTION**

**DO NOT APPLY PROTECTIVE WAX ON THE SADDLE AS IT MAY BECOME SLIPPERY.**

Lubricate the following components after washing the vehicle:

- drive chain;
- lever controls;
- pedal controls;
- ignition switch.

**Transport (04\_30)****NOTE**

**BEFORE TRANSPORTING THE VEHICLE, THE FUEL TANK MUST BE EMPTIED ADEQUATELY AND YOU MUST CHECK THAT IT IS COMPLETELY DRY.**

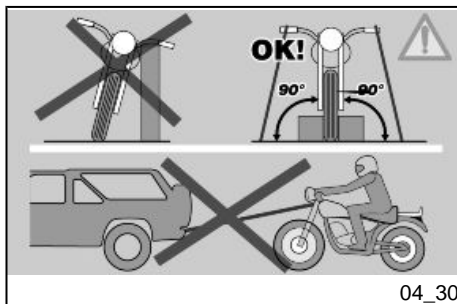

**DURING TRANSPORT, THE VEHICLE SHOULD BE UPRIGHT AND SECURELY ANCHORED AND SHOULD HAVE THE FIRST GEAR ENGAGED SO AS TO AVOID POSSIBLE FUEL, OIL OR COOLANT LEAKS.**

**IN CASE OF FAILURE, DO NOT TOW THE VEHICLE BUT CONTACT A ROAD ASSISTANCE SERVICE INSTEAD TO HAVE THE INFLAMMABLE FLUIDS DRAINED .**

- Fold the rear view mirrors inwards to reduce the risk of damage.

## Transmission chain



**AN EXCESSIVELY LOOSE DRIVE CHAIN MAY DETACH FROM THE FRONT PINION OR SPROCKET, CAUSING AN ACCIDENT OR SIGNIFICANT DAMAGES TO PERSONS AND TO THE VEHICLE. CHECK REGULARLY THE CLEARANCE OF THE DRIVE CHAIN AND ADJUST THE CHAIN IF NECESSARY. TO CHANGE THE DRIVE CHAIN, CONTACT AN Authorised Aprilia Dealer, WHICH WILL BE PLEASED TO PROVIDE YOU WITH QUICK AND THOROUGH SERVICE.**

### CAUTION



**INCORRECT MAINTENANCE MAY CAUSE EARLY WEAR OF THE DRIVE CHAIN AND/OR DAMAGE THE FRONT PINION AND/OR THE REAR SPROCKET. PERFORM DRIVE CHAIN MAINTENANCE OPERATIONS MORE FREQUENTLY IF YOU RIDE THE VEHICLE IN EXTREME CONDITIONS OR ON DUSTY AND/OR MUDDY ROADS.**

**CAUTION**

**DO NOT MODIFY THE FINAL DRIVE GEAR RATIO OR THE NUMBER OF LINKS IN THE CHAIN.**

**Characteristic****Final drive ratio**

16/44

**Type**

Endless (without chain hammerlocks) and with sealed links. No. of links 108

**Model**

525 ZRPK

**Chain backlash check (04\_31)****To check the clearance:**

- Shut off the engine.
- Rest the vehicle on its stand.
- Select neutral.
- Check that the vertical oscillation at a point between the pinion and the sprocket on the lower branch of the chain is about **25 mm (0.98 in)**.
- Move the vehicle forwards to check the vertical deflection of the chain in other positions; the chain deflection must be constant throughout the entire rotation of the wheel.

if the clearance is uniform, but greater or less than **25 mm (0.98 in)**, carry out the adjustment.

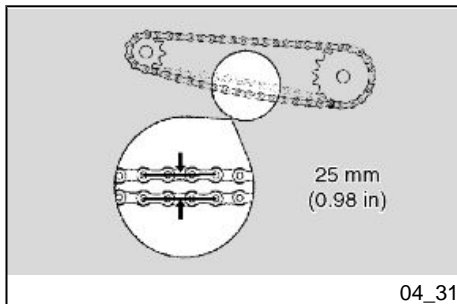

**CAUTION**

**IF THE CLEARANCE IS GREATER IN SOME POSITIONS IT MEANS THAT SOME ELEMENTS OF THE CHAIN ARE CRUSHED OR HAVE SEIZED UP. IN THIS CASE THE CHAIN SHOULD BE REPLACED.**

**LUBRICATE THE CHAIN REGULARLY TO PREVENT THE RISK OF SEIZURE.**

**Chain backlash adjustment**

**ANY WORK ON THE DRIVE CHAIN MUST BE PERFORMED BY AN Authorised Aprilia Dealer.**

**Checking wear of chain, front and rear sprockets**

Also check the following parts and check that the chain, the front sprocket and the rear sprocket do not have:

- damaged rollers.
- loosened pins.
- dry, corroded, crushed or seized links.
- excessive wear.
- Missing sealing rings.
- excessively worn or damaged front or rear sprocket teeth.

**CAUTION**

**IF THE CHAIN ROLLERS ARE DAMAGED, THE PINS ARE LOOSE AND/OR THE SEAL RINGS ARE DAMAGED OR MISSING, THE ENTIRE CHAIN UNIT (PINION, SPROCKET AND CHAIN) NEEDS TO BE REPLACED.**

**CAUTION**

**LUBRICATE THE CHAIN AT FREQUENT INTERVALS, ESPECIALLY IF ANY DRY OR CORRODED PARTS ARE NOTED. CRUSHED OR SEIZED LINKS MUST BE LUBRICATED AND RESTORED TO PROPER WORKING ORDER. IF THIS IS NOT POSSIBLE, HAVE THE CHAIN REPLACED BY AN Authorised Aprilia Dealer.**

**Chain lubrication and cleaning**

Do not wash the chain using water jets, vapour jets, high-pressure water jets or highly flammable solvents.

- Wash the chain with fuel oil or kerosene. Maintenance operations should be more frequent if there are signs of early rust.

Lubricate the chain whenever necessary.

- After washing and drying the chain, lubricate it with spray grease for sealed chains.



**THE DRIVE CHAIN IS FITTED WITH RUBBER O-RINGS BETWEEN ITS SIDE PLATES IN ORDER TO RETAIN THE LUBRICATING GREASE. PROCEED WITH THE UTMOST CAUTION WHEN ADJUSTING, LUBRICATING, WASHING OR REPLACING THE CHAIN.**

**COMMERCIALY AVAILABLE CHAIN LUBRICANTS MAY CONTAIN SUBSTANCES THAT DAMAGE THE RUBBER O-RINGS FITTED ON THE CHAIN.**

**DO NOT USE THE VEHICLE IMMEDIATELY AFTER LUBRICATING THE CHAIN SINCE THE LUBRICANT WOULD BE SPRAYED OUT AND CONTAMINATE THE SURROUNDING AREA.**



# SHIVER 900



**Chap. 05**  
**Technical data**

## **WEIGHT AND DIMENSIONS**

Max. length	2130 mm (83.86 in)
Max. width	810 mm (31.89 in)
Max height (at handlebar)	1110 mm (43.70 in)
Wheelbase	1465 mm (57.68 in)
Kerb weight	218 Kg (481 lb)
Weight fully loaded	435 kg (959 lb)

## **ENGINE**

Model	M55CM
Type	Four-stroke longitudinal 90° V twin-cylinder with 4 valves per cylinder, 2 cam shafts at the big end.
Cylinder number	2
Total engine capacity	896.1 cm <sup>3</sup> (54.68 cu in)
Bore / stroke	92 x 67.4 mm (3.62 x 2.65 in)



Compression ratio	11.5: 1
Start-up	Electric
Engine idle speed	1450 +/- 100 rpm
Rpm of the engine at full power	8750 +/- 100 rpm
Clutch	Multi plate wet clutch with mechanical control lever on left side of the handlebar.
Lubrication	Wet crankcase. Pressure-fed, controlled by trochoidal pump
Air filter	With dry filter cartridge
Cooling	Liquid

### **GEARBOX**

Type	Mechanical, 6 speeds with foot lever on the left hand side of the engine
------	--

### **CAPACITY**

Fuel (reserve included)	14.5 l (3.19 UK gal; 3.83 US gal)
-------------------------	-----------------------------------

Fuel reserve	3 l (0.66 UK gal; 0.79 US gal)
Engine oil	3.0 l (without oil filter change) (0.66 UK gal; 0.79 US gal) 3.2 l (with oil filter change) (0.70 UK gal; 0.85 US gal)
Coolant	1.8 l (0.40 UK gal; 0.48 US gal)
Seats	2
Maximum weight limit	215 kg (474 lb) (rider + passenger + luggage)

### **DRIVE RATIOS**

Drive ratio	Primary gear 40/69
Drive ratio, 1st gear	14/36 (secondary)
Drive ratio, 2nd gear	17/32 (secondary)
Drive ratio, 3rd gear	20/30 (secondary)
Drive ratio, 4th gear	22/28 (secondary)
Drive ratio, 5th gear	23/26 (secondary)
Drive ratio, 6th gear	24/25 (secondary)
Final drive ratio	16/44

**DRIVE CHAIN**

Type	Endless (without chain hammerlocks) and with sealed links. No. of links 108
Model	525 ZRPK

**FUEL SUPPLY SYSTEM**

Type	Electronic injection (Multipoint)
Throttle valve diameter	Diam. 52 mm (2.05 in)
Fuel	Unleaded petrol max E10 (95 RON).

**FRAME**

Type	Die-cast aluminium plates and high-yield strength steel frame.
Steering inclination angle (with extended suspensions)	26°
Trail	114 mm (4.49 in)

## **SUSPENSIONS**

Front	Telescopic upside-down hydraulic fork, stems diam 41 mm (1.61 in)
Travel	127 mm (5.00 in)
Rear	Swingarm and adjustable hydraulic monoshock
Travel	43 +/- 1 mm (1.69 +/- 0.039 in)

## **BRAKES**

Front	Double floating disc - Ø 320 mm (12.60 in), radially-mounted calliper with 2 Ø 27 mm (1.06 in) pistons; 2 diam. 32.03 mm (1.26 in) and 4 pads
Rear	Disc brake - diam. 240 mm (9.45 in), single piston calliper - diam. 35 mm (1.38 in)

## **WHEELS**

Type	In light alloy with extractable pin
Front	3.50 x 17"

Rear	6.00 x 17"
------	------------

### **TYRES**

Front	120/70 ZR17" (58W)
-------	--------------------

Inflation pressure	1 passenger: 2.3 bar (230 kPa) (33.36 PSI)
	2 passengers: 2.5 bar (250 kPa) (36.26 PSI)

Rear	180/55 ZR17" (73W)
------	--------------------

Inflation pressure	1 passenger: 2.5 bar (250 kPa) (36.26 PSI)
	2 passengers: 2.8 bar (280 kPa) (40.61 PSI)

### **SPARK PLUGS**

<b>BRAND</b>	<b>TYPE</b>	<b>RESISTANCE</b>	<b>ELECTRODE GAP</b>
NGK-R	CR8EKB	5 kOhm	0.6 - 0.7 mm (0.024 - 0.028 in)
(*) NGK-R	CR7EKB	5 kOhm	0.6 - 0.7 mm (0.024 - 0.028 in)

<b>BRAND</b>	<b>TYPE</b>	<b>RESISTANCE</b>	<b>ELECTRODE GAP</b>
(*) NGK IR	MR8BI-8	7.5 KOhm (MAX) / 3KOhm (MIN)	0.8 mm (0.031 in)

### Data

(\*) Alternative solution

## **ELECTRICAL SYSTEM**

Battery	12 V - 10 Ah YTX 12 - BS Alternative solution: 12 V - 12 Ah YTX 14 - BS
Main fuses	30 A, 5 A
Secondary fuses	7,5 A (2), 10 A, 15 A (3)
ABS fuses	20 A
Alternator (permanent magnet)	13.5 V - 450 W at 6000 rpm
Ignition	Electronic, inductive, high efficiency ignition, integrated with the injection system, with variable advance and separate H.V. coil.
Ignition advance	Three-dimensional map managed by control unit.

**BULBS**

Low beam light	12 V - 55 W H7
High beam light	12 V - 55 W H7
Front DRL	12V- 5W x 2
Turn indicators	12V - 10W
Licence plate light	12 V - 5 W
Rear daylight running light /stop light	12V- 5/21W x 2

**INDICATOR LAMPS**

ABS	LED
High beam light	LED
Fuel reserve	LED
Turn indicators	LED
Overspeed threshold/shift light	LED
Immobilizer	LED
MI	LED
General warning	LED
Side stand	LED
ATC	LED





# SHIVER 900



## Chap. 06 Programmed maintenance



## Scheduled maintenance table (06\_01)

Adequate maintenance is fundamental to ensure long-lasting, optimum operation and performance of your vehicle.

For this reason a series of checks and maintenance services has been prepared, available for purchase separately, listed together in the chart on the following page. It is a good idea to report small performance anomalies right away to an **Authorised Service Centre**, without waiting for the next scheduled service, so they can be repaired immediately.

It is necessary to have your vehicle serviced to the prescribed intervals of time, even if you have not reached the predicted mileage. Services must be performed punctually at the correct intervals to maintain the validity of the warranty. For any additional information concerning Warranty procedures and 'Scheduled Maintenance', please consult the 'Warranty Conditions'.

### NOTE

**CARRY OUT MAINTENANCE OPERATIONS AT HALF THE INTERVALS SPECIFIED IF THE VEHICLE IS USED IN PARTICULAR RAINY OR DUSTY CONDITIONS, OFF ROAD OR FOR TRACK USE.**

I: INSPECT AND CLEAN, ADJUST, LUBRICATE OR REPLACE IF NECESSARY

C: CLEAN, R: REPLACE, A: ADJUST, L: LUBRICATE

(1) Check and clean, adjust or replace, if necessary, every 1,000 Km (621 mi)

(2) Replace every 4 years

(3) At each engine start

(4) Check every month

(5) Check at every change of the rear tyre

(6) Replace at whichever of the following occurs first: 40,000 km (24,854 mi) or 4 years

(7) Check before each trip.

**SCHEDULED MAINTENANCE TABLE**

<b>Km x 1,000 (mi x 1,000)</b>	<b>1 (0.6)</b>	<b>10 (6.2)</b>	<b>20 (12.4)</b>	<b>30 (18.6)</b>	<b>40 (24.9)</b>	<b>EVERY 12 MONTHS</b>	<b>EVERY 24 MONTHS</b>
Rear shock absorber (bearings)			I		I	I	I
Spark plug			R		R		
Drive chain (1)	I		I		I	I	I
Steering bearings and steering clearance	I		I		I	I	I
Wheel bearings - Wheels			I		I	I	I
Diagnosis by tool	I	I	I	I	I	I	I
Brake discs - Brake pads wear (7)	I		I		I	I	I
Air filter		I	R	I	R		
Engine oil filter	R		R		R	R	R
Fork			I		I	I	I
General operation of the vehicle	I		I		I	I	I
Valve clearance			A		A		
Cooling system			I		I		
Braking systems	I		I		I	I	I
Light circuit	I		I		I	I	I
Safety switches (stand, stop, clutch, extra negative stroke, gas control)	I	I	I	I	I	I	I
Clutch control fluid	I		I		I	I	R
Brake fluid	I		I		I	I	R

Km x 1,000 (mi x 1,000)	1 (0.6)	10 (6.2)	20 (12.4)	30 (18.6)	40 (24.9)	EVERY 12 MONTHS	EVERY 24 MONTHS
Coolant	I		I		I	I	R
Fork oil (6)					R		
Engine oil	R	I	R	I	R	R	R
Headlight aiming			I		I		
Fork oil seals			I				
Flexible couplings (5)			I		I		
Tyres - pressure / wear (4)	I	I	I	I	I	I	I
Bolts and nuts tightening	I		I		I		
Suspension and setting	I		I		I		
Fault indicator light on dashboard (3)							
Fuel lines (2)			I		I	I	I
Clutch wear			I		I		



06\_02

### Recommended products (06\_02)

**Piaggio Group recommends the products of its "Castrol Official Partner" for the scheduled maintenance of its vehicles.**

Use lubricants and liquids having specifications that are equivalent, or superior, to the recommended products. These indications also apply when topping up fluid levels.

**TABLE OF RECOMMENDED PRODUCTS**

<b>Product</b>	<b>Description</b>	<b>Specifications</b>
Engine oil 15W-50	Synthetic-based lubricant for four-stroke engines.	SAE 15W-50, JASO MA, MA2; API SJ; ACEA A3
Fork oil 10W	Fork oil.	SAE 10W
Brake fluid DOT 4	Synthetic brake fluid.	SAE J 1703; FMVSS 116; ISO 4925; CUNA NC 956 DOT4
Anti-freeze liquid, ready to use, colour red	Ethylene glycol antifreeze liquid with organic inhibition additives. Red, ready to use.	ASTM D 3306 - ASTM D 4656 - ASTM D 4985 - CUNA NC 956-16
Lithium-based grease	Lithium-calcium soap based grease	colour - black, contains EP (Extreme Pressure) additives, excellent water-repellent properties



# TABLE OF CONTENTS

## A

ABS: 67  
Advanced functions: 34  
Air filter: 116  
Alarms: 28

## B

Battery: 14, 119, 120  
Brake: 14, 92, 118, 132  
Brake pedal: 92

## C

Chain: 138–141  
Clutch: 14, 92, 119  
Clutch fluid: 14, 119  
Clutch lever: 92  
coolant: 13, 117  
Coolant: 13, 117

## D

Disc brake: 132  
Display: 23

## E

Engine oil: 13, 112–114  
Engine stop: 67

## F

Fork: 89, 90  
Fuel: 12  
Fuses: 122

## G

Gearbox oil: 13

## H

Headlight: 127  
Horn: 64

## I

Identification: 79  
Immobilizer: 76  
Instrument panel: 22

## M

Maintenance: 111, 153, 154  
Maintenance Table: 154  
Mirrors: 130

## O

Oil filter: 114

## R

rear-view mirrors: 130  
Recommended products:  
156

## S

Saddle: 77  
Scheduled maintenance:  
154  
Shock absorbers: 86, 88  
Spark plug: 115  
Stand: 15, 103  
Start-up: 66  
Stop switch: 67

## T

Technical data: 143  
Transmission: 138  
Turn indicators: 129  
Tyres: 114

## U

Use: 81



#### THE VALUE OF SERVICE

Due to continuous updates and technical training programmes specific to Aprilia products, only **Aprilia** Official Network mechanics know this vehicle fully and have the specific tools necessary to carry out maintenance and repair operations correctly.

The reliability of the vehicle also depends on its mechanical conditions. Checking the vehicle before riding it, performing maintenance correctly and using only **original Aprilia spare parts** are essential factors for the reliability of your vehicle!

For information on the nearest **Official Dealer and/or Service Centre** consult our website:

[www.aprilia.com](http://www.aprilia.com)

Only by requesting original Aprilia spare parts can you be of purchasing products that were developed and tested during the design and development of the vehicle itself. All Aprilia original spare parts undergo quality control procedures to guarantee reliability and durability.

The descriptions and images in this publication are given for illustrative purposes only.

While the basic features as described and illustrated in this manual remain unchanged, Piaggio & C. S.p.A. reserves the right, at any time and without being required to update this publication beforehand, to make any changes to components, parts or accessory supplies which it deems necessary to improve the product, or which are required for manufacturing or commercial reasons.

Not all versions/models shown in this publication are available in all countries. The availability of individual versions/models should be confirmed with the official Aprilia sales network.

The Aprilia trademark is the property of Piaggio & C. S.p.A.

© Copyright 2019 - Piaggio & C. S.p.A. All rights reserved. Reproduction of this publication in whole or in part is prohibited.

Piaggio & C. S.p.A. Viale Rinaldo Piaggio, 25 - 56025 PONTEDERA (PI), Italy

[www.piaggio.com](http://www.piaggio.com)