

THIS SHEET INCLUDES FITTING INSTRUCTIONS FOR THE FOLLOWING PARTS:

Secondary Alternator Cover Part No. EC-RSV4-2021-1-GBR / Secondary Clutch Cover Part No. EC-RSV4-2010-2-GBR /
Bullet Frame Race Slider Set - RACE - Part No. FS-RSV4-2010-R
Paddock Stand / Bobbin Set Part No. BA12-6-RSV4-GBR-SET



SECONDARY ALTERNATOR COVER
PART NO. EC-RSV4-2021-1-GBR

- 1 Remove the factory-fitted dust cover by removing the 3 bolts.
- 2 Remove the 2 existing bolts (bolt positions 2 & 3) and 2 studs (see Fig.1) (bolt positions 1 & 4) on the stock OE cover.
- 3 Place the Secondary Alternator Cover over the stock cover.
- 4 Assemble the 4 replacement bolts, reuse stock bolt washers, loosely in the correct position as shown. DO NOT OVERTIGHTEN.

Bolt 1
M6X30HHF - 12Nm
SPB-6

Bolt 2
M6X45HHF - 12Nm
SPB-2



Bolt 3
M6X45HHF - 12Nm
SPB-2

Bolt 4
M6X30HHF - 12Nm
SPB-6

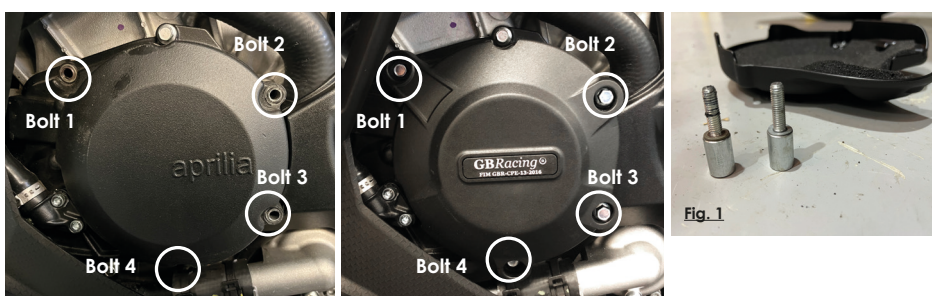

SECONDARY CLUTCH COVER
PART NO. EC-RSV4-2010-2-GBR

The **clutch** has a standard dust cover fitted to brackets. The fixing studs and brackets will need to be removed before fitting the GBRacing clutch cover. (See Fig. 2 below).

- 1 Remove 3 existing bolts from the stock Clutch cover, shown as position Bolt 1, 2 & 3. Retain stock bolt washers.
- 2 Place the Secondary Clutch Cover over the stock cover.
- 3 Assemble 3 replacement bolts, reuse stock bolt washers loosely in the correct position as shown. *The retained stock washers are fitted between the engine casing and the GBRacing cover - See Fig. 1.*
- 4 Tighten bolts to a Torque of 12Nm as per Manufacturer's recommendations. DO NOT OVERTIGHTEN.

Fig. 1

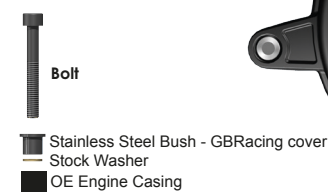

Bolt 3
M6x50 HHF - 12Nm

Bolt 1
M6x40 HHF - 12Nm

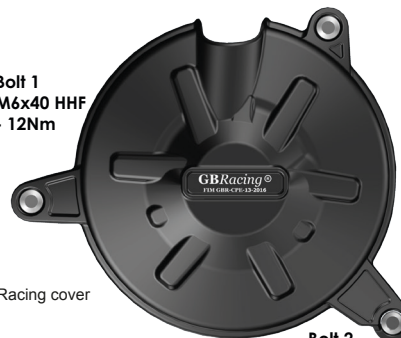

Bolt 2
M6x30 HHF - 12Nm

Fig. 2

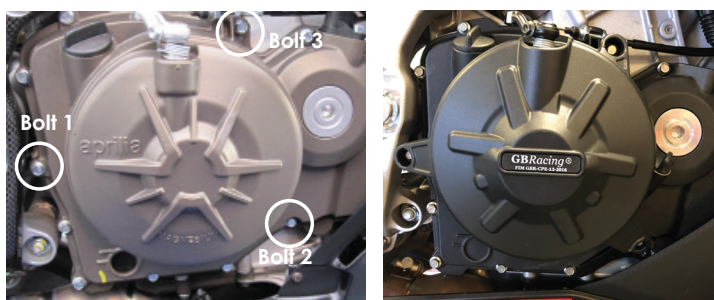

BULLET FRAME SLIDER - LEFT HAND SIDE - RACE
PART NO. FS-RSV4-2010-LHS-R

- 1 Remove upper engine mounting bolt, located through the fairing opening.
- 2 Assemble bolt through the aluminium bush into correct position.
- 3 Tighten to 25NM torque.
- 4 Slide bullet moulding onto aluminium bush.
- 5 Screw M6 bolt into front of bullet moulding hand tight.



BULLET FRAME SLIDER - RIGHT HAND SIDE - RACE
PART NO. FS-RSV4-2010-RHS-R

- 1 Remove upper engine mounting bolt, located through the fairing opening.
- 2 Assemble bolt through the aluminium bush into correct position.
- 3 Tighten to 25NM torque.
- 4 Slide bullet moulding onto aluminium bush.
- 5 Screw M6 bolt into front of bullet moulding hand tight.



PADDOCK STAND / BOBBIN SET
PART NO. BA12-6-RSV4-GBR-SET

- 1 Assemble M6 x 40mm Bolt & M6 Washer for the right hand side through the moulded bobbin.
- 2 Assemble M6 x 50mm Bolt & M6 washer for the left hand side through the moulded bobbin.
This is to allow for the refitment of the original lower chainguard.
- 3 Tighten bolts to swing arm boss, 8 N/m.

